

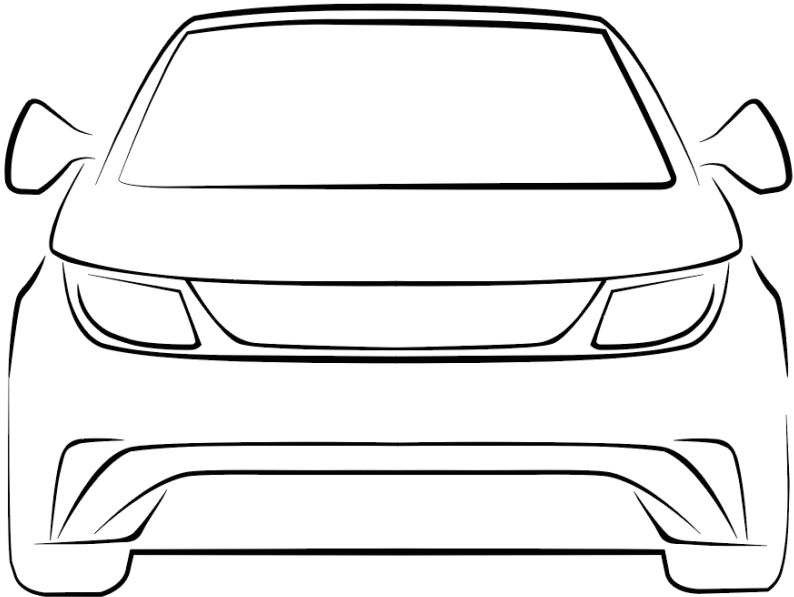

BYD DOLPHIN

OWNER'S MANUAL



Foreword

Thank you for choosing BYD. To better use and maintain the vehicle, please read this manual carefully and keep it for future reference.

Special instructions: BYD Auto Industry Co., Ltd. recommends that you choose genuine spare parts and use, maintain, and repair the vehicle in accordance with this manual. The use of non-genuine spare parts to replace or modify the vehicle will affect the performance of the entire vehicle, especially its safety and durability. Vehicle damage and performance issues caused thereby will not be covered by the warranty. In addition, vehicle modifications may also violate national laws and regulations and local government regulations.

Thank you again for choosing BYD. Your valuable comments and suggestions are welcome. To enjoy better services, please provide your accurate contact information. If there is any change to the information, contact a BYD authorised dealer or service provider in a timely manner to update the information in the system. You are also advised to pay attention to the relevant national laws and regulations and local policies, and register the vehicle as soon as possible; otherwise vehicle registration may fail.

Pay attention to the "WARNING", "CAUTION" and "REMINDER" symbols in this manual, and follow the instructions carefully to avoid injury or damage. These symbols are defined as follows:

WARNING

Items that must be observed to ensure personal safety.

CAUTION

Items that must be observed to avoid damage to the vehicle.

REMINDER

Items that must be observed to facilitate maintenance.



is a safety mark to indicate an operation that should not be performed or an event that should not happen.

The descriptions marked with the asterisk (*) in this manual are specific to some model configurations, and applicable only when the vehicle has these configurations. The

illustrations used are taken from one of the vehicle configurations. If there is any difference from the vehicle you purchased, refer to the actual vehicle.

This manual is expected to help you use the product correctly, and does not provide any description of the configuration and software version of this product. For details about the product configuration and software version, please refer to the contract (if any) related to this product, or consult the dealer who sold the product to you.

Sustainability

As a pure electric passenger vehicle, BYD DOLPHIN is an environmentally friendly product. Please visit <https://reach.bydeurope.com> for environmental protection information about the vehicle.

It is everyone's responsibility to protect the environment. Please use this vehicle properly and dispose of any waste and cleaning materials according to the corresponding local laws and regulations.

Contact Us

If you require assistance or clarification on policies or procedures, please contact the customer service center.

E-mail: Autoservice.contact@byd.com

For 24/7 roadside assistance or customer service (9:00-18:00, Monday-Saturday), call 00800-10203000.

Copyright © BYD Auto Industry Co., Ltd. All rights reserved.

No part of this document may be reproduced, copied, stored, translated, or transmitted electronically or in any other form without prior written consent and authorization of BYD Auto Industry Co., Ltd.

All rights reserved

Illustration Index

Exterior	7
Dashboard	8
Interior	9
Doors	10

Safety

Seat Belts	12
Seat Belt Overview.....	12
Using Seat Belts.....	12
Airbags	15
Airbags.....	15
Driver and Front Passenger Airbags.....	15
Front Seat Side Airbags.....	16
Side Curtain Airbags.....	17
Airbag Triggering Conditions and Precautions.....	17
Child Restraint Systems	21
Child Restraint Systems.....	21
Anti-theft System*	26
Anti-theft System*.....	26
Data Collection and Processing	27
Data Collection and Processing.....	27

Instrument Cluster

Instrument Cluster	32
Instrument Cluster View.....	32
Instrument Cluster Indicators.....	33

Controller Operation

Doors and Keys	42
Keys.....	42

Locking/Unlocking Doors.....	46
Smart Access and Start System.....	49
Child Protection Lock.....	51
Seats	51
Seat Precautions.....	51
Adjusting Front Seats.....	52
Folding Rear Seats.....	53
Head Supports.....	53
Steering Wheel	55
Steering Wheel Switches.....	55
Adjusting the Steering Wheel.....	57
Switches	58
Light Switches.....	58
Wiper Switches.....	61
Driver's Door Switches.....	62
Side Windows.....	64
Odometer Switch.....	64
Driver Assistance Switches.....	64
Passenger Airbag Switch.....	65
Emergency Call (E-Call).....	66
Hazard Warning Light Switch.....	67
Sunshade*.....	68
Interior Light Switch.....	68

Using and Driving

Charging/Discharging Instructions	72
Charging Instructions.....	72
Charging.....	76
Charge Port Anti-theft Lock.....	84
External Discharging.....	84
Battery	86
High-Voltage Battery.....	86
Low-Voltage Battery.....	88
Usage Precautions	90

Break-in Period.....	90
Trailer Towing.....	91
Driving Safety Precautions.....	91
Vehicle Use Suggestions.....	92
Carrying Luggage.....	93
Wading into Water.....	93
Fire Prevention.....	94
Saving Energy and Extending Vehicle Service Life.....	96
Starting and Driving.....	96
Starting the Vehicle.....	96
Driving.....	97
Gear Shift Controls.....	98
Electronic Parking Brake (EPB).....	99
Automatic Vehicle Hold (AVH).....	101
Driving Precautions.....	102
Driver Assistance.....	104
Adaptive Cruise Control (ACC).....	104
Intelligent Cruise Control (ICC).....	108
Predictive Collision Warning (PCW) & Automatic Emergency Braking (AEB).....	110
Front Cross Traffic Alert (FCTA) & Front Cross Traffic Braking (FCTB).....	113
Traffic Sign Recognition (TSR).....	114
Intelligent Speed Limit Control (ISLC)..	115
Intelligent High Beam Control (IHBC)..	116
Lane Departure Assist (LDA).....	117
Emergency Lane Keeping Assist (ELKA).....	119
Blind Spot Assist (BSA).....	120
Driver Attention Warning (DAW).....	122
Child Presence Detection (CPD).....	123
Tyre Pressure Monitoring.....	124
Acoustic Vehicle Alerting System (AVAS).....	125
Panoramic View System.....	126

Parking Assist System.....	127
Driving Safety Systems.....	131
Other Main Functions.....	135
Interior Rearview Mirror.....	135
Side Mirrors.....	136
Wipers.....	136
Snow Chains.....	137

In-Vehicle Devices

Infotainment System.....	140
Infotainment Touchscreen.....	140
Navigation Bar.....	141
Gestures and Responses.....	141
OTA Update.....	141
BYD Assistant.....	141
Bluetooth Call.....	142
File Management.....	142
A/C System.....	142
A/C Buttons.....	142
A/C Operation Interface.....	143
A/C Function Definitions.....	143
Usage Precautions.....	145
Vents.....	146
BYD App.....	146
BYD App.....	146
Account Registration.....	146
Vehicle Condition and Control.....	147
Individual Centre and Vehicle Management.....	147
Storage.....	147
Door Bins.....	147
Bill Box.....	147
Dashboard Central Storage Compartment.....	148
Glove Box.....	148

Centre Console Storage Compartment.....	148
Cup Holder.....	149
Glasses Case*.....	149
Seatback Pockets.....	149
Other Devices.....	149
Sun Visor.....	149
Grab Handles.....	150
USB Ports.....	150
SD Card Slot*.....	151
12V Auxiliary Power.....	151
Wireless Phone Charger*.....	151
Cargo Cover.....	153
Hook.....	153
Window Breaker.....	154

Maintenance

Maintenance Information.....	156
Maintenance Cycle and Items.....	156
Regular Maintenance.....	158
Regular Maintenance.....	158
Vehicle Corrosion Prevention.....	159
Paint Maintenance Tips.....	159
Exterior Cleaning.....	160
Interior Cleaning.....	161
Self-Maintenance.....	163
Self-Maintenance.....	163
Canopy Maintenance*.....	164
Vehicle Storage.....	165
Bonnet.....	165
Cooling System.....	166
Braking System.....	167
Washer.....	167
A/C System.....	167

Wiper Blades.....	168
Tyres.....	169
Fuses.....	171

When Faults Occur

When Faults Occur.....	174
Reflective Vest.....	174
If Smart Key Battery Is Exhausted.....	174
Emergency Shutdown System.....	174
Vehicle Fire Rescue.....	175
Battery Leakage Rescue.....	175
If the Vehicle Needs Towing.....	176
If a Tyre Goes Flat.....	177

Specifications

Vehicle Data.....	182
Vehicle Data.....	182
Information.....	187
Vehicle Identification.....	187
Warning Labels.....	188
Transponder Mounting Position.....	189
Declarations of Conformity.....	190
Declarations of Conformity.....	190
Radio Frequency Identification.....	190

Abbreviations

Abbreviations.....	197
---------------------------	------------

Illustration Index

Exterior

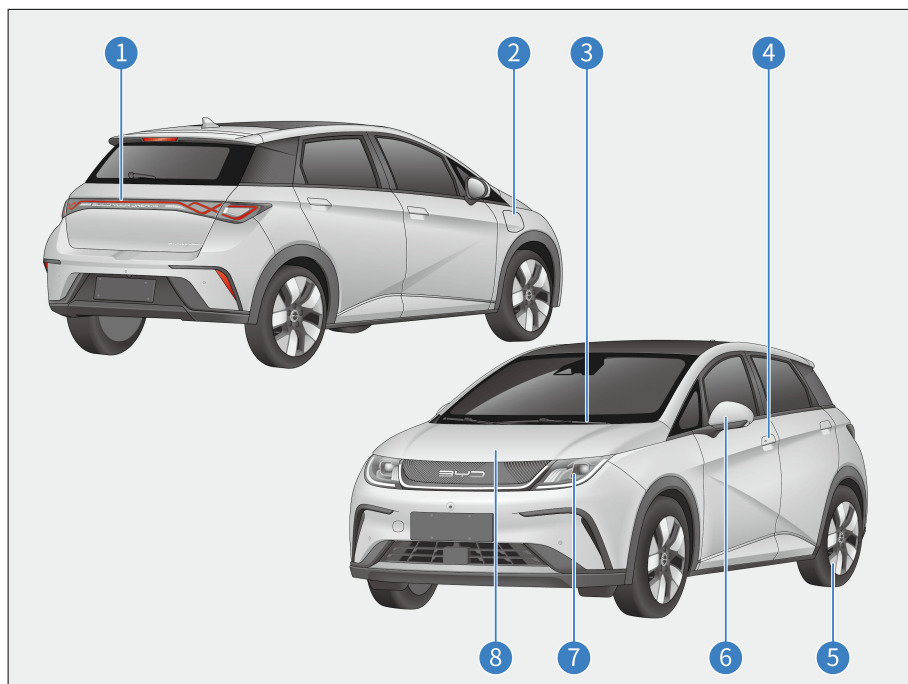

1 Boot Lid **P48**

2 Charge Port Door **P84**

Using Mode 2 Charging Cable **P76**

Using AC Charging Piles **P79**

Using DC Charging Piles **P80**

3 Wiper **P61**

4 Doors **P46**

5 Tyre **P169**

6 Power Side Mirror **P136**

7 Combination Lights **P58**

8 Bonnet **P165**

Cooling System **P166**

Washer **P167**

Brake Fluid **P167**

Dashboard

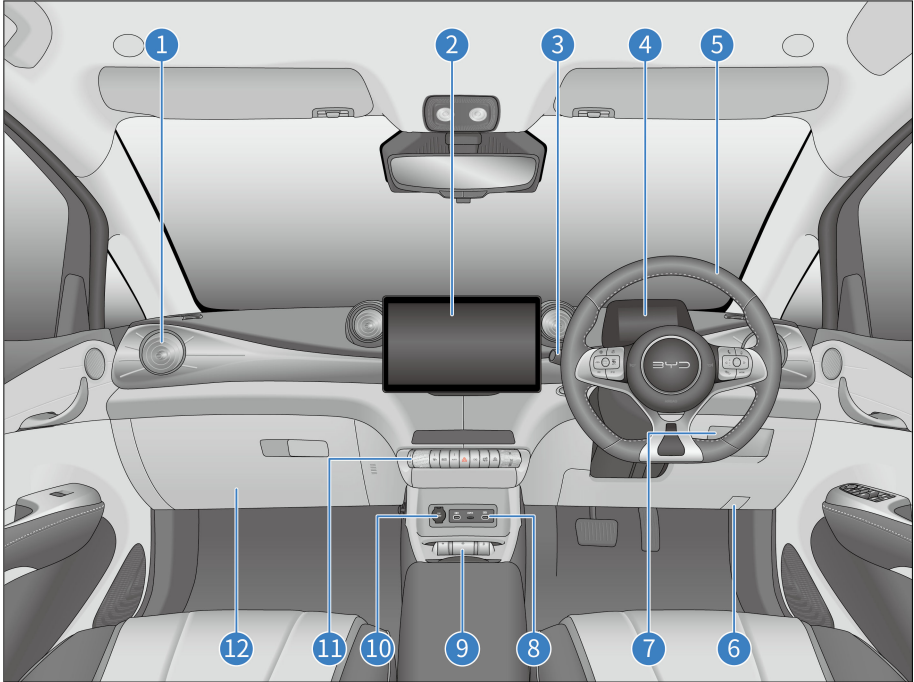

- | | | | |
|---|--------------------------------------|----|--|
| 1 | Vents P146 | 9 | Electronic Parking Brake (EPB) Switch P99 |
| 2 | Infotainment Touchscreen P140 | | Automatic Vehicle Hold (AVH) Switch P101 |
| 3 | Light Switches P58 | | ESC OFF Switch P131 |
| 4 | Instrument Cluster P32 | 10 | 12V Power Outlet P151 |
| 5 | Steering Wheel P57 | 11 | Driver Assistance Switches P64 |
| | Steering Wheel Switches P55 | | Gear Shift Controls P98 |
| 6 | Bonnet Handle P165 | | A/C ON/OFF Button P142 |
| 7 | Bill Box P147 | 12 | Glove Box P148 |
| 8 | Charge Port P150 | | |

Interior

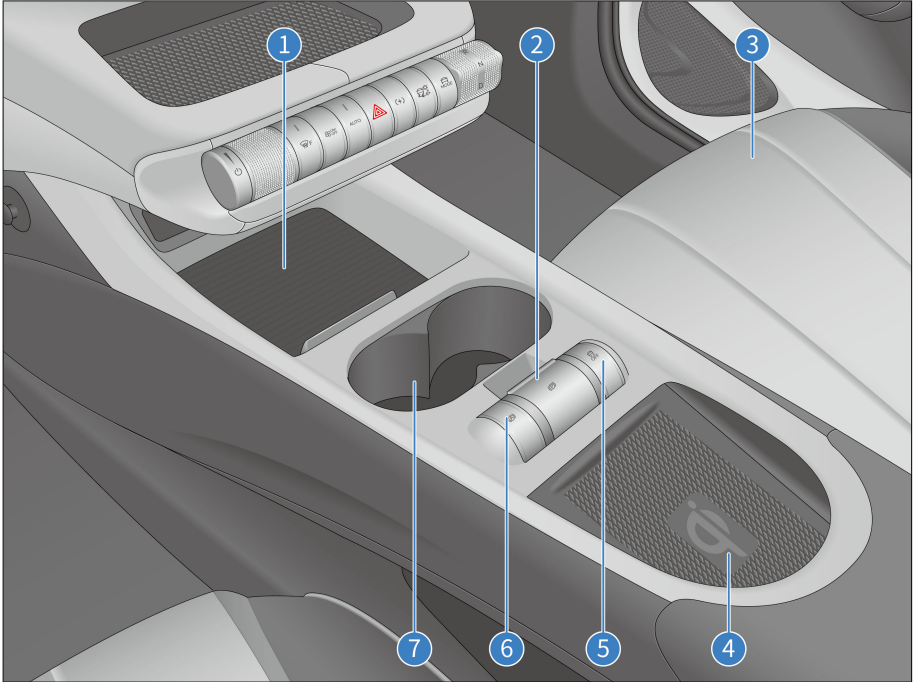

- 1 Centre Console Storage Compartment **P148**
- 2 Electronic Parking Brake (EPB) Switch **P99**
- 3 Seat **P51**
- 4 Wireless Phone Charger* **P151**
- 5 ESC OFF Switch **P131**
- 6 Automatic Vehicle Hold (AVH) Switch **P101**
- 7 Cup Holder **P149**

Doors

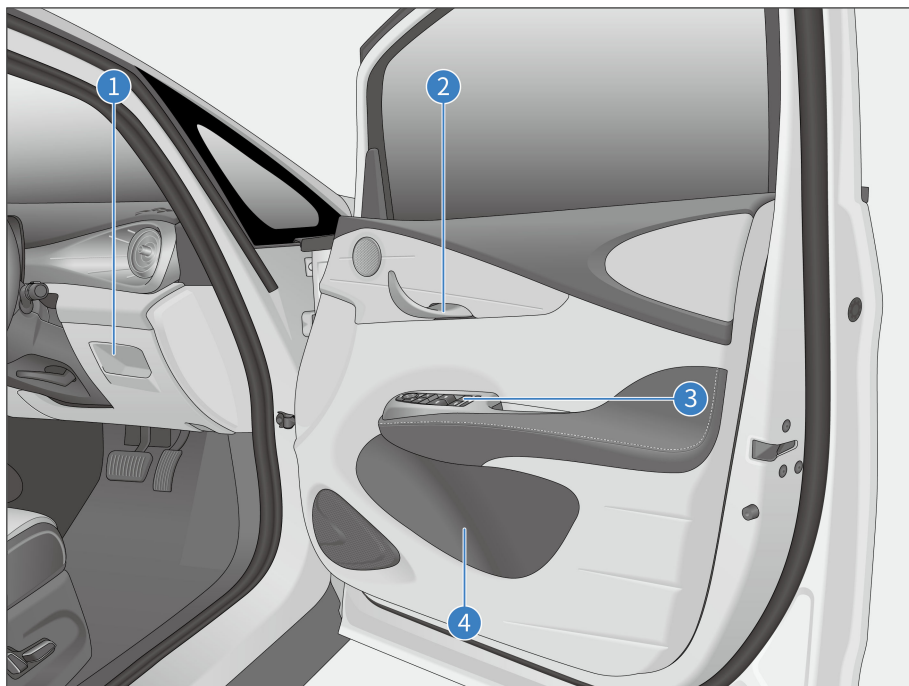

1 Bill Box **P147**

2 Interior Door Handle **P46**

3 Driver's Door Switches **P62**

Window Lock Switch **P63**

Central Locking **P64**

Side Mirror Switches **P136**

4 Door Bin **P147**

01

SAFETY

Seat Belts.....	12
Airbags.....	15
Child Restraint Systems.....	21
Anti-theft System*	26
Data Collection and Processing.....	27

Seat Belts

Seat Belt Overview

Studies have shown that proper use of seat belts can significantly reduce casualties in emergency braking, sudden steering or collisions. Please read the following information carefully and observe it strictly.

CAUTION

- Before driving, make sure all occupants are properly buckled up to prevent serious injury or death in emergency braking or in a collision.
- The seat belts are designed primarily for adults and are not intended for children. Make sure to choose an appropriate child restraint system according to your child's age and size (see **P23**).
- If a seat belt is damaged or malfunctions, immediately contact a BYD authorised dealer or service provider for confirmation and handling. Until then, do not use the corresponding seat.

- BYD has highly emphasized that all occupants should always fasten their seat belts while in the vehicle to prevent serious injury or death.
- It is recommended that children be seated in rear seats and always use seat belts and suitable child restraints. In emergency braking or collision, unprotected children may be seriously injured and their lives may be endangered. Likewise, do not allow children to be carried on someone's lap. This will render the children not adequately protected.

Emergency Locking Retractor Function

- When the driver turns sharply or brakes suddenly, when there is a collision, or when the occupant leans forward too quickly, the seat belt automatically locks to effectively restrain and protect the occupant.
- When the vehicle travels smoothly, seat belts are pulled out and retracted as the occupants move slowly and smoothly, allowing the occupants to move freely.
- If the seat belt locks due to sudden retraction, pull on the seat belt webbing to create retractable slack in order to pull out the seat belt.

Pretensioner and Force Limiter Function

When a severe front collision occurs and the triggering conditions of the pretensioner are met, the pretensioner quickly retracts part of the seat belt and locks it to improve the protection of the occupant. The force limiter limits the seat-belt restraint force to the occupant's body to a certain extent so as to avoid injury to the occupant due to an excessive restraint force.

Using Seat Belts

1. Adjust the seat position and seatback angle (see **P52**).
2. Adjust the position of the three-point seat belt.
 - Keep the correct sitting posture and pull out the shoulder belt diagonally across the entire shoulder without contacting the neck or falling from the shoulder. Position the lap belt as low as possible around the hip.

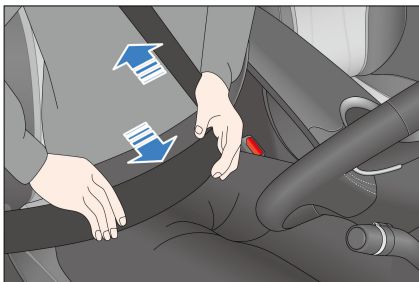

! CAUTION

- The shoulder belt should cross the centre of the shoulder. The seat belt should be far from the neck and not liable to slip from the shoulder; otherwise, it cannot function well in the event of emergency braking or accident and may even cause severe injury.
- The lap belt should be positioned as low as possible across the hip to prevent any injury caused by pressing against the abdomen in case of an accident.
- The seat belt should be fitted tight to the body for better protection.

3. Insert the latch into the buckle until it clicks, and then pull it back to make sure it is firmly locked. Do not fasten the belt with any part of the strap twisted.



4. Unlock the seat belt.

- Press the red unlock button on the buckle. The latch plate pops out, and

the seat belt automatically retracts. If the seat belt does not retract smoothly and automatically, pull it out and check whether it is twisted.

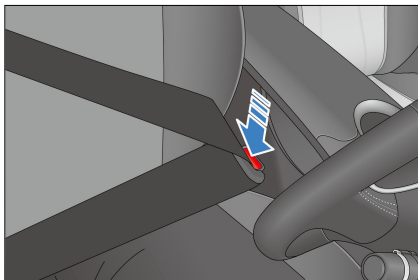

! CAUTION

- One seat belt is for one occupant only. Do not share a seat belt with another occupant, not even with a child.
- Avoid travelling with the seatback leaning too far back. The seat belt protection performs best when the seatback is upright.
- Make sure that no seat belt or its spring bolt/buckle becomes pressed by the door; otherwise the seat belt may be damaged.
- Check the seat belts regularly for cuts, wear, looseness, and other abnormalities. If any problem is found, contact a BYD authorised dealer or service provider for confirmation and handling. Until then, do not use the corresponding seat.
- Do not remove, disassemble or modify the seat belts without permission.
- After an accident, have the seat belts checked at a BYD authorised dealer or service provider. The associated seat belts and pyrotechnic lap

CAUTION

pretensioners* must be replaced if the pretensioner function has been activated.

- In the event of a severe accident, regardless of whether the seat belt has an apparent damage, replace it together with the seat assembly, and thoroughly check the airbag system.
- Pregnant women need to fasten the seat belts properly and position the lapbelt as low as possible around the hips to avoid serious injury caused by the intense lap belt forces against the abdomen in an accident.
- Do not insert foreign objects such as coins and clips into the buckle as they prevent proper connection between the latch and buckle.
- Use an approved model whenever you replace the seat belt.

REMINDER

- For normal functioning of the rear seat belt, ensure that its latch is inserted into the corresponding buckle during use. The driver should remind occupants to wear seat belts properly.
- The driver should ensure that all occupants are wearing seat belts before driving the vehicle.

Seat Belt Reminders

If any occupant has not buckled up after the vehicle is started, visual and audible alarms go off and continue until the corresponding seat belt is properly fastened.

- Seat belt reminder

If any occupant has not buckled up after the vehicle is started, visual and audible alarms go off and continue until the corresponding seat belt is properly fastened.

- Display of unfastened belt's seat

The indicator for the seat with unfastened seat belt lights up.

- Seat belt reminder for front passenger

If the driver or front passenger has not buckled up after the ignition is switched on, the seat belt reminder indicator and the indicator associated with the corresponding seat light up. If the seat belt remains unfastened while driving, in addition to the reminder indicator, an audible alarm is given to alert the driver and the occupant.

- Seat belt reminder for rear passengers

With the ignition on, if any rear passenger does not buckle up, the seat belt reminder indicator and the indicator associated with the corresponding seat light up. While the vehicle is in motion, when only rear seats are loaded with occupant(s), who have not buckled up, only the seat belt reminder indicator is on and no audible alarm is given.

- When the driver, the front passenger, and rear passengers have buckled up, the seat belt reminder indicator and all indicators displayed for the corresponding seats turn off.

REMINDER

- In the event of abnormality or function failure, contact a BYD authorised dealer or service provider. Do not use the corresponding seat until the functions return to normal.

! REMINDER

- When driving, make sure all occupants have their seat belts properly fastened to prevent serious injury or death in emergency braking or in a collision.

Airbags

Airbags

- The airbag system is a part of auxiliary restraint system and also a supplement to seat belts. When the vehicle is involved in a serious collision and the airbag system meets its deployment conditions, relevant airbags will rapidly deploy and, along with seat belts, provide additional protection for heads and chests of the occupants, to reduce likelihood of personal injury or even death.
- Airbags are divided into front and side types, according to the type of collision. The front airbags include a driver airbag and a front passenger airbag, while side airbags include side airbags, the far side airbag, and curtain airbags.
- As an integral part of the vehicle's passive safety protection system, the airbag system does not replace seat belts and must be used in combination with seat belts to maximise protection.

! REMINDER

- Occupants must sit in a proper position to maximise the protection provided by seat belts and the airbag system.

! REMINDER

- Do not disassemble or assemble airbag components without authorisation.
- If the seatbacks get wet from rain or splashes, the side airbag system may not work properly.
- Do not use seat covers, as they restrict airbag deployment on the corresponding side in an accident.
- Do not place anything between the side airbag and the occupant.
- Do not apply excessive force to the side of seats equipped with side airbags.
- After a collision, even if the airbag did not deploy, and the pretensioner did not lock the seat belt, to ensure the normal operation of the airbag system, contact a BYD authorised dealer or service provider for inspection as soon as possible.
- If the vehicle is ingressed with water (wet carpet or vehicle submerged in water) or damaged by water, do not start the vehicle and the low-voltage battery needs to be disconnected. Otherwise, the airbags may deploy, resulting in serious injury or death.

Driver and Front Passenger Airbags

This vehicle is equipped with driver and front passenger airbags. When the airbag system Electronic Control Unit (ECU) detects a moderate to severe front impact, and the triggering conditions are met, the airbags deploy.

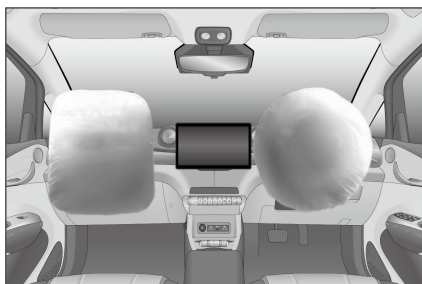

Front airbag deployment

- In moderate to severe frontal crashes, a sensor detects a sharp deceleration and sends a signal to the ECU to trigger the front airbags.
- When there is a frontal crash, the seat belt secures the occupant's lower body and torso in place. The airbag cushions and protects the occupant's head and chest.
- When the severity of the impact does not reach the airbag deployment threshold, seat belts provide the main protection while airbags assist little to the protection.
- The front airbag deflates immediately after inflation, without affecting the driver's vision and ability to operate the steering wheel or other controls.
- The airbag deploys within a thousandth of a second.
- A loud noise will be heard when the airbag deploys. It will not cause injury, but it may cause tinnitus or temporary deafness.
- A cloud of dust from the airbag surface may come off when the airbag deploys. Although such powder is non-toxic, individuals with respiratory problem might experience some temporary discomfort.
- The front passenger airbag is controlled by the passenger airbag switch. See **P65** for details.

WARNING

- No accessories, such as telephone holders, cups, ashtrays, may be installed on airbag covers or within their action range. Otherwise, airbag deployment will increase the risk of injury in an accident.

Front Seat Side Airbags

The vehicle is equipped with side airbags for the left and right front seats (installed in the outer edges of the front-row seatbacks and marked with "AIRBAG", as shown in the illustration).

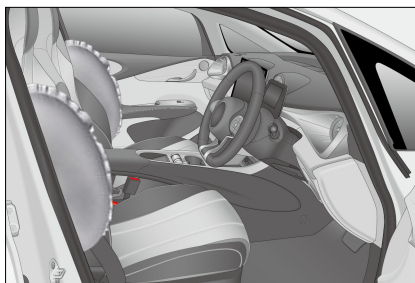

- When a moderate to severe side impact is detected during vehicle travel and the triggering conditions are met, the side airbag deploys to protect the occupant's chest.
- Generally, only the airbag on the impacted side deploys in the event of a side impact.
- If the impact occurs on the passenger side, the airbag on the passenger side deploys even if there is no passenger in the seat.
- For optimal side airbag protection, occupants must have their seat belts fastened and sit upright against the seatback.

Front far side airbag:

- The vehicle you purchased is equipped with a front far side airbag (installed in the inner edge of the driver's seatback and marked with "AIRBAG", as shown in the illustration).

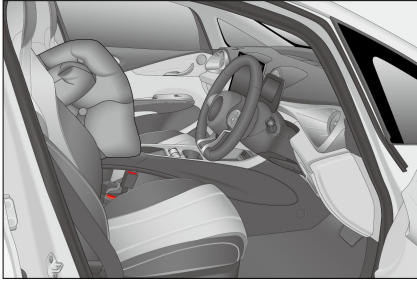

- When a moderate to severe front or side impact is detected during vehicle travel and the triggering conditions are met, the far side airbag deploys to protect the heads and shoulders of the driver and the front passenger.
- If the impact occurs on the front passenger side, the far side airbag deploys even if there is no passenger in the seat.
- For optimum protection from the driver far side airbag, the occupant must have the seat belt fastened and sit in an upright position.

In a vehicle equipped with seat side airbags:

- Prevent the seatbacks from getting wet. If they get wet from rain or splashes, the side airbag system may not work properly.
- Do not cover or replace seatback covers on your own. Unsuitable seatback covers may prevent airbag deployment in a collision.

Side Curtain Airbags

- The vehicle is equipped with curtain airbags for the left and right front seats

(installed at the junction of the body side trim and the ceiling and marked with "AIRBAG" on the A-pillar, B-pillar, and C-pillar trims, as shown in the illustration).



- When a moderate to severe side impact is detected during vehicle travel and the triggering conditions are met, the side curtain airbag deploys to protect the head of the occupant on the side of collision.

! REMINDER

- Generally, only the airbag on the impacted side deploys in the event of a side impact.
- For optimum curtain airbag protection, the occupant must have their seat belt fastened and sit in an upright position.

Airbag Triggering Conditions and Precautions

Airbag Triggering Conditions

- Airbag triggering conditions: In the event of a vehicle collision, whether an airbag will be triggered is decided by factors such as the amount of collision energy, accident type, collision angle, obstacles, and vehicle speed. The airbag system may be triggered in special collisions.

- The airbag system does not always work in any accident, and generally it will not be triggered in the event of a minor frontal collision, rear collision or rollover. In this case, the driver and passengers are protected by their properly fastened seat belts.
- Determinants of airbag system triggering: Decision is made by comparing the deceleration curve, generated in the collision and obtained by the ECU, and the set value. If signals, such as the deceleration curve generated and measured in the collision, are lower than the respective reference values preset in the ECU, the airbag system will not be triggered even if the vehicle may have been seriously deformed in the accident.
- The ECU of the BYD airbag system has been set up with considerations of common misuse and road conditions. However, due to the increasing changes in causes and forms of vehicle collisions, for your safety, please strictly follow this user manual, use the vehicle correctly, and avoid its misuse. Otherwise, there is no guarantee that the airbags will achieve their expected effect.

Cases When Airbags May Be Deployed

- ① The vehicle's nose hits the ground when crossing a deep groove.
- ② The vehicle hits a bump or kerbstone.
- ③ The vehicle's nose hits the ground when going down a steep slope.
- ④ One side of the vehicle is hit by another vehicle.

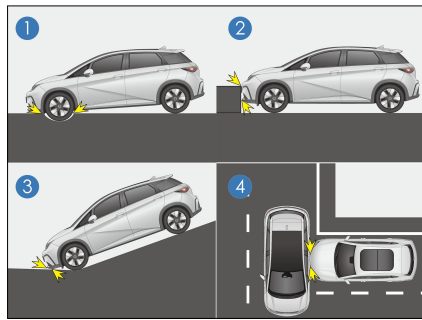

Cases When Airbags May Not Be Deployed

- ① The vehicle hits a concrete column, tree, or other slim objects.
- ② The vehicle goes under a truck or another large vehicle.
- ③ The vehicle tail is hit by another vehicle.
- ④ The vehicle rolls over.

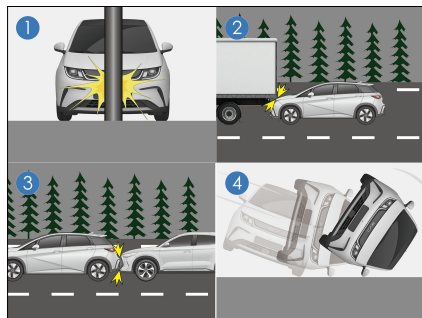

- ⑤ The vehicle hits a wall or a vehicle at a side other than the front side.
- ⑥ Parts other than the passenger compartment receive side impact.
- ⑦ The lateral side of the vehicle is hit diagonally.
- ⑧ The lateral side of the vehicle hits a columnar object.

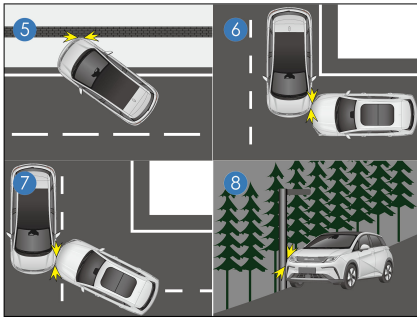

WARNING

- Airbags are designed for specific models. Any change to suspension, tyre size, bumpers, chassis and factory-equipped devices may adversely affect the airbag system. Users must not use any parts of the airbag system on other car models; doing so may lead to failure of the airbag system.
- Drivers should maintain a distance of at least 10 in (25 cm) between their chest and the steering wheel, in order for the system to provide the most effective driver protection.
- Fasten your seat belt and sit properly while the vehicle is in motion. If the seat belt is not fastened, if the occupant is leaning forward or sitting improperly, airbag deployment can increase the risk of injury.
- Do not paste stickers, cover or decorate the hub cover of the steering wheel, the right side surface of the dashboard or the surface of A, B, and C-pillar trims. Clean these surfaces with a dry or damp cloth, without applying too much pressure.

WARNING

- A child is not to be seated in the front passenger seat, nor are they to ride sitting on a front passenger's lap, to prevent serious injury or even casualty caused by airbag deployment.
- Side airbags and side curtain airbags deploy quickly with high impact forces. Occupants must not lean against the doors of vehicles equipped with these airbags while these vehicles are in motion. Failure to do so could result in serious injury or even death.
- Do not place any other accessories or items within the action range of side curtain airbags, including the windscreen, side door glass, A-pillar trim, ceiling, B-pillar trim, C-pillar trim and auxiliary handles. When the side curtain airbag deploys, the accessories or items will be thrown by the impact force from the side air curtain airbag, or the side curtain airbag may not deploy normally, resulting in serious injury or even death.
- When transferring car ownership, make sure to pass on all of the vehicle's documents and keep the new ownership informed of airbag conditions.
- Do not modify or replace seats or trims of the seats with side airbags. These changes may prevent normal deployment of side airbags, and thereby cause airbag system failure or unintended deployment of side airbags, resulting in serious injury or death.

! WARNING

- Do not disassemble or repair the A-pillar trim, ceiling, B-pillar trim or C-pillar trim, which contain side curtain airbags. These changes can cause failure of the airbag system or accidental deployment of curtain airbags, which may cause serious injury or even death.
- Do not change any component of the airbag system, including any corresponding label. It is recommended that any operation done to the airbags be performed by a BYD authorised dealer or service provider.
- Airbags can only provide one-time accident protection. Once the airbag is triggered or damaged, the airbag system must be replaced.
- Follow safety regulations and procedures related to the scrapping of parts of the vehicle or its airbag system.
- The airbag system has strong anti-interference and anti-disturbance resistance to electromagnetic fields around it. However, to avoid accidents, do not use the vehicle in an electromagnetic environment that violates national regulations.
- The airbag system of this vehicle is designed with full consideration of domestic common misuses and road conditions. However, in order to avoid accidents, do not have the bottom of the vehicle impacted or drive roughly in harsh road conditions.
- This vehicle's airbag system has been fully verified to seamlessly

! WARNING

match the vehicle's original wiring harness system. Any wiring harness modification or alteration may cause the airbags to deploy mistakenly under normal conditions or fail to deploy in the event of a collision.

It is recommended that you contact a BYD authorised dealer or service provider immediately if any of the following situations occurs.

- Any airbag has deployed.
- The airbag fault warning light  comes on abnormally on the instrument cluster.
- There is a collision with the front of the vehicle (highlighted area shown), but the airbags do not deploy.

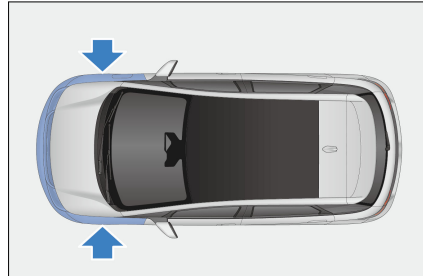

- The airbag cover (highlighted area shown) has been scratched, cracked or otherwise damaged.

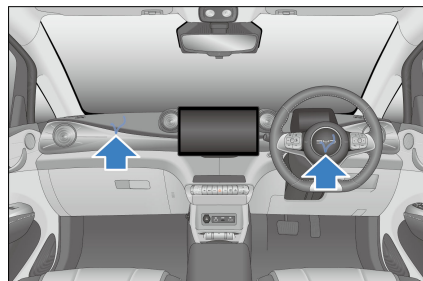

- Airbags need to be removed, disassembled, installed or repaired.
- An impact to a vehicle door (highlighted area shown) in an accident is not adequate to cause the airbag to deploy.

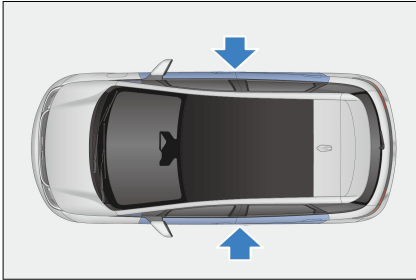

- The surface of the seat with a side airbag is scratched, cracked, or damaged similarly.
- Decorative (liner) parts at A-pillar with built-in curtain airbags, roof beam and C-pillar are scratched, cracked, or damaged similarly.

Child Restraint Systems

Child Restraint Systems

Child restraint systems provide good protection to your child in an accident. For the child's safety, please carefully read the instructions provided with the child restraint and in this manual before installing a child restraint.

WARNING

- Never carry a child on your lap in a vehicle journey.

WARNING

- An appropriate child restraint system must be used for your child.
- Please follow the instructions provided with the child restraint system and in this manual to make sure the child restraint it is properly installed in the vehicle.
- After the child restraint is dismantled from the seat, store it safely in your vehicle.
- Failure to follow the instruction provided with the child restraint and in this manual may cause injuries and even death to your child in an accident.

Children must use a suitable child restraint when travelling in the vehicle. Children should sit comfortably and safely. Make sure that the child restraint is positioned, mounted, and used correctly.

Important considerations for selecting a child restraint system

- The child restraint system is the correct type and size for the child.
- The child restraint system is the correct type and size for the seating position.
- The child restraint system must be homologated by ECE R44/R129.

Passenger Airbag Switch

- The switch is located on the passenger side of the dashboard and is accessible when the passenger's door is open.
- See **P65** for details.

WARNING

- Never use a rear-facing child restraint on the front passenger

! WARNING

seat if the passenger airbag is activated.

Child Restraint System Anchorages

Front passenger seat

- The front passenger seat is equipped with ISOFIX/i-Size anchorages. The anchorage locations are identified by a marking (see illustration) located on the seatback, directly above the associated anchorages.

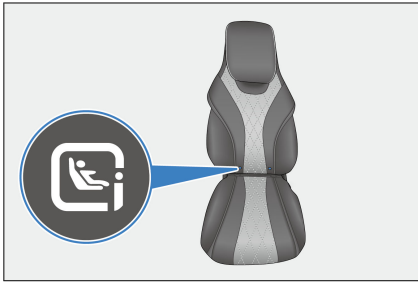

- The front passenger seat is equipped with tether strap anchorages on the back.



! WARNING

- Where applicable to use a top tether strap with the child restraint system, ensure the strap is routed through the hole in

! WARNING

the head support before attaching and tensioning the strap to the anchorage point at the base of the seat.

Rear outboard seating positions

- The rear outboard seats are equipped with ISOFIX/i-Size anchorages.



- The anchorage locations are identified by a marking (see illustration) located on the seatback, directly above the associated anchorages.



! CAUTION

- The anchorages are located in the gap between the seat cushion and the seatback.
- The rear seats are equipped with tether strap anchorages on the back.

- The use of top tether anchorage point with a belted child restraint is allowed in specific markets only.

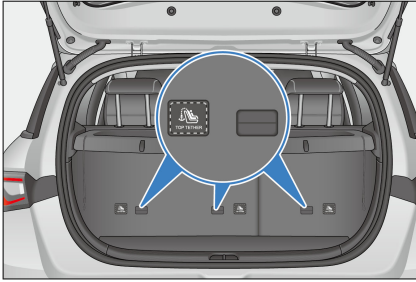

WARNING

- When the child restraint installed on a rear outboard seat is with top tether, remove the cargo cover to have access to the top tether anchorage.
- Never allow a child to climb onto the cargo cover, otherwise, damage to the cargo cover, or even injury/death to the child, can happen.
- Child restraint anchorages are designed to withstand only those loads imposed by correctly fitted child restraints. Under no circumstances are they to be used for adult seat belts, harnesses, or for attaching other items or equipment to the vehicle.

Installing Child Restraint Systems

Always follow the instructions below when using a child restraint on the front passenger seat:

- Never use a rearward-facing child restraint on the front passenger seat if the passenger airbag is activated. The airbag must be activated immediately after the rearward-facing

child restraint system is dismantled from the front passenger seat.

- If needed, adjust the front passenger seat backwards so that there is no contact between the child and vehicle interior.
- If needed, the front passenger seatback can be adjusted so that it has secure contact with the child restraint system.
- For child restraint systems with the guide fitting of belt attached to the child seat headrest, ensure that the guide fitting is positioned forward or in line with the seat belt upper anchorage on the vehicle's B-pillar.
- When a forward-facing child restraint system is used on the front passenger seat, ensure that the seat is positioned fully rearward away from the active airbag.
- Ensure that the seat belt passes through the guide fitting without kinking and is not bent over the edge of the guide fitting.

Always follow the instructions below when using a child restraint on a rear seat:

- When the child restraint system is installed on any rear seats, front seats can be adjusted forward to ensure that the child is not in contact with the front seats. Meanwhile, the front seatback angle can also be adjusted to have more space.
- The head support can be adjusted or even removed to ensure that the vehicle seatback can safely support the child restraint system.
- When a child restraint is without seatback, never remove the head support from the vehicle and adjust it to locking position.

- When the top tether is used on a rear outboard seat, route it at the outside of each head support rod.
- When the child restraint installed on a rear outboard seat is with top tether, remove the cargo cover to have access

to the top tether anchorage. Store the cover safely in your vehicle.

- For more installation instructions, please read the instructions provided with your child restraint system.

Type	Seating Position					
	1	2		3 b)	4 b)	5 b)
		Front Passenger Airbag Activated a)	Front Passenger Airbag Deactivate d a)			
Seating position suitable for universal belted (Yes/No)	×	Yes Forward-facing only	Yes	Yes	Yes	Yes
i-Size seating position (Yes/No)	×	Yes Forward-facing only	Yes	Yes	No	Yes
Seating position suitable for lateral fixture (L1/L2/No)	×	No	No	No	No	No
Largest suitable rearward-facing fixture (R1/R2X/R2/R3/No)	×	No	R1/R2X/R2/R3	R1/R2X/R2/R3	No	R1/R2X/R2/R3
Largest suitable forward-	×	F2X/F2/F3	F2X/F2/F3	F2X/F2/F3	No	F2X/F2/F3

Type	Seating Position					
	1	2		3 ^{b)}	4 ^{b)}	5 ^{b)}
		Front Passenger Airbag Activated ^{a)}	Front Passenger Airbag Deactivate ^{d a)}			
facing fixture (F2X/F2/F3/No)						
Largest suitable booster fixture (B2/B3/No)	×	B2/B3	B2/B3	B2/B3	B2/B3	B2/B3
<p>^{a)} If needed, the seat can be adjusted in forward or backward, and the seatback angle can be adjusted.</p> <p>^{b)} If needed, the headrest can be adjusted or even removed. The front seats can be adjusted to ensure the child is not in contact with them.</p>						
<p>×: seat position not suitable for installing a child restraint of this weight group</p>			<p>Grouping of child stature according to ECE R129 standard</p>			
<p>• Recommended child restraint systems:</p>						
Child Stature (cm)	Manufacturer	Child Restraint Systems		Comment		
16-33 in (40-83 cm)	Maxi-Cosi	Pebble 360		Belted		
30-41 in (76-105 cm)	Britax Römer	Trifix 2 i-Size		ISOFIX and belted		
39-59 in (100-150 cm)	Britax Römer	Kidfix i-Size ^{a)}		ISOFIX and belted		
<p>^{a)}: Be sure to attach the seat belt through SecureGuard and XP-PAD.</p>						

Grouping of child weight according to ECE R44 standard

Child Weight	Manufacturer	Child Restraint Systems	Comment
49-79 lb (22-36 kg)	Graco	Booster Basic	Belted

- ① 16-33 in (40-83 cm)
- ② 30-41 in (76-105 cm)
- ③ 39-59 in (100-150 cm)
- ④ 49-79 lb (22-36 kg)



Anti-theft System*

Anti-theft System*

Arming the system

1. Switch the ignition off.
2. All occupants get off the vehicle.
3. Lock all doors. This makes the anti-theft indicator steady on. The anti-theft alarm system will arm automatically after eight seconds, and the anti-theft indicator will then begin to flash.
4. You can leave the vehicle after confirming that the indicator begins to flash. Since unlocking the door from inside the vehicle will activate the system, never let anyone stay in the vehicle with the system enabled.

Triggering the alarm

- The system, when armed, will raise an alarm* with flashing turn signals in any of the following situations:
 - Any door, boot, or bonnet is opened without using the keyless access function of the smart key.
 - Use the mechanical key to unlock the vehicle.

Disarming the system

- Anti-theft alarm can be stopped by:
 - Unlocking the door with a valid smart key.
 - Use of an NFC to unlock the vehicle.
 - Use of the microswitch to unlock the vehicle.
 - Use of a valid smart key to remotely unlock the boot.
 - Starting the vehicle remotely with a valid smart key.
 - Pressing the START/STOP button inside the vehicle while carrying a valid smart key.

WARNING

- Do not modify the anti-theft alarm system by means of alteration or addition. Otherwise, the system may fail.

Anti-theft Indicator*

When the alarm is armed, the anti-theft indicator is solid on for eight seconds.



Data Collection and Processing

Data Collection and Processing

- This section provides you with some important information on how personal data is collected and processed when you use a BYD vehicle.
- For a more detailed overview on data processing, data protection and data subject rights, please read the current version of the privacy policy for the vehicle available at the infotainment system  (**Vehicle Settings** → **System Settings** → **More** → **Privacy Policy**).
- This vehicle is equipped with an Event Data Recorder (EDR). EDR mainly records data in the event of a crash or near-crash (for example, airbag deployment or hitting on a roadside obstacle) to help comprehend the vehicle system operation, such as:
 - Vehicle velocity
 - Tyre pressure condition
 - Adaptive cruise control (ACC) system status
 - Whether the seat belt is fastened

- The vehicle records EDR data only when there is a crash or when a near-crash event reaches a certain extent. The EDR does not record any data during the normal driving of the vehicle.
- The data recorded by the EDR system provides an understanding of the state of the vehicle's safety-related systems when an accident occurs, so that relevant parties can analyse the accident.
- The EDR data needs to be accessed and read by special equipment. BYD discloses your personal data to third parties only if this is legally permissible or you have consented to it. In addition to the vehicle manufacturer, third-party agencies with professional equipment (such as government agencies) can also read the EDR data if they have access to the vehicle EDR and equipment (for example, they can read the data of SRS control unit to clarify the accident).

Vehicle Data Processing

- Data is collected when the vehicle is used, such as data collected or transmitted by vehicle sensors or control units, which is necessary for the safe functioning of your vehicle.
- In some cases, the data is used to support driving (driver assistance systems) or to enable a specific comfort or infotainment function.
- Personal data that is collected and processed mainly include in-vehicle data, remote-services-related data, and other data, as further specified below.

In-vehicle data

Operation data

- When the vehicle is used, various vehicle status data (e.g., speed, battery level, and braking system) or environment (e.g., distance sensors and temperature) data is collected and processed.
- This data is not usually stored, but there are control units, sensors or other components installed in the vehicle that record such data, for example, to record maintenance requirements, error messages, or other information.
- The in-vehicle data will only be stored in the equipment in the vehicle but can be read out via the legally required OBD ("On Board Diagnostics") interface, for example, by BYD authorised dealer or service provider or other third parties.
- In case this access takes place during vehicle maintenance, the information can also be transmitted to BYD engineers for quality assurance, product defect reports, or customer claim verification.

Remote-services-related data

Remote supporting svrvice

- These include remote supporting services such as remote diagnosis and over-the-air (OTA) updates and upgrades for security and safety purposes (subject to owner's approval).
- These services serve the following purposes: service provision (remote support/diagnostics), product development, and security/public safety.
- Depending on the country and setup, various vehicle information can be transmitted to BYD's data centre in corresponding market for the above purposes, including vehicle location information, vehicle status, such as

energy consumption, vehicle speed, gear position, power mode, ESC status, steering system status, battery status, powertrain status, and overall vehicle performance status.

Other

Infotainment system

- Depending on vehicle configuration, data can be added to the infotainment system by the users themselves, such as media data for playing video on the infotainment system, address data for use in the navigation system, or data for use in online services.
- Depending on vehicle configuration, individual settings on the vehicle can also be entered.
- Data stored in the vehicle can be deleted at any time.
- BYD in-vehicle third party application collects data by themselves (from the use of third-party content, in particular as part of an online service).

Integration of mobile devices

- Depending on vehicle configurations, mobile devices can be connected and controlled through the vehicle's infotainment system.
- It may be necessary that the device's screen or audio is displayed/played through the infotainment system or transmitted to it.
- Additional data like positioning or vehicle information can be transmitted through applications for use in certain navigation systems, communication, or other third-party services.
- The specific type of data processing depends on the respective function and is controlled by the user or third parties such as the provider of the devices or corresponding services.

Internet access and connected services



- Depending on vehicle configurations, the Internet can be accessed for certain functions or BYD services through the vehicle's infotainment system network devices.
- BYD is not liable for any such services provided by any other party.
- In such cases, please obtain information about the use of data from the provider of the respective online service.

Camera image recording

- Your vehicle is equipped with a number of cameras/sensors.
- The reason for this is that some vehicle functionalities require the vehicle's path to be detected and assessed which is done by cameras that detect objects in the vehicle's surroundings (e.g., obstacles).
- The images are transmitted to the respective control module for further analytics required to operate the systems.
- Some images are just processed on a volatile basis (RAM), others may be stored, depending on vehicle equipment.
- For more camera details, see section "Panoramic View System" in this manual.

Permanent Vehicle Transfer to Third Parties and Offline Mode

- In case of a permanent vehicle transfer, i.e., second hand vehicle, or vehicle transfer by a third party for permanent use, it must be noted that any personalisation/user settings made via the infotainment system (e.g. address list, navigation system, etc.) may be accessed by the new owner.

- You can also restrict your vehicle's communication with the BYD data server and the processing of vehicle-related and personal data by setting the vehicle to offline mode.
- On the infotainment touchscreen, tap  to turn Wi-Fi off.
- This can also be done by tapping  → System Settings → Internet → WLAN → Off.

Disclosure of Personal Data to Authorities

- BYD will not disclose your personal data to third parties unless this is legally permissible or you have consented to it.
- However, subject to applicable laws, government agencies may be authorised to read out data from vehicles (for example, data can be read from the airbag control unit to clarify an accident).
- If required by law, BYD may also be obliged to disclose data upon request to governmental authorities in your country, such as in the investigation of a criminal offence.

Your Data Protection Rights

- BYD has staunch respect for its customer's privacy, and strictly complies with all data protection laws, in particular the General Data Protection Regulation (GDPR) and applicable local laws.
- According to these laws, owners have specific rights when their personal data is processed:
 - Data subjects have the right of information and access, to rectification, erasure of personal data

("right to be forgotten") and the right to object to the processing of personal data or to restrict it (or to withdraw consent given earlier, as well as the right to data portability).

- These rights may be limited in some cases. For example, if we can show that we have a legal obligation to process your data, or if providing the information to you would disclose personal data about another person, or if we are legally prevented from disclosing that information.
- In some cases, this may mean that we can retain the data even if you withdraw your consent.
- For more information on data processing, data protection, and any rights you may have, please visit the latest version of the Privacy Policy available at the infotainment system

(Tab  → **System Settings** → **More** → **Privacy Policy**).

02

INSTRUMENT CLUSTER

Instrument Cluster.....32





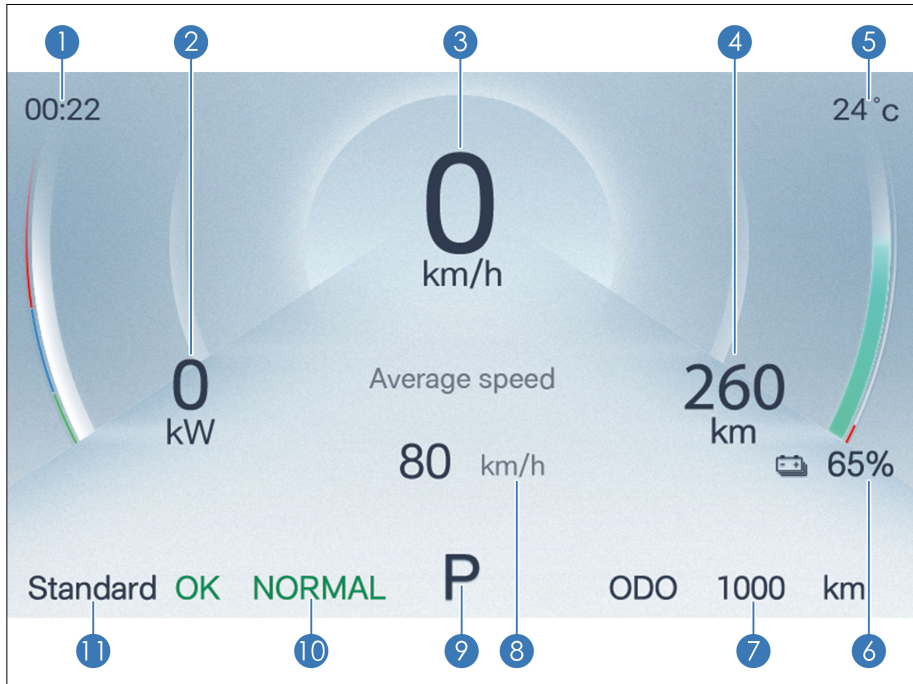













Instrument Cluster

Instrument Cluster View



- | | | | |
|---|-------------------------|----|----------------------|
| 1 | Time | 7 | Total mileage |
| 2 | Power meter | 8 | Average speed |
| 3 | Speedometer | 9 | Gear status |
| 4 | Remaining driving range | 10 | Driving mode |
| 5 | Outside temperature | 11 | Regenerative braking |
| 6 | State of charge (SOC) | | |

Instrument Cluster Indicators

	High beam indicator		Position light indicator
	Turn signal indicator	NORMAL	Normal mode
OK	OK indicator		ACC status indicator*
	AVH indicator (solid grey when AVH is in standby mode)		Driving power limit warning light
	Main alarm indicator		Smart key warning light
	ABS fault warning light		ESC OFF warning light
	ESC fault warning light		Tyre pressure fault warning light
	Driver attention warning light*		CPD indicator/warning light*
	Rear fog light indicator		Parking system fault warning light
	Steering system fault warning light		Seat belt reminder indicator
	Motor coolant overheating indicator		High-voltage battery charging connection indicator
	Low-voltage power system fault warning light		High-voltage battery overheating warning light



High-voltage battery fault warning light



Powertrain fault warning light



EPB indicator



Airbag fault warning light

Warning Light/Indicator Description



Smart key warning light

- If the key is not in the vehicle when you press the START/STOP button, this warning light comes on for a few seconds, a beep sounds, and the message "No key detected, please confirm if the key is in the vehicle" is displayed on the instrument cluster.
- If you press the START/STOP button while an electronic smart key matching the model is in the vehicle, this warning light does not light up. The vehicle can now be powered on.
- If the warning light flashes after you press the START/STOP button, it indicates low battery of the key.
- If the key is not in the vehicle, the instrument cluster prompts "No key detected, please confirm if the key is in the vehicle".



ABS fault warning light

- This warning light comes on when the ignition is on. If the anti-lock braking system (ABS) is working properly, the light goes out in a few seconds. Thereafter, if the system fails, the light lights up again until the fault is cleared.
- When the ABS fault warning light is on (with the parking system fault warning light off), the braking system continues to operate whereas the ABS does not.

- When the ABS fault warning light is on (with the parking system fault warning light off), since the ABS system does not operate, the wheels will be locked in case of emergency braking or braking on a slippery road.
- If any of the following cases occurs, it means there is a fault in components monitored by the warning light system. In that case, contact a BYD authorised dealer or service provider for vehicle inspection as soon as possible.
 - This warning light does not come on or is steady on when the ignition is on.
 - This warning light turns on during driving.



REMINDER

- A warning light that lights up briefly during operation does not indicate a problem.
- If the parking brake system warning light and the ABS warning lights light on at the same time, stop the vehicle safely right away and contact a BYD authorised dealer or service provider. In this case, if brakes are applied, the ABS will not work and the vehicle will become extremely unstable.
- If both ABS indicator and the braking system indicator come on and the electronic parking brake (EPB) is fully released, the braking force distribution system of front and rear wheels has also failed.



Tyre pressure fault warning light

- This warning light comes on when the ignition is on. It turns off in a few seconds if the tyre pressure monitoring system is working properly. If the system fails, this warning light turns on again.
- When the tyre pressure fault warning light comes on or flashes, the message "Please check TPMS" is displayed on the instrument cluster, and the tyre pressure is displayed as "---", it indicates that the tyre pressure system is faulty.
- When the tyre pressure value displays "Abnormal Signal", it indicates that the tyre pressure signal at the location of the vehicle may be disturbed or the tyre pressure monitoring module is damaged.
- When the tyre pressure fault warning light is solid on and one or more values turn yellow on the tyre pressure screen on the instrument cluster, the corresponding tyre is in under-pressure condition. When the temperature value of one or more tyres turns yellow, it indicates that the tyre temperature is too high.

In the event of any of the situations above, it is recommended to contact a BYD authorised dealer or service provider for inspection as soon as possible.



ESC fault warning light

- This warning light turns on after the vehicle is started. If electronic stability control (ESC) functions properly, the light goes out in a few seconds. If ESC is faulty, this light comes on again until the fault is cleared.

- If the ESC warning light flashes temporarily while the vehicle is in motion, it indicates the ESC system is working.
- When the ESC warning light turns on (with the ABS fault warning light and the parking system fault warning light off), the ESC fails, but the ABS and the braking system continue to operate normally.
- When the ESC warning light turns on (with the ABS fault warning light and the parking system fault warning light off), the ESC system does not work. This means the vehicle is extremely unstable at sharp turns or when the driver steers away from obstacles ahead.
- If any of the following cases occurs, it means there is a fault in components monitored by the warning light system. In that case, contact a BYD authorised dealer or service provider for vehicle inspection as soon as possible.
 - This warning light remains off (self-check not performed) after the vehicle is started.
 - This warning light is steady on while driving.



REMINDER

- A warning light that lights up briefly during operation does not indicate a problem.
- If the ESC warning light remains on while the warning lights for the ABS and the braking system are on, immediately stop the vehicle in a safe place and contact a BYD authorised dealer or service provider. This is because braking at this time can render the vehicle extremely unstable, and the anti-

! REMINDER

lock braking system does not work at all.



ESC OFF warning light

- When the ESC OFF switch is pressed, this warning light should remain steady on and the ESC system will not operate. When the ESC OFF switch is pressed again, this warning light should turn off and the ESC system resumes its normal operation.

! REMINDER

- While the ESC OFF warning light is on, the driver must stay alert and keep driving at a lower speed when making a sharp turn and when avoiding an obstacle which appears suddenly, because braking at this time can render the vehicle unstable, given the malfunction of ESC system.



Driving power limit warning light

- When the level of the high-voltage battery is low and the motor power is limited, this indicator will light up, and it is recommended to contact a BYD authorised dealer or service provider immediately.



Main alarm indicator

- If this indicator goes on, check the fault prompt or warning on the instrument cluster.



CPD indicator/warning light*

- CPD indicator*: If child presence detection (CPD) is turned off, the indicator is solid on, and the OFF reminder lasts for five seconds. Tap **ON** or **Delay**. The indicator turns off and CPD is enabled.
- CPD warning light*: If the CPD fault reminder lasts for five seconds and the indicator is solid on, it indicates that the CPD system fails. It is recommended to bring the vehicle to a BYD authorised dealer or service provider for inspection.



Driver attention warning light*

- Driver attention warning (DAW) system evaluates the driver's degree of fatigue by the vehicle operation status. The driver would be reminded according to the evaluation results to ensure driving safety.



Seat belt reminder indicator

- With the ignition switched on, if any passenger on the front seats or rear seats has not buckled up, the seat belt reminder indicator lights up. It remains on until the seat belt is fastened.



Airbag fault warning light

- With the ignition switched on, this warning light turns on and then goes off in a few seconds if the airbag system is working properly. This warning light is used to monitor the airbag ECU, collision sensors, inflation device, warning lights, connections, and power supply.
- If any of the following cases occurs, it means there is a fault in components monitored by the warning light system. In that case, contact a BYD authorised

dealer or service provider for vehicle inspection as soon as possible.

- When the ignition is switched on, this warning light remains off or is solid on after the ignition is switched on.
- This warning light turns on during driving.

Parking system fault warning light

- When the brake fluid level is low and the braking system is faulty, this warning light lights up. If any of the following conditions occurs, immediately park the vehicle in a safe place. It is recommended to contact a BYD authorised dealer or service provider.
- This warning light comes on when the ignition is switched on and the brake fluid level is low.

REMINDER

- When the brake fluid level is low, park the vehicle because it is dangerous to continue driving.
- This warning light is solid on although after starting the vehicle, the brake fluid level and EPB system operation are normal (the EPB is engaged and released normally, and the message "Please check the EPB" is not displayed).
- Fault warning lights for parking brake and ABS come on simultaneously.

REMINDER

- A warning light that lights up briefly during operation does not indicate a problem.

Steering system fault warning light

- When the steering system is faulty, this warning light is steady on. It is recommended to bring the vehicle to a BYD authorised dealer or service provider for inspection.

REMINDER

- The steering system features an electric motor to reduce the force required to turn the steering wheel.
- When turning the steering wheel, a hum may be heard coming from the running motor. This does not indicate that the motor is faulty.
- Do not turn the steering wheel to its limit position for more than five seconds, otherwise the temperature protection will be activated and the steering system will be damaged or steering will become heavy.
- If you have turned the steering wheel frequently with the vehicle staying put for a long time, the steering wheel may become difficult to turn even if the warning light does not turn on. This is not a fault.
- To prevent steering system overheating, the power assist effect will be reduced if the steering wheel has been frequently turned with the vehicle staying put for a long time. As a result, the steering wheel become difficult to turn. In this case, reduce steering frequency or power off the vehicle. The system will recover within 10 minutes.

WARNING

- If the steering system warning light goes on, immediately park the vehicle safely, and contact a

WARNING

BYD authorised dealer or service provider.



Low-voltage power system fault warning light

- If this warning light turns on while driving, it indicates that there is a problem with the low-voltage power supply. Turn off devices such as the A/C, fan, and radio, and pull over the vehicle immediately if it is safe to do so. It is recommended to contact a BYD authorised dealer or service provider for rescue as soon as possible.
- Charging and discharging stop when this warning light turns on.
- When this warning light lights up and remain steady on while driving, the vehicle speed will be limited.
- This light is used to warn about the operating state of the DC module and the low-voltage battery module when the vehicle is not being charged or discharging.



Powertrain fault warning light

- If the powertrain fails, this warning light turns on.
- If any of the following cases occurs, it means there is a fault in components monitored by the warning light system. In that case, contact a BYD authorised dealer or service provider for vehicle inspection as soon as possible.
 - This warning light is steady on when the ignition is switched on.
 - This warning light turns on during driving.

CAUTION

- Try not to drive the vehicle when the warning light is on. Contact a BYD authorised dealer or service provider to check the problem as soon as possible.



High-voltage battery overheating warning light

- If this indicator is on, it indicates that the high-voltage battery temperature is too high and the vehicle must be stopped to cool down. When the warning light flashes, it is recommended to immediately stop the vehicle safely and leave the vehicle as soon as possible.
- The high-voltage battery may overheat under the following operating conditions:
 - Driving up a slope for a long time in hot weather.
 - Long period of stop-and-go traffic condition, frequent rapid acceleration, frequent hard braking, or vehicle running for a long time without pause.



High-voltage battery fault warning light

- This warning light comes on when the ignition has just been switched on. If the high-voltage battery system is working properly, this warning light will turn off in a few seconds. Thereafter, if the system fails, this light will light up again. It is recommended to contact a BYD authorised dealer or service provider for inspection as soon as possible.
- If any of the following cases occurs, it means that there are faults in the components monitored by the

warning light system. In such case, it is recommended to contact a BYD authorised dealer or service provider for vehicle inspection as soon as possible.

- This warning light is steady on when the ignition is on.
- This warning light is steady on or occasionally turns on while driving.











Motor coolant overheating indicator

- If this indicator is solid on, it indicates that the motor coolant temperature is too high. Park the vehicle in a safe area until this indicator goes out.

Other Instrument Cluster Fault Prompts

The instrument cluster may display the following fault prompts. Handle them as recommended:

Symbol	Error Message	Response
	Please check the OBC system	The on-board charging system is faulty. In this case, check the charging connection, and reconnect the charging equipment. If the fault persists, contact a BYD authorised dealer or service provider.
	Vehicle network error, please pull over safely and contact BYD service	The vehicle may be disconnected from the data network. In this case, park the vehicle immediately at a safe place, and contact a BYD authorised dealer or service provider.
	EV power limited	The EV function is limited. Contact a BYD authorised dealer or service provider immediately.
	Please check the headlight	The headlight is faulty. In this case, contact a BYD authorised dealer or service provider.
	The AEB function is limited	The predictive collision warning and automatic emergency braking systems are faulty. In this case, park the vehicle, and contact a BYD authorised dealer or service provider.
	The BSD function is limited	The blind spot assist system is faulty. In this case, park the vehicle, and contact a BYD authorised dealer or service provider.
	The function of the LKS is limited	The lane departure assist system is faulty. In this case, park the vehicle, and contact a BYD authorised dealer or service provider.

Symbol	Error Message	Response
	Intelligent-camera is not available due to poor condition*	The intelligent camera is unusable. Check whether the visual field of the camera on the front windscreen is blocked by foreign objects or is foggy. If not, contact a BYD authorised dealer or service provider.
	Please check the gear*	The shifter controller is faulty. In this case, park the vehicle immediately, and contact a BYD authorised dealer or service provider.

03

CONTROLLER OPERATION

Doors and Keys.....	42
Seats.....	51
Steering Wheel.....	55
Switches.....	58

Doors and Keys

Keys

Smart Key

Lock or unlock all doors by pressing the driver's door microswitch while carrying the electronic smart key. Buttons on the key help you lock or unlock doors, open the boot, and start the vehicle remotely.

- ① Indicator
- ② Lock button
- ③ Unlock button
- ④ Boot release button
- ⑤ Start/Stop button
- ⑥ Mechanical key

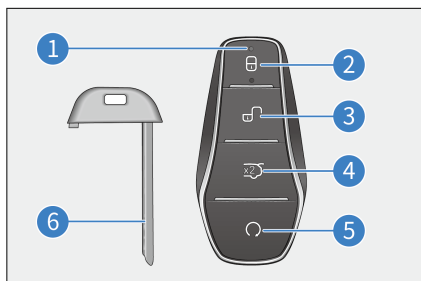

Anti-forget key function

- If the key is placed in the vehicle or in the boot with the vehicle locked, when you close the boot, the vehicle automatically unlocks and turn signals flash twice.

WARNING



 Button battery safety

alert:

- The button (coin) battery in the smart key is hazardous and both

WARNING

new and used batteries are to be kept away from children at all times.

- If swallowed or placed inside any part of the body, a lithium button battery can cause severe or fatal injuries in two hours or less.
- Medical attention should be sought immediately if it is suspected the button battery has been swallowed or placed inside any part of the body.

CAUTION

- The smart key is an electronic component. Observe the following instructions to prevent damage to the key:
 - Do not expose the smart key to high temperatures, such as on the dashboard.
 - Do not disassemble the smart key without authorisation.
 - Do not let the smart key hit other objects or fall down.
 - Do not immerse the key in water or clean it in the ultrasonic scrubber.
 - Do not place smart keys with devices that emit electromagnetic waves, such as the mobile phone.
 - Do not attach to the smart key any objects (such as a metal seal) capable of cutting off electromagnetic wave signals.
 - You can register a spare key for the same car. In this case, contact a BYD authorised dealer or service provider immediately.

 **CAUTION**

- If the electronic smart key cannot operate the door within the normal distance, or the key indicator light is dim or off:
 - Check for nearby radio stations or airport radio transmitters that interfere with the normal operation of electronic smart keys.
 - The smart key battery may be exhausted. Check the battery inside the electronic smart key. It is recommended to contact a BYD authorised dealer or service provider for inspection as soon as possible.
- If the smart key is lost, contact a BYD authorised dealer or service provider as soon as possible to prevent theft or accidents.
- Do not change the transmission frequency arbitrarily, increase the transmission power (including additional transmission frequency amplifier), or arbitrarily connect the external detection antenna or switch other transmitting detection antennas.
- Do not generate harmful interference to legal radio communication services when using the smart key. Once any interference is found, stop using the smart key immediately, and take measures to eliminate the interference before continuing to use it.
- The use of micropower radio equipment must be free from interference of all radio services or from radiation of devices for industrial, scientific and medical applications.

 **CAUTION**

- Do not use it near aircraft or airports.
- People implanted with pacemakers or defibrillators should stay away from the detection antennas of intelligent entry and start systems, as electromagnetic waves can affect the normal use of such devices.
- In addition to people implanted with pacemakers or defibrillators, those who use other electronic medical devices should also consult the manufacturer on the use of such devices under the influence of electromagnetic waves. Electromagnetic waves may bring unknown consequences to the use of such medical devices.
- When leaving the vehicle, always carry your key and lock the vehicle. Never leave anyone (especially children) alone in the vehicle.

Mechanical Key

Use the mechanical key (inside the smart key) to lock or unlock the driver's door. Insert the mechanical key back into the smart key when it is not in use.

Taking out the mechanical key

- Press the "PUSH" button on the smart key ②, and take out the mechanical key in the direction indicated by ①.

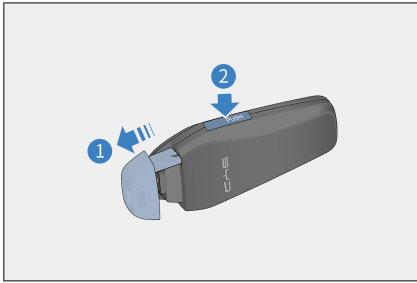

- Press the "PUSH" button and insert the mechanical key back into the smart key when it is not in use.

Bluetooth Digital Key *

- You can use the BYD Bluetooth digital key to control the vehicle through a close-range mobile phone Bluetooth connection, including locking or unlocking the doors.
- You can download and install the latest BYD App in the app market. The function of Bluetooth digital key can be found in the app.
- For vehicles supporting Bluetooth digital key, you can use the key after activating it in the BYD App.
- Turn on the Bluetooth on your phone, approach the vehicle, and open the BYD App for automatic Bluetooth digital key connection. You can also connect it manually. The key is effective after Bluetooth is connected.
- The specific functions supported by the key are subject to the vehicle configuration. The key can be used without network. After the key connection, you can select operations, and the app will immediately send commands to control the vehicle.
- In some countries or regions, according to relevant regulations, when a user starts the vehicle, the vehicle will detect the position. The

vehicle can be started only when it detects that the Bluetooth digital key is within two meters of it to ensure the vehicle property safety.

! CAUTION

- Before activating the Bluetooth digital key, ensure that the vehicle network is well connected. If the activation fails, try to move the vehicle to a place with good network and activate the key again in the application.
- After the vehicle is unlocked with a Bluetooth digital key, the doors will lock automatically if there is no operation in a short time.
- When the key connection or operation fails for many times, you can turn the Bluetooth off and then on, or restart the application.
- Limited by the vehicle environment and mobile phone performance, the effective distance of the key will be reduced in case of dense vehicles.
- There are a few mobile phones that are not compatible with bluetooth digital keys.

NFC 卡片钥匙*

Illustration

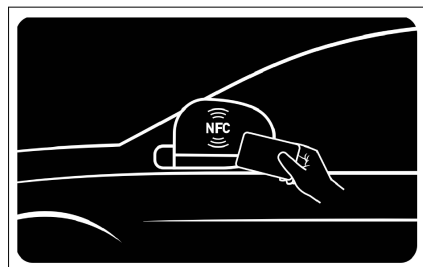

NFC Digital Key*

- The NFC digital key is a function provided by BYD for users. You can register smartphones or wearable devices as vehicle keys to unlock, lock, and start the vehicle.
- Before activating the NFC digital key, ensure that:
 - The vehicle has been equipped with BYD Cloud Service.
 - Your vehicle supports NFC digital key.
 - Your smartphone or wearable device supports BYD NFC digital key (contact a BYD authorised dealer or service provider for device compatibility).

Activating the NFC digital key of mobile phone

Before activating, start the vehicle and shift into Park with a valid smart key.

There are three ways:

- Via BYD App:
 - Download and log into the BYD app in the APP store. Tap digital key to enable the function according to the instructions.
- Via email links:
 - Log in to the email account reserved when purchasing the vehicle on the phone, and activate the digital key according to the instructions in the email from BYD (bydapp@byd.auto).
- Via the infotainment touchscreen:
 - On the infotainment touchscreen, tap  → **Vehicle** → **Locks** → **Digital key** to activate the key according to the instructions.

Activating the NFC digital key on wearable devices

Supported wearable devices include Apple Watch (consult a BYD authorised

dealer or service provider for other supported devices), and there are two ways of activation:

- Synchronize the key from iPhone to Apple Watch:
 - After successful key activation on iPhone, activate the key on iPhone when wearing an unlocked watch. After activation, iPhone synchronously prompts to add a digital key on the nearby bound Apple Watch. Activate it according to the instructions.
- Via the Watch app:
 - If the iPhone NFC key is active but not synced to Apple Watch, open the Watch app on iPhone, select **Wallet**, find the key, and tap **Add** to activate the key following the instructions.

Using the NFC digital key

Ensure the NFC function is enabled on your device before using the NFC digital key. Here is how to use:

- To unlock/lock the vehicle, position the NFC antenna area of the smartphone or wearable device near the NFC sign on the driver side mirror. Consult the manufacturer for the NFC antenna area of your device.
- To authorise vehicle start, place the smartphone or wearable device at the NFC sign inside the vehicle.



CAUTION

- After authorizing vehicle start with the NFC digital key, start the vehicle promptly, or you need to place the device at the NFC sign again to reauthorise.

Removing the NFC digital key

You can remove the NFC digital key in any of the three ways:

- Via the BYD app:
 - Open the BYD app and navigate to the digital key management screen, select the key to remove, and enter the password to remove it.
- Via the infotainment touchscreen:
 - With a valid smart key inside the vehicle, go to infotainment touchscreen → 🚗 → **Vehicle** → **Locks** → **Digital key** and follow the instructions to remove the key.
- Via the Wallet app:
 - Open the Wallet app on the phone, select the digital key, and remove it following the instructions.

Locking/Unlocking Doors

Locking/Unlocking with Mechanical Key

Lift the outer handle of driver's door upward, insert the key into the lock hole, and turn it.

- Unlocking: Turn the key clockwise.
 - After unlocking with the mechanical key, pull it out, and pull the outer handle to open the door.

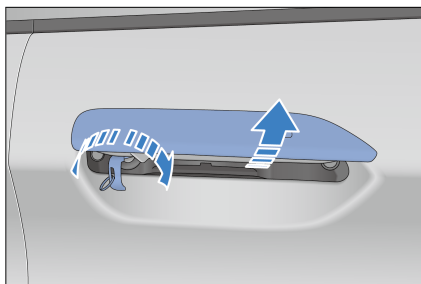

- Locking: Turn the key counterclockwise.
 - Close the driver's door, make sure that it is flush with or lower than

the rear right door, press the door, and turn the key counterclockwise to lock.

Opening with Interior Door Handle

- When the vehicle is unlocked, pull the handle once to open the door from inside the vehicle.
- When the vehicle is locked, pull the handle twice to open the door from inside the vehicle.

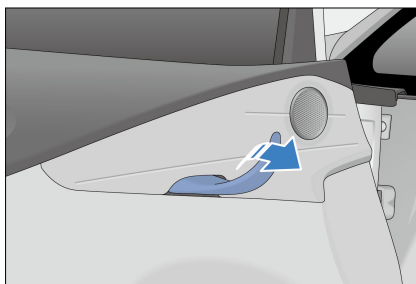

⚠️ WARNING

- Do not allow children to play with the door handle, so as to avoid door opening while driving.
- If there are children in the vehicle, make sure to enable the child protection lock function.

⚠️ CAUTION

- As this vehicle is equipped with a child protection lock, the rear doors can only be opened with the interior door handle when the child protection lock is disabled.

Locking/Unlocking/Finding the Vehicle with Smart Key

The wireless remote control is used to unlock or lock all doors at a

close distance, and complete additional functions.

In the active area, press the associated button on the registered smart key to lock or unlock all doors.

Locking

- When all the doors and the bonnet are closed, press the lock button to lock all doors. The turn signals flash once. Check whether all doors are securely locked.
- If any door is not closed, the turn signals do not flash, and the alarm sounds once.
- If the ignition has not been switched off, the turn signals do not flash and the alarm sounds once.



Unlocking

- Press the unlock button to unlock all the doors at the same time. The turn signals flash twice.
- When you unlock all the doors with the smart key, even if no door is opened, the interior lights stay on for 15 seconds and then go out.
- If the anti-theft alarm system is armed, open any door within 30 seconds after unlocking with the smart key, or all doors will relock automatically.
- Even if you press and hold the lock or unlock button, locking or unlocking will not be repeated. You need to release the button and press it again.

Lowering windows

- Press and hold the unlock button on the smart key to lower the four windows.

Unlocking the boot with smart key

- Double-press the boot release button on the smart key. The turn signals then flash twice.

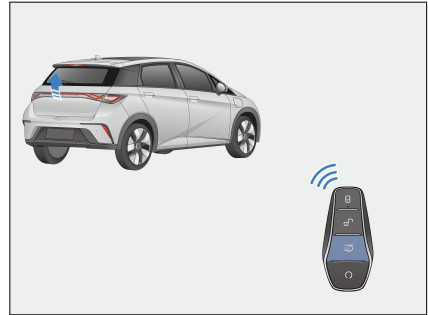

Finding the vehicle

- With the anti-theft alarm system armed, pressing the lock button makes the vehicle sound a long beep and turn signals flash 15 times. Use this function to locate the vehicle when it cannot be found.
- When the vehicle is in car search mode, press the lock button again. The vehicle enters the next car search mode.

Unlocking/Locking Doors with Microswitch

Unlocking/Locking Doors with Microswitch Illustration

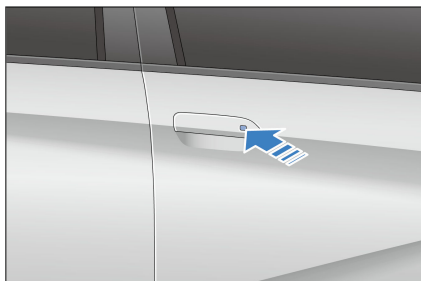

Unlocking the Boot with Microswitch

- With the vehicle locked, press the rear microswitch while carrying a valid key to unlock the boot.
- With the vehicle unlocked, press the rear microswitch to open the boot.

Locking/Unlocking with NFC Key Card

- Hold the NFC card close to the NFC sign on the side mirror on the driver's side.

Locking doors:

- With the ignition switched off and all doors closed but not locked, place the NFC key card close to the NFC mark on the side mirror on the driver's side to simultaneously lock all the doors. The turn signals flash once.

Unlocking doors:

- With the anti-theft alarm system armed, place the NFC key card close to the NFC mark on the side mirror on the driver's side to simultaneously unlock all the doors. The turn signals flash twice.
- If the alarm is activated, open a door within 30 seconds after unlocking with

the NFC key card, or all doors will relock automatically.

- Putting the NFC key card close to the NFC mark on the side mirror on the driver's side does not work if:
 - When the door is opened or closed, place the NFC key card close to the NFC mark on the side mirror on the driver's side.
 - The ignition is not switched off.

Emergency Boot Releasing from the Inside

1. Remove the access cover of the boot lid lock from the lid trim panel.

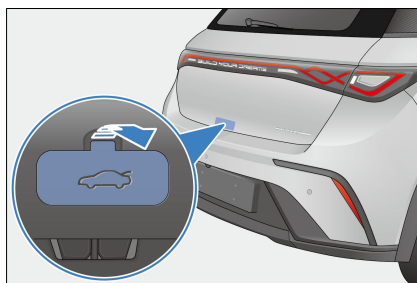

2. Pull the lever to unlock the boot lid.

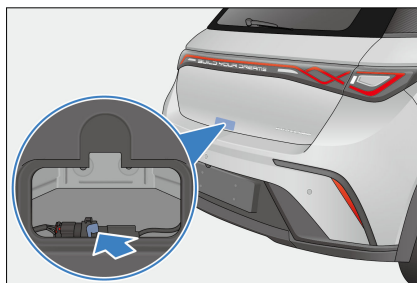

⚠ CAUTION

- When the vehicle is powered off, the boot can be unlocked from the inside in case of emergency.



CAUTION

- Never try to deliberately activate the anti-pinch function.

Locking/Unlocking with Central Locking

Locking or unlocking the vehicle with the central locking

See **P64**.

Locking or unlocking doors automatically

- All doors lock automatically at vehicle speeds above 5 mph (8 km/h).
- Press the START/STOP button to switch the ignition off. Then, all doors unlock automatically.

Locking/unlocking all doors concurrently

- With the anti-theft alarm system disarmed, the backlight of the central lock button turns on if the vehicle is locked and off if the vehicle is unlocked.
- Pressing the central lock button locks all doors so that any attempt to open any door from the outside fails. At this time, pull the interior handle to unlock a door and pull a second time to open it.



REMINDER

- All doors unlock automatically when the vehicle suffers a strong impact, depending on the impact intensity and accident type.

Emergency Vehicle Locking with Mechanical Key

- When the central locking fails, use the key to turn the emergency locking

knobs of the passenger's doors to lock these doors (turn the left door knob clockwise; turn the right door knob counterclockwise), then close the doors. Finally, lock the driver's door by the mechanical key. In this case, all vehicle doors are locked and impossible to open using their outer handles.



- To unlock the doors, unlock the driver's door with the mechanical key first, then enter the vehicle, and pull the inner handles of other doors. To open these, pull their outer handles or pull their inner handles again.



REMINDER

- Prevent excessive force from distorting or breaking the key during the operation.

Smart Access and Start System

Access

Use the smart key to unlock or lock vehicle doors. See **P46** or **P**.

Start-up

With the smart key inside, press the brake pedal and the START/STOP button to start the vehicle. (See **P96**.)

Antenna positions

- ① Interior antenna
- ② Exterior antenna

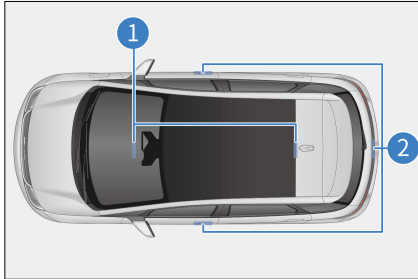

Active area

The smart access and start functions take effect only when the registered smart key is within the active area.

- ① Active area of the access function: about 1 meter from the front door handle and the exterior boot switch.
- ② Active area of the start function: inside the cabin.

If another smart key is near this vehicle's smart key, unlocking may take longer than usual, which is normal.

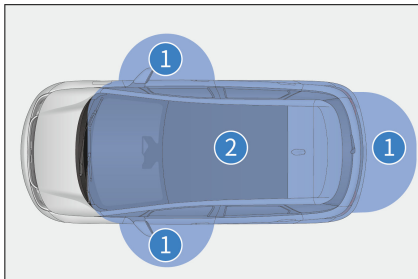

! REMINDER

In the following situation, smart access and start system may not work normally:

! REMINDER

- There is a strong electromagnetic field nearby, such as TV towers, power stations, and broadcasting stations.
 - The smart key is being carried along with a communication device, such as a two-way radio or mobile phone.
 - The smart key is in contact with or covered by a metal object.
 - The door handle is operated too quickly.
 - The smart key is too close to the handle.
 - Another wireless remote control function is being used nearby.
 - When the smart key battery runs out.
 - The smart key is close to high-voltage equipment or equipment that produces noise.
 - The smart key is being carried along with another smart key or radio-wave-emitting device.
 - Even within the active area, the smart key may not work properly in certain locations, for example, on the dashboard, in the glove box or on the floor.
- If the smart access system is not working properly and it is impossible to enter the vehicle, the mechanical key can be used to lock/unlock the driver's door, or the wireless remote control function can be used to lock/unlock all doors.
- Pressing the Start/Stop button may not enable the start function due to:
- Smart key failure. If the smart key warning light comes on and

a message ("Low key battery, please replace the battery soon") is displayed on the instrument cluster, the battery of the key may be exhausted.

- If the smart access and start system cannot work properly due to system failures, bring all smart keys to a BYD authorised dealer or service provider for repair.

Saving battery power

- The smart key communicates with the vehicle even when the vehicle is not running. Therefore, do not leave the smart key in the vehicle or within 6.6 ft (2 meters) from the vehicle.
- Receiving strong electromagnetic waves for a long time drains the battery of the smart key quickly. The smart key must be kept at least one meter away from electrical equipment that generates a magnetic field, such as the following devices:
 - TVs
 - PCs
 - Wireless telephone chargers
 - Electroliers
 - Fluorescent table lamps

Child Protection Lock

Child protection locks are designed to prevent children in rear seats from accidentally opening rear doors. Such locks are provided on the sides of the left and right rear doors.

- ① Unlock
- ② Lock

The door cannot be opened from inside the vehicle while the latch is locked. To open this door, use the exterior door handle.



CAUTION

- Before driving, especially when a child is in the vehicle, ensure that the doors are closed and the child protection lock function is enabled.
- Proper use of seat belts and activation of child protection lock helps prevent the driver and passengers from being thrown out of the vehicle in an accident, and also prevents a door from being opened accidentally.

Seats

Seat Precautions

- Adjust the driver's seat so that the pedals, steering wheel, and dashboard controls are within the driver's easy control.
- The most effective safeguard while driving is to keep the seatback upright, always resting well on the seatback, and adjusting the seat belt to the right position.
- Secure your luggage appropriately to prevent it from skidding or moving. Luggage in the vehicle should not be higher than seatbacks.

WARNING

- Sitting on a folded seatback, in the boot, or on cargo is prohibited. Improper seating position or improperly fastened seat belts can result in personal injury in case of emergency braking or a collision.
- Do not place any items under the seats. The driver may lose control of the vehicle because items placed there affect the seat locking mechanism or accidentally push up the seat position adjustment lever, causing the seat to move suddenly.
- When adjusting the seat, do not place your hand under the seat or near its operating parts, to prevent being crushed.
- After adjusting the seatback, lean back to confirm the seatback has been locked. Seatbacks that are not fully locked can cause personal injuries in an accident or emergency braking.
- Do not put the seatback down while driving or riding in the vehicle. This makes the shoulder strap of the seat belt not properly attached to the body. As a result, you and your passengers could hit the strap in an accident, causing serious injury to the neck or other parts; or you and your passenger may slip out of the waist belt, resulting in other serious injuries.
- Do not adjust the driver's seat while the vehicle is in motion, as unpredictable seat movement can cause the loss of vehicle control at this time.
- Do not drive the vehicle until occupants are seated properly.

REMINDER

- Adjust the seat position before fastening seat belts.
- While adjusting a seat, do not let it hit against any passenger or the luggage.

Adjusting Front Seats

Power front seat adjustment include seat position adjustment, cushion height adjustment*, and seatback angle adjustment. Choose the following methods according to the actual configuration of your vehicle.

Seat position adjustment switch

- Move this switch back or forth to slide the seat backward or forward.
- Move the rear end of the switch up or down to adjust the height of the seat cushion.

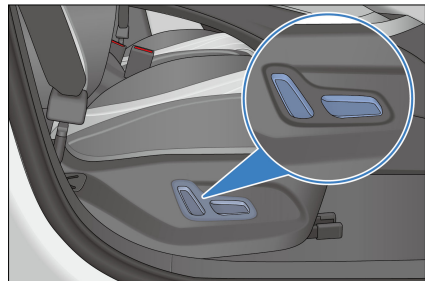

Seatback angle adjustment switch

- Move this switch forward or backward to adjust the seatback angle.

REMINDER

- Releasing the switch stops the seat in this position. Do not place anything under the seat as

! REMINDER

this may prevent the seat from operating.

Heating System*

- Turn the heating system on or off in infotainment touchscreen →  → A/C shortcut button → seat heating controls.
- You can also access the heated seat settings in the drop-down menu of infotainment system homepage.

Heating adjustment

- On the infotainment touchscreen, tap the seat heating controls to select a heating level: 1 or 2.
- This function is always disabled when the vehicle is just powered on.

Heating of the rear windscreen and side mirrors

- Enable or disable the heating of the rear windscreen and side mirrors by using the heating switch for the rear windscreen and side mirrors.

Folding Rear Seats

Pull the strap on the rear seat to fold the bench.

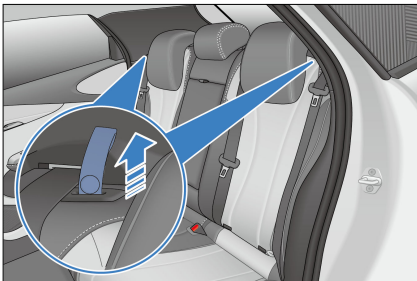

! REMINDER

- Please fold or unfold the rear seats at a moderate speed. Avoid quickly lowering or pulling up seatbacks to prevent damage to or malfunction of rear seats and the seat belts.
- When unfolding a rear seat, do not push the seatback hard; otherwise, the seatback will be pre-stressed and impossible to unlock.
- When unfolding a seatback, check that the buckle position is proper to expose the reserved opening on the seat.
- Do not turn over the seat when the seat belt latch is inserted into the buckle.

Head Supports

Lifting the head support

Lift the head support in the direction of the head post until it is in the appropriate position, and then release it until a locking sound is heard.

Lowering the head support

Press the head support adjustment button, lower the head support to a proper position, and then release the button.

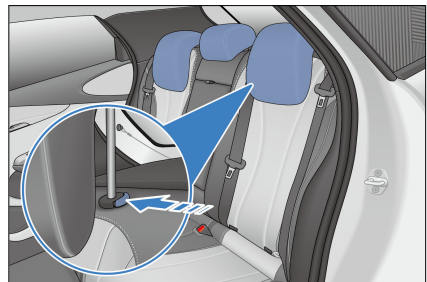

Removing the head support

Press and hold the head support adjustment button, remove the head support, and release the button.

Installing the head support

Insert the head support post into the bushing with the grooves facing forward. Press the head support adjustment button, push down the head support to a proper position, and then release the button.

REMINDER

- Head supports protect vehicle occupants from head and neck injuries. Adjust the head support so that its centre aligns with the back of your head for maximum protection. Adjust the

REMINDER

head support to the proper position based on your actual height.

- After adjusting the head support, ensure that it is locked into position.
- Do not drive the vehicle without head supports.
- Do not attach any object to the head support post.

Steering Wheel

Steering Wheel Switches

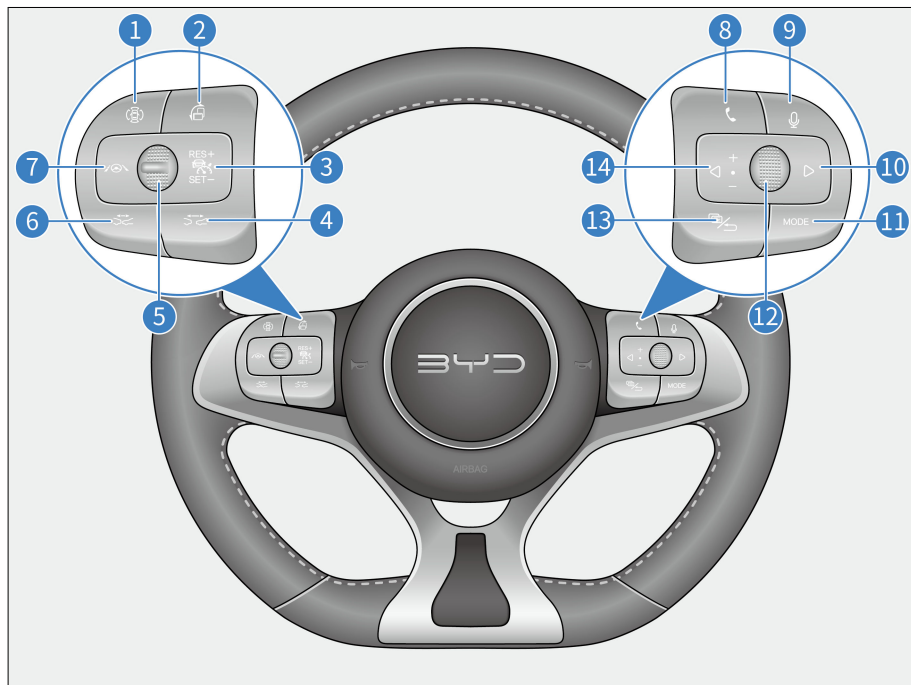

- | | | | |
|---|---|----|-------------------------|
| 1 | Panoramic view | 8 | Call |
| 2 | Whirling button | 9 | Speech recognition |
| 3 | Cruise control switch or +/Reset or -/Set | 10 | Right |
| 4 | Distance + | 11 | Mode |
| 5 | Lever | 12 | Scroll button |
| 6 | Distance - | 13 | Instrument cluster/Back |
| 7 | ICC | 14 | Left |

The audio control switch is operational when the ignition is switched on.

Left-hand buttons

Panoramic view

- Press this button to turn on/off the panoramic view system.

Screen mode

- Press this button to rotate the infotainment touchscreen.

+ / Reset*

- Activates the adaptive cruise control (ACC) system and uses the previous system settings.

ACC switch

- Turns the ACC system on or off.

- / SET*

- Sets the current speed to the target cruise speed.

Distance +

- Increases the distance from the vehicle ahead by one notch when the Adaptive Cruise Control (ACC) function is enabled. A total of four notches are available.

Distance -

- Reduces the distance from the vehicle ahead by one notch when the ACC function is enabled. A total of four notches are available.

ICC

- Press this button to turn on/off ICC.

REMINDER

- For instructions on using cruise control, see **P104** and **P108**.

Right-hand buttons

Scroll button

- Adjusting infotainment system volume when the instrument cluster is not in menu mode:
 - Roll the button upward to increase the volume. The button is non-operational when the volume reaches the highest.

- Roll the button downward to decrease the volume. The button is non-operational when the volume reaches the lowest.

- Press down the button to mute.

- When the instrument cluster is in menu mode:

- Roll the button upward to select the upper level-2 or level-3 menu items.

- Roll the button downward to select the lower level-2 or level-3 menu items.

- Press down the button to go to the next-level menu or confirm the current setting.

CAUTION

- The infotainment system is muted once the instrument cluster is set to the menu mode. To adjust infotainment system volume, exit the instrument cluster menu mode first.

Left/Right

- When the infotainment system is in radio mode:





- Press the ◀ button to select previous radio station.

- Press the ▶ button to select next radio station.

- When the infotainment system is in USB/Bluetooth music/third-party music app/other modes:

- Press the ◀ button to play the previous track (track number - 1).

- Press the ◀ button to select a record upward on the Bluetooth call record or phonebook page.

- Press the  button to play the next track (track number +1).
- Press the  button to select a record downward on the Bluetooth call record or phonebook page.
- When the instrument cluster is in menu mode:
 - Press the  button to switch to level-1 menu and its submenus on the left.
 - Press the  button to switch to level-1 menu and its submenus on the right.

Call

- Press this button to make or receive a call. (The audio system is muted at the same time.)
- When a Bluetooth-unrelated screen is currently displayed, press this button to switch to the phone selection screen if Bluetooth is disconnected, or to the Dial screen if Bluetooth is connected.
- After entering a phone number on the Dial screen or selecting a record on the Call Log or Contacts screen, press this button to dial the number.
- When Bluetooth is connected, but no phone number is entered on the Dial screen, press this button to switch to the Call Log screen. Press this button again to call the first dialed number on the call history.

Speech recognition

- Press this button for the infotainment touchscreen to switch to the voice recognition screen.
- Press this button again to re-enter a voice command.

Instrument cluster/Back

- When the instrument cluster is not in the menu mode, press this button to view the instrument cluster menu.
- When the instrument cluster is in menu mode, press this button to return to the upper-level screen, or to exit the menu if there is no upper-level screen.
- When on the Bluetooth call screen, press this button to end the call.

Mode

- Selecting a mode: Press the Mode button to switch between media apps, peripherals, and pre-installed third-party audio/video apps.

Horn

- Press the horn button area to honk the horn, and release to stop honking.

CAUTION

- Avoid pressing honking for too long, as the horn may be damaged.

REMINDER

- Observe the traffic laws and use the horn properly.

Adjusting the Steering Wheel

To adjust the steering wheel position, hold it and operate as follows:

- Push down the steering wheel adjustment handle, adjust the steering wheel to the desired position, and then return the handle to its original position.

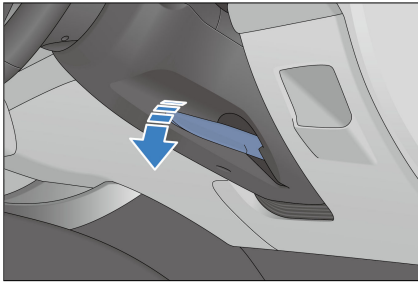

WARNING

- Never adjust the steering wheel while driving, as this is under risk of impaired vehicle control, which can lead to accidents.
- After adjusting the steering wheel, move it up and down to back and forth to verify that it is securely locked.

Power-Assisted Steering Mode Settings

Steering Wheel Heating*

Enable steering wheel heating by any of the following methods:

1. Enable or disable steering wheel heating in the infotainment touchscreen →  → **Ventilation/Heating**.
2. Go to the drop-down shortcut menu, and tap the steering wheel heating icon. Then the setting page is displayed.
3. Voice control: activates voice control to enable or disable steering wheel heating.

Switches

Light Switches

Set the light switch to 0 to turn off all lights except for daytime running lights.

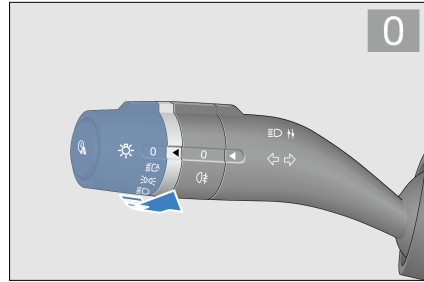

Auto lights

Set the light switch to . The body control module captures the brightness data from the light intensity sensor to automatically turn the position lights and low beam on or off.

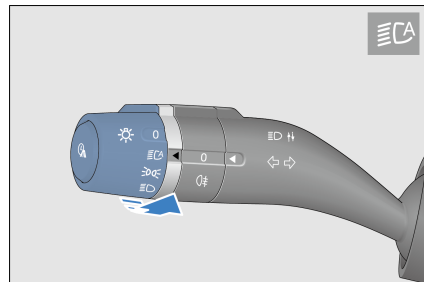

Position lights

Set the light switch to  to turn on position lights and license plate light.

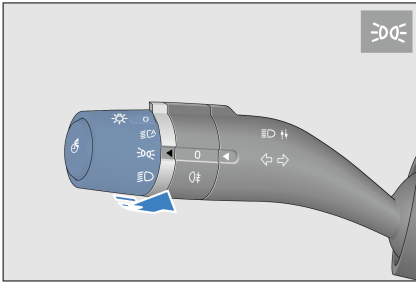

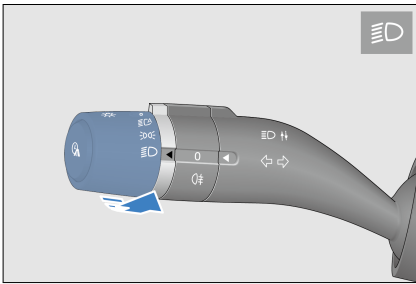

Low beam

Set the light switch to  to turn on the low beam.



Rear fog lights

Set the light switch to  and rotate the fog light dial to  to turn on rear fog lights.

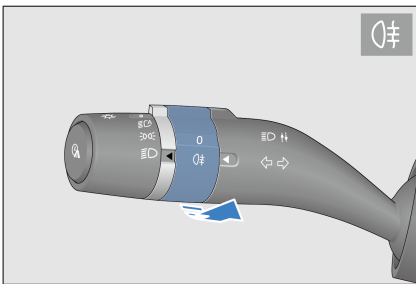

High beam

Set the light switch to  and push the lever down (away from the steering wheel) to turn on the high beam.

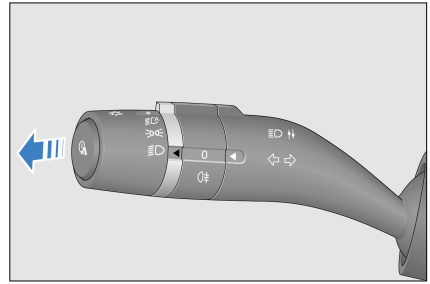

Overtaking light

Pull up the lever (toward the steering wheel) to turn on the overtaking light. Release the lever for the light switch to automatically reset. The overtaking light turns off.

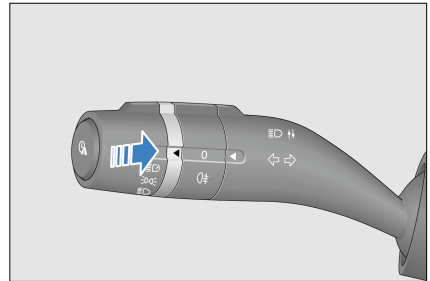

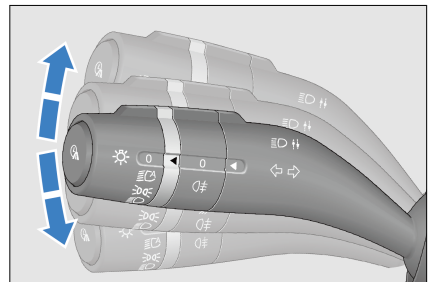

Turn signals

- Push up the lever to signal right turn. The right turn signal and its indicator on the instrument cluster flash.
- Pull down the lever to signal left turn. The left turn signal and its indicator on the instrument cluster flash.





- Once turned on, turn signals continue flashing even after the lever is released. They will turn off after the turn is complete. Depending on the driver's habit, the turn signal will reset after the vehicle turns around under some extreme conditions.

Auto light off



- Conditions to activate the auto light off function: To activate this function, set the light switch to  or  and switch off the vehicle power.
- When the function is activated, the headlights and position lights turn off in 10 seconds if the driver's door is closed.
- When the function is activated, the headlights and position lights turn off in 10 minutes if the driver's door is open.
- After the lights turn off automatically, if the light status changes, these lights come on in the new status. If the conditions to activate the auto light off function are still met, the function is activated again.
- Disabling of the auto light off function: When the vehicle is powered on, the auto light off function is disabled, and the light switch can be operated normally.
- If the auto light off function has turned off the lights and the anti-theft alarm system has been armed, when you deactivate the alarm, the lights come on again automatically. If the driver's door remains closed, the lights go off again after 10 seconds. But if any door is open, it turns off the light in 10 minutes.

Lighting delay

• Follow me home headlight:

- The lighting delay is 10 seconds by default and can be set on the infotainment touchscreen. With the light switch set to , , or , when you power off the vehicle, lock four doors, and are leaving the vehicle, the corresponding lights keep on for 10 seconds (or the set time period).

• Headlights before entering:

- The lighting delay is 10 seconds by default and can be set on the infotainment touchscreen. With the light switch set to , , or , when you unlock and are approaching the vehicle, the corresponding lights keep on for 10 seconds (or the set time period).

- You can set the delay in infotainment touchscreen →  → Vehicle Settings → Ambient Light.

Adjusting Headlight Height

When the low beam is on, on the infotainment touchscreen, tap  → Vehicle Settings → Ambient Light → Adjust headlight height to adjust the vertical height of the headlights beam.

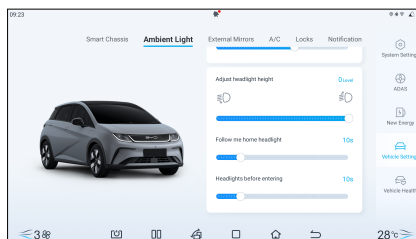





Loading Conditions	Recommended Lighting Level
One person in the driver seat	0~2
The driver and the front passenger	0~2
All the seats occupied	0~2
All the seats occupied, plus an evenly distributed load (calculated based on the technically permissible maximum laden) in the boot	1~3
Driver, plus an evenly distributed load (calculated based on the technically permissible maximum laden) in the boot	1~3

- Vehicle loading conditions may differ. Adjust accordingly.



Wiper Switches

- The lever is used to control the windscreen wipers and washer. It has five modes:

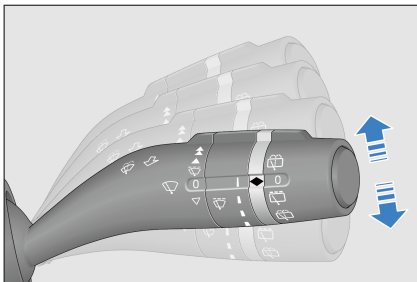
-  : Fast
-  : Slow
-  : Intermittent
-  : Off
-  : Point-wiping



- Push up or pull down the lever to select a mode.

- In slow and fast modes, the wiper operates continuously.
- Pulling down the lever from the  position activates the point-wiping mode . The wipers wipe at a low speed until you release the lever.
- The  INT knob determines the frequency at which the intermittent mode wiper operates.

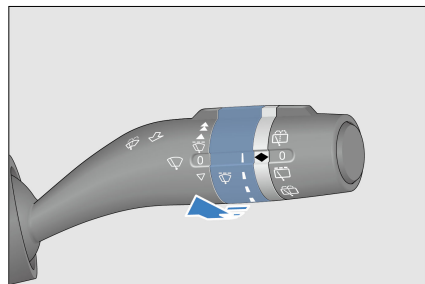

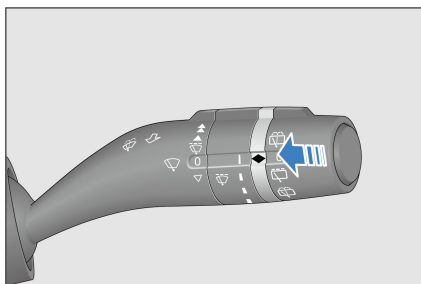

Front windscreen washer

- To clean the front windscreen, pull the wiper switch lever backward (towards the steering wheel) so that the washer spray washing fluid while the wipers operate.
- If the lever is pulled for less than one second, the wipers wipe once after the current action. If the time exceeds one second, the wipers wipe twice.



Rear windscreen wiper and washer*

- Set the wiper switch to  to activate the rear windscreen wiper; set it to  to stop the wiper.
- Set the wiper switch to  to activate the rear windscreen wiper and washer simultaneously.

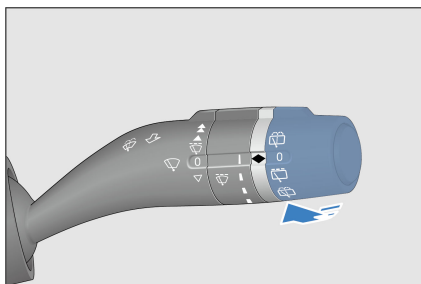

- Set the wiper switch to  and release it. The wiper operates twice after washing fluid has been sprayed.

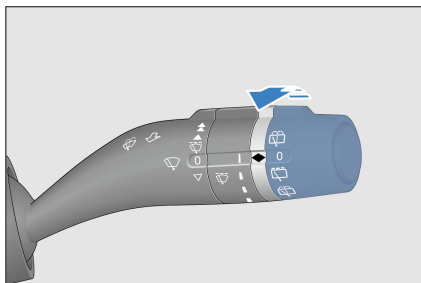

CAUTION

- Due to differences in vehicle equipment, the specific details of wiper function vary between vehicles.

REMINDER

- Check and clean the wiper blades at regular intervals.
- Do not start the wipers while rain is starting, as the windscreen cannot be cleaned and rainwater mixed with sand and dust may instantly blur your view, affecting driving safety.
- Use cleaning agent for glass. The use of water, or another type of detergent, may damage the washer motor.
- If the boot is open or not fully closed, the wiper switch will fail to control the rear wiper until the lid is closed.

Driver's Door Switches

Power Window Switches*

- When the ignition switch is on OK, all the window switches can lift up and down the window.
- Press the window switch to roll the window down.
- Pull up the window switch to roll the window up.

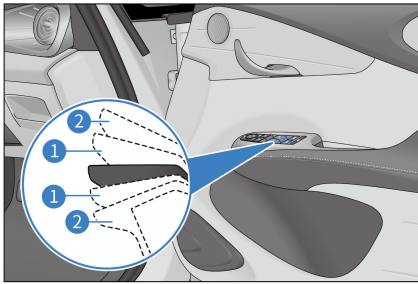

Manual operation

- Press or pull a window switch to position ① and hold to lower or raise the associated window. Release the switch to stop the window where you want it.

Auto lifting

- Press or pull a window switch to position ② and release to automatically lower or raise the associated window. During the process, operate the switch in any direction to stop raising or lowering the window.

Anti-pinch function*

If someone or an object is caught by the window when it is rolling up, the window stops and rolls down automatically.

Automatic window rolling-up and anti-pinch failure

- Taking following measures for recovery when automatic up and anti-pinch functions fail.
 - Pull up the window switch to raise the window glass to the top position and hold it there for about two seconds, and then press to lower the window glass to the bottom and hold it there for about two seconds. The automatic up and anti-pinch functions can be recovered.

Delay function

- After the vehicle is powered off, if the front doors are not open, the four window switches has a 10-minute roll-up/down delay period. During this period, the windows can still be rolled up and down. If either of the front doors is opened during this period, the delay function is cancelled, and the switches can no longer be used to operate the windows.

WARNING

- Never try to deliberately activate the anti-pinch function.
- Please follow the precautions below to prevent serious injury or death from window closing:
 - Before operating the power windows, ensure that all passengers do not have any body parts that can be caught in the window.
 - Do not allow a child to operate the power windows.

CAUTION

- The anti-pinch function may not work if an object is jammed into the window when it is almost completely closed.
- Contacting a BYD authorised dealer or service provider for maintenance is recommended if the windows' automatic closing function or anti-pinch function is not working normally.

Window Lock Switch

Press the window lock switch. The red window lock indicator goes on. Only the switches on the driver's side can be used to open/close four windows; the window switches on the rear row are deactivated.

Press the switch a second time. The red window lock indicator goes out, and the window switches on the rear row work normally.

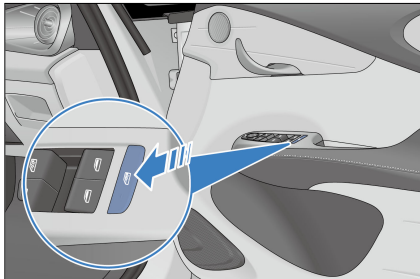

Central Locking

The driver's door is equipped with power door lock switches to lock or unlock all doors.

Locking

Press the central lock button. All doors are locked and the red lock indicator lights up.

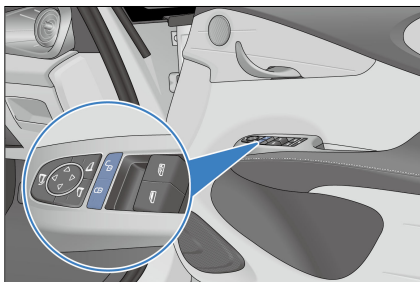

Unlocking

Press the central unlock button. All doors are unlocked and the red lock indicator turns off.

Side Windows

Passenger's Window Switches

When the ignition is on or off (during the delay function timing period), the passenger's window switches can be used to roll the associated window up or down.

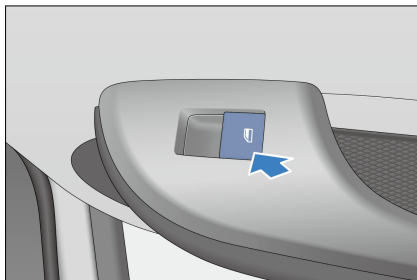

Odometer Switch

Press the odometer switch to switch between "Total Mileage" - "Mileage 1" - "Mileage 2" - "Total Mileage". The switching status is displayed accordingly on the instrument cluster.

Press and hold "Mileage 1" and "Mileage 2" to clear the mileage information.

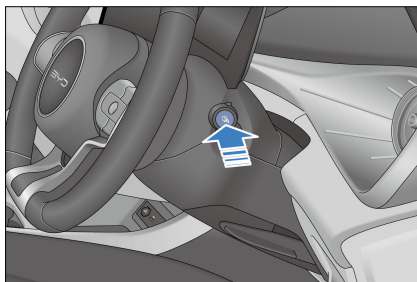

Driver Assistance Switches

Mode switches

Scroll the roller up or down to switch between NORMAL, ECO, and SPORT modes.

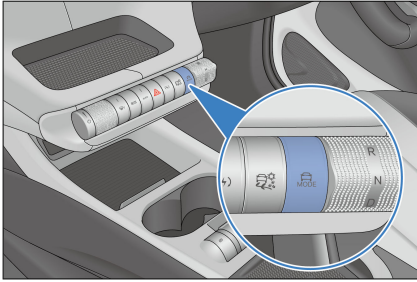

- Ecology, Conservation, Optimization (ECO): moderate vehicle power, comfortable driving and riding experience, and better economy.
- Normal (NORMAL): standard settings mode, the default driving condition.
- Sport (SPORT): The vehicle shows good power performance, but its acceleration performance is reduced at low SOC, or too high or low temperatures.

Snow mode switch

- Roll the scroll button up/ down to enter/exit the snow mode.
- This mode is recommended on fairly strong surfaces that are covered with a layer of loose and slippery materials (e.g., grass, snow, ice, or gravel).

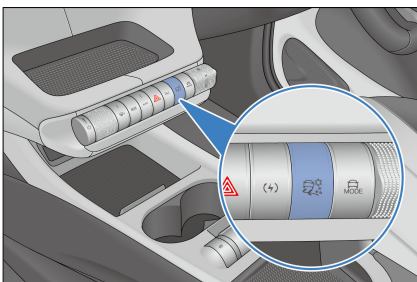

- Snow mode optimizes the towing, driving, and manipulation features in slippery conditions, and the accelerator pedal is selected with caution.

CAUTION

- ESC system may limit the vehicle's torque. Therefore, temporarily shutting down the system may help if the vehicle skids and gets stuck in soft snow. The ESC system must be restarted after conditions are back to normal (See **P131**).

Regenerative braking button



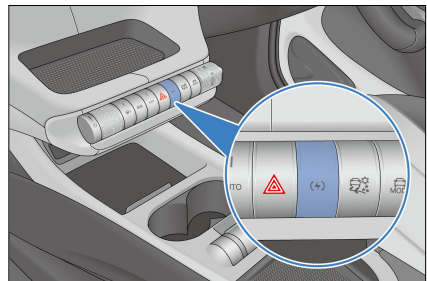

Scroll the roller up or down to switch between standard and high regenerative braking modes.

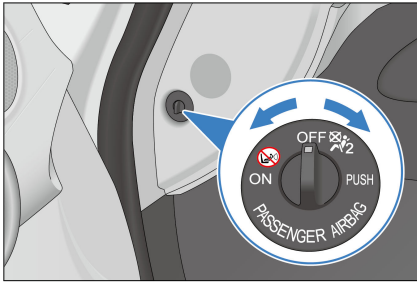

Passenger Airbag Switch

- The front passenger airbag can be deactivated if the car is equipped with a passenger airbag switch.
- The switch is located on the passenger side of the dashboard and is accessible when the passenger's door is open.



- The front passenger airbag indicator is located on the ceiling.
- Check that the switch is in the required position.
- Enable or disable the front passenger airbag according to the use of the front passenger seat:
 - When the switch is ON, the front passenger airbag is activated. The front passenger airbag indicator "PASSENGER AIRBAG" is solid on, "ON" and  come on, and "OFF" and  are off. The front passenger airbag deploys in the event of a moderate to severe collision that meets the necessary deployment conditions.
 - When the switch is OFF, the front passenger airbag is deactivated. The passenger airbag indicator "PASSENGER AIRBAG" is solid on, "ON" and  are off, and "OFF" and  come on. The front passenger airbag do not deploys in the event of a moderate to severe collision that meets the necessary deployment conditions.

WARNING

- Never use a rear-facing child restraint on the front passenger

WARNING

seat with an activated passenger airbag. Failure to do so can result in serious personal injury or death.

- When the front passenger seat is occupied with an adult, the passenger airbag switch must be turned to "ON" to always keep the front passenger airbag active.
- If the front passenger airbag remains active when the passenger airbag switch is off, immediately contact a BYD authorised dealer or service provider.

CAUTION

- To prevent damage to the airbag system, only operate the passenger airbag switch when the ignition is switched off.
- It is the driver's responsibility to confirm that the passenger airbag switch is in the correct position for the person sitting in the front passenger seat.

Emergency Call (E-Call)

- ① E-Call status indicator
- ② SOS button

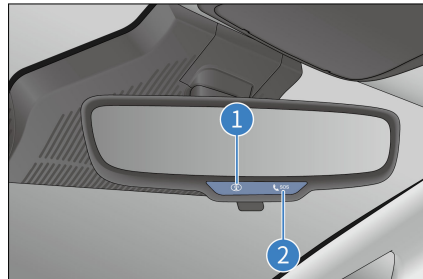



- E-Call refers to emergency call. Pressing and holding the SOS button for 1 second $\leq t \leq 10$ seconds triggers the E-Call system manually, and pressing and holding the button for 10-20 seconds does not.
- To cancel an emergency call made by mistake, press the SOS button a second time within five seconds.
- The E-Call system activates automatically in the event of airbag deployment or the detection of a severe collision.
- When triggered, the system automatically makes an emergency call and communicates standard information to a public safety answering point.

CAUTION

- The SOS button will be considered to be short-circuited (button stuck) if you press and hold the SOS button for over 20 seconds. In that case, the E-Call cannot be triggered manually.
- The dialed emergency call cannot be cancelled manually. The E-Call system will begin 60-minute callback time after the call is hung up by the public safety answering point or is not answered when it has been dialed 10 consecutive times.

Status	LED indicator	Beeping
Ignition off or E-Call system failure	Off	\
Power-on self-check mode	Flashing fast - 2 Hz	\
Ignition on and self-check passed	Solid on if self-check is passed	\
E-Call connecting	Flashing - 1 Hz	A beep
E-Call connected	Flashing - 1 Hz	A beep
E-Call ended	Solid on	Two beeps after E-Call ends
Callback time (60 minutes by default)	Flashing extremely slowly - 0.2 Hz	\

Hazard Warning Light Switch

Scroll the wheel  up and down once. All the turn signals and their indicators start to flash. Scroll  up or down once again to stop the flashing.

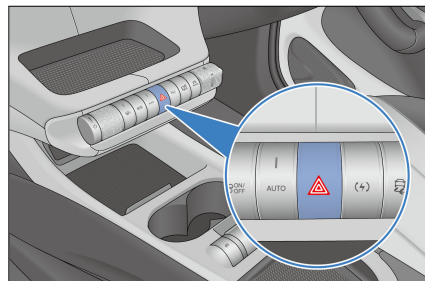

Sunshade*

Opening the sunshade

- Press and hold the sunshade open button ① to open the sunshade manually. Release the button midway to stop the sunshade.
- Release the sunshade open button ① immediately after touching it. The sunshade opens automatically. For the sunshade to stop at its current position, touch the ① or ② button midway.

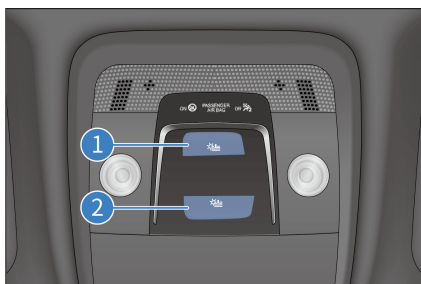

Closing the sunshade

- Press and hold the sunshade close button ② to close the sunshade manually. Release the button midway to stop the sunshade at its current position.
- If the sunshade has been initialised, releasing the sunshade close button ② immediately after touching it closes the sunshade automatically. For the sunshade to stop at its current position, touch the ① or button ② midway.

WARNING

- Keep clear of the sunshade when it is opening or closing, or severe injury may occur.
- When opening or closing the sunroof sunshade, avoid forceful

WARNING

contact with its curtain, to prevent damage.

Initialisation

when the sunshade operating system fails, in order to maintain the anti-pinch function, it may not able to be opened or closed by pressing the button. In this case, initialize the settings as follows:

- Press and hold the sunshade close button so that the sunshade moves to the end and release your hand after hearing a sound of sunshade motor stalling.

CAUTION

- If Initialization dose not work, contact a BYD authorised dealer or service provider.

Interior Light Switch

In any ignition status, touch the cover of front interior lights to turn on the lights.

Configuration 1

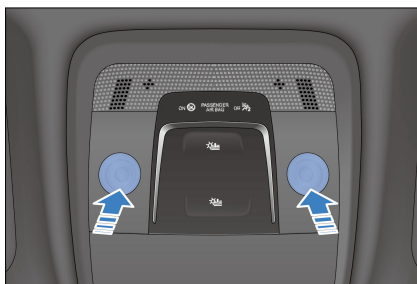

Configuration 2

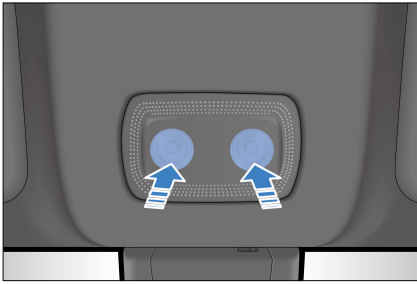

! REMINDER

- In any ignition status, while DOOR option is selected and any door is open, interior lighting switches between high and low brightness with touches on the light switch.
- With the ignition off and DOOR option selected, interior lights will go off after the door have remained open for a period of time.

04

USING AND DRIVING

Charging/Discharging Instructions	72
Battery.....	86
Usage Precautions.....	90
Starting and Driving.....	96
Driver Assistance.....	104
Other Main Functions.....	135

Charging/ Discharging Instructions

Charging Instructions

- Charging equipment uses high-voltage current. Minors are prohibited to charge the vehicle or touch the charging equipment. Keep them away from the vehicle during charging.
- Charging may affect medical or implanted electronic devices. Consult the device manufacturer before charging.
- Charge the vehicle in a relatively safe environment, and avoid charging in damp areas, or areas with fire or heat sources.
 - Protect the charging equipment against water contact on rainy days.
- Before charging:
 - Ensure that power supply equipment, charging connector, charge port, and charging connection device are free of defects, such as cable wear, rusted ports, cracked casings, or foreign objects in the ports.
 - Do not charge the vehicle when the charging connector's or port's plug, socket, or metal terminals are loose or damaged by rust or corrosion.
 - When the charging connector, port, power plug, or socket is visibly stained or damp, wipe them with a dry and clean cloth to ensure the connection is dry and clean.
- Use charging equipment that complies with local standards.
- To avoid charging failure or fire, do not modify, disassemble, or repair the charging equipment and related ports. Contact a BYD authorized dealer or service provider for handling if there is a fault.
- Do not use charging equipment that does not meet safety standards or has potential safety hazards. Do not allow children to use the charging equipment and keep animals away from the vehicle while charging.
- Ensure that your hands are properly dry before charging.
- If anything abnormal is found in the vehicle or charging equipment during charging, stop immediately and contact a BYD authorised dealer or service provider.
- Always observe the following charging precautions to prevent damage to the vehicle:
 - Do not shake the charging connector, otherwise the vehicle charge port may be damaged.
 - Whenever possible, do not charge the vehicle in a thunderstorm, under risk of lightning strikes.
 - Do not open the bonnet for maintenance while charging.
 - After charging, do not disconnect the charging equipment with wet hands or while standing on any wet surface.
 - Before driving, ensure that the charging equipment is disconnected from the charge port.

Compatibility of Vehicle and Charging Infrastructure

- The signs are located on the vehicle's charging socket, components of the local charging infrastructure (charging stations and sockets) and on the charging cable.

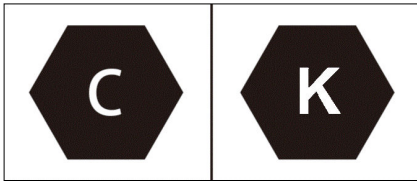

- The signs refer to standardised charging systems in accordance with DIN EN 62196.

Charging Precautions

- When the SOC bar on the instrument cluster turns red, the high-voltage battery is about to be exhausted. Please charge it immediately, otherwise the service life of the high-voltage battery will be reduced.
- Mode 2 charging means charging with an AC charging connector that complies with local standards. Use a dedicated AC line and power outlet that meets local standards. The purpose of using a dedicated line is to protect the line from tripping due to line breakage or high-power charging of the high-voltage battery. Using a line other than dedicated lines may affect proper operation of other devices on the line.
- Avoiding damage to the charging equipment (precautions for charging equipment):
 - Prevent the charging equipment from suffering any mechanical impact.
 - Do not place the charging equipment near heaters or other heat sources.
 - Never drop the equipment or move it by pulling it directly by the cable. Take caution when moving the equipment.
- Inserting the charging connector before charging:
 - Make sure that the charging connector and charge port are free of foreign objects, and that the protective cap of the charging connector terminal does not get loose or deformed.
 - Hold the charging connector, align the connector with the charge port and push it in, making sure that they are properly connected.
- When charging is complete:
 - Stop charging first and make sure the charge port is unlocked.
 - Pull the charging connector.
 - Do not force the charging connector out while the charge port is locked, otherwise the charge port may be damaged.
- Precautions:
 - The A/C can be used as normal while the vehicle is being charged. To ensure the charging power, it is recommended not to turn on the A/C.
 - It is recommended that no one stay in the vehicle during charging.
 - It is recommended to park the vehicle in a ventilated area during charging.
 - The vehicle system automatically stops charging when the high-voltage battery is fully charged. The charge port is equipped with an electronic lock. Unlock it before unplugging the charging equipment.
 - To stop DC charging, turn off the charger before disconnecting the charging connector. In Mode 2 charging, remove the charging connector and then the power plug.
 - When charging is complete and the charging connector is unplugged, make sure that the charge port's cap and door are closed, otherwise water

or foreign materials may enter the port and affect its normal use.

- Before starting the vehicle, ensure that the charging equipment is disconnected. The locking mechanism can damage the charging equipment and the vehicle if the vehicle is started with the charging connector incorrectly inserted.
- Battery temperatures that are too low or too high can compromise vehicle charging performance.
 - The temperature control system can improve low-temperature charging capacity of the battery. Due to output capacity limitations of charging piles, the charging time is extended, the heating time becomes longer and the power consumption of heating is increased. These are normal phenomena.
 - For faster low-temperature DC charging, charging from low SOC is recommended because, due to the low battery temperature, the charging current is small for vehicles with high SOC in low-temperature environments.
 - To improve your experience, it is recommended to charge the vehicle immediately after using it, as the battery is relatively hot and has better charging performance.
- Turning A/C on during low-temperature charging affects the performance of battery temperature control system and charging performance.
- It is normal that when the battery temperature control system is working during charging, the charging power displayed on the instrument cluster may fluctuate temporarily.
- Before charging is complete, battery equalisation is activated for longer

battery life and thus the charging time may be longer.

- In case of high-temperature high-power DC charging, the performance of battery temperature control system may be affected by the A/C in the passenger compartment, and the charging performance may degrade, resulting in an extended charging time. To ensure charging efficiency, it is recommended to keep the A/C off during charging.
- When the heating or cooling function is enabled during charging, it is normal that both charging time and power consumption increase slightly.
- During charging, battery cooling may start, and the compressor, fan and other components work when necessary. It is normal that there will be some noise under the bonnet.
- During charging, the estimated remaining time to full charge is displayed on the instrument cluster. It is normal that the remaining time to full charge may vary slightly, depending on the temperatures, SOC, and charging facilities.
- If the charge port door is frozen due to weather or other reasons, do not force it open.
- If the battery has not been fully charged for a long time, the instrument cluster may prompt a message showing "Please charge the vehicle to full capacity to allow the battery to balance automatically." It is recommended to fully charge the vehicle as soon as possible to ensure the lifespan of the battery.



REMINDER

- If the charging connector cannot be removed after unlocking,

**REMINDER**

try a few more unlocking attempts. If that does not work, try emergency unlocking. For the operating procedure, see "Emergency Unlocking of the Charge Port" in "Charge Port Anti-theft Lock".

**REMINDER**

- To unlock the charge port after DC charging, press the unlock button twice within three seconds for the operation to be successful.
- See the charging instructions for specific charging precautions.

General Charging Troubleshooting

Fault	Possible Cause	Solution
Charger is connected, charge starts, but battery will not charge.	The high-voltage battery has been fully charged.	When the high-voltage battery is fully charged, the charging stops automatically.
	High-voltage battery temperature is too high or too low	Keep the vehicle in an environment with appropriate temperature and charge it when the temperature becomes normal.
	Low-voltage battery over-discharges.	Replace the low-voltage battery.
	Charging equipment fails.	If it is verified that the charging equipment's power indicator is working properly, or that there are no other unusual indications, change the charging equipment or contact the charging equipment supplier.
	Vehicle display fails.	Verify that there is a charging system fault message on the instrument cluster, then stop the charging. It is recommended to contact a BYD authorised dealer or service provider.
Charging stops midway.	AC grid outage	Charging will automatically restart when the power grid is restored.
	Charging cable is not connected properly.	Verify that the charging connection cable is not loosely connected.
	Charging connection switch is pressed.	If the charging connection switch is pressed, the charging will stop. The charging connection should be connected again to start charging.
	High-voltage battery temperature is too high.	Charging stops automatically if the high-voltage battery overheating warning light comes on on the instrument cluster. Charge the vehicle when the battery temperature returns to a normal level.

Fault	Possible Cause	Solution
	Vehicle or charging pile fails.	If there is any fault prompt for the charging pile or the vehicle, it is recommended to contact a BYD authorised dealer or service provider.

Charging

- Before charging:
 - Ensure that power supply equipment, charging connector, charge port, and charging connection device are free of defects, such as cable wear, rusted ports, cracked casings, or foreign objects in the ports.
 - Do not charge the vehicle when the charging connector's or port's plug, socket, or metal terminals are loose or damaged by rust, corrosion or erosion.
 - When the charging connector, port, power plug, or socket is visibly stained or damp, wipe them with a dry and clean cloth to ensure the connection is dry and clean.
- Do not charge in any of these cases. Otherwise, personal injury may occur due to short circuit or electric shock.

Using Mode 2 Charging Cable*

Before Using Mode 2 Charging Cable

- To prevent serious personal injury, see Charging Safety Warnings in "Charging Instructions" carefully.
- To prevent damage to the charging equipment and the vehicle, see Charging Precautions in "Charging Instructions" carefully.

Equipment

- Connect the vehicle to an outlet that meets local standards to charge the vehicle.
- A household socket meeting local standards must be used in order to avoid line damage or tripping due to high-power charging, which may effect the normal use of other devices.
- This Mode 2 charging cable includes a power plug (complying with local standards), a charging connector, a control box, and a charging cable*. The plug is connected to a standard household power socket, and the charging connector to the vehicle's charge port.
- Charging time: Refer to the charging time message on the instrument cluster.



WARNING

- See "Charging Instructions" for charging safety warnings.
- The highest working temperature allowed for the product is 122°F (50°C). Store the product in a cool and dry place when it is not in use.
- When charging, do not place the equipment in the boot, under the front of the vehicle, or near the tyres.
- When using the equipment, prevent it from getting rolled over by the vehicle, dropped, or trampled on.
- It is not recommended to use any additional wire or adapter/

WARNING

connector. If an additional adapter is required, choose a suitable cable diameter (≥ 0.0023 in² or ≥ 1.5 mm²) and the adapter/connector parameters must meet requirements.

- Never use the charging equipment if the household power strip cable becomes soft, if the charging connector cable is worn out, if the insulation layer is cracked, or in case of any other damage.
- Never use the equipment when the charging connector, power plug, or power strip is disconnected or broken, or if there is any sign of surface damage.

CAUTION

- The charging cable must not be placed in a spiral during charging, as this will affect heat dissipation.
- See **P73** for specific charging precautions.
- To prevent failure of the charge port door, do not open and close it repeatedly. The recommended time interval for opening and closing the port door is at least one second.

REMINDER

- It is recommended to contact a BYD authorised dealer or service provider or local electrician to select an appropriate power supply according to requirements of the charging equipment.
- Charging equipment grounding instructions: The equipment must

REMINDER

be properly grounded. In the event of failure or damage to the equipment, the grounding cable provides a minimum impedance to circuit discharge and thereby reducing the risk of electric shock.

- The power plug must match a properly installed and well-grounded power supply outlet.

Charging

1. Open the charge port door

- With the vehicle doors unlocked and preferably powered off, press the charge port door to open it.



2. Open the charge port cap

- Open the charge port cap, and make sure that no obstacles exist between the head of the charging connector and the end of the charging socket.

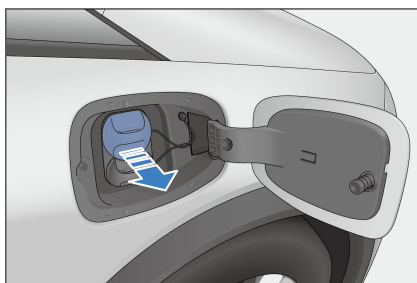

REMINDER

- Do not open the charge port door forcibly when it is locked.
- If the charge port door is frozen due to weather or other reasons, do not force it open.

3. Connect the power supply terminal

- Plug the Mode 2 charging cable* into a household socket.

4. Connect the vehicle port

- Plug the charging connector correctly into the port.
- After the charging connector is inserted, the charging connection indicator  lights up on the instrument cluster.

REMINDER

- Do not forcibly insert the connector with the electric lock engaged.
- In the charging process, charging parameters and the charging sign are displayed on the instrument cluster.
- At this point, you can schedule charging on the Infotainment system. See "Charging Reservation" for the setup process.

REMINDER

- During charging, the estimated remaining time to full charge is displayed on the instrument cluster. It is normal that the remaining time to full charge may vary slightly, depending on the temperatures, SOC, and charging facilities.

REMINDER

- Reservation charging cannot be used when the battery is too low.

Stopping charging

1. End the charging

- The charging automatically ends when the vehicle is fully charged.

2. Unplug the charging connector

- Press the unlock button on the smart key or press the door handle microswitch while carrying the smart key and pull out the charging connector.

CAUTION

- To unlock the vehicle, press the unlock button on the key (when charging the vehicle with ignition switched off) or press the microswitch on the door handle (when the key is nearby).
- Unlock the vehicle to deactivate the anti-theft lock before pulling out the charging connector. The connector has to be pulled out within 30 seconds, or the port will relock.
- You can activate the anti-theft lock on the infotainment touchscreen, as detailed in **P84** in this chapter.
- If the charging connector cannot be removed after unlocking, try a few more unlocking attempts. If that does not work, try emergency unlocking. For the operating procedure, see **P84**.
- When the charge port's anti-theft mode is deactivated, if you cannot pull the charging connector out



CAUTION

directly, try to unlock the vehicle and pull it again.

3. Disconnect the power plug.

4. Close the charge port cap and the port door.

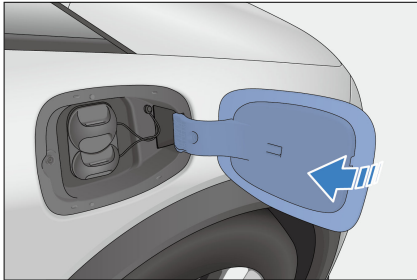

5. Store the charging equipment properly.



REMINDER

- Do not close the charge port door when the port cap is fully open.

Using AC Charging Piles

Before Charging with AC Charging Piles

- To prevent serious personal injury, see Charging Safety Warnings in "Charging Instructions" carefully.
- To prevent damage to the charging equipment and the vehicle, see Charging Precautions in "Charging Instructions" carefully.

Equipment

- AC charging box *
 - Use a standard-compliant household charging box. For how to use the charging equipment, refer to its user manual and follow the operating steps.

- AC charging box: consists of a charging box, a charging connector, and a connecting cable. For information on circuit breaker and emergency stop switch, see the charging box user manual.

AC charging pile

- Charge the vehicle using an AC charging pile in a public place. Charging time: Refer to the charging time message on the instrument cluster.

Charging

1. Open the charge port door

- Close the charge port cap and the port door (See instructions for mode 2 charging).

2. Connect the vehicle port

- Plug the charging connector into the port and make sure it is tight.

3. Charging settings

- For AC charging pile/box subject to authentication, swipe the card or scan the QR code. See the user manual for charging pile/box for details.

4. The charging connection indicator  lights up on the instrument cluster.



REMINDER

- In the charging process, the instrument cluster displays relevant charging parameters and the charging sign.

Stopping charging

1. End the charging

- Charging ends automatically when early stop time is due or charging is complete.

2. Unplug the charging connector

- Disconnect as per the instructions for mode 2 charging.

3. Close the AC charge port door (see instructions for mode 2 charging).

4. Store the equipment properly.

- If using an AC charging pile/box, place the charging connector in its designated location in the charging pile/box.

Using DC Charging Piles

Before Using DC Charging Piles

- To prevent serious personal injury, see Charging Safety Warnings in "Charging Instructions" carefully.
- To prevent damage to the charging equipment and the vehicle, see Charging Precautions in "Charging Instructions" carefully.

Equipment

- Charge the vehicle using a DC charging pile in a public place, which is typically installed at a specific charging station.
- Charging time: Refer to the charging time message on the instrument cluster.
- Equipment specifications: Please check the instructions for the charger.

Charging

DC charging is achieved by connecting the vehicle to a DC charger via its connector.

1. Open the charge port door

- Unlock the charge port door, then open the port door and cap.

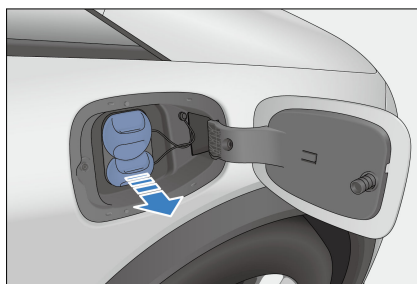

2. Connect the vehicle port

- Plug the charging connector into the port and lock it.

3. Operate the charging equipment to start charging.

4. The charging connection indicator  lights up on the instrument cluster.



REMINDER

- In the charging process, the instrument cluster displays relevant charging parameters and the charging sign.

Stopping charging

1. End the charging

- Charging ends automatically when early stop time is due or the charging is complete.

2. Unplug the charging connector

- Remove the charging connector.
- Press the unlock button twice within three seconds or press the microswitch on the door handle to stop charging.

3. Close the DC charge port cap and the port door.

4. Store the equipment properly

- When the DC charging pile charging is complete, organise the charging equipment and store the charging

connector in its designated position properly.

WARNING

- See section "Charging Instructions" for charging safety warnings.

CAUTION

- If the charging connector cannot be removed after unlocking, try a few more unlocking attempts. If that does not work, try emergency unlocking. For the operating procedure, see "Emergency Unlocking of the Charge Port" in "Charge Port Anti-theft Lock".
- To unlock the charge port after DC charging, press the unlock button twice within three seconds for the operation to be successful.
- See the charging instructions for specific charging precautions.

REMINDER

- Do not close the charge port door when the port cap is fully open.

Intelligent Charging

- This model is provided with the intelligent charging function. It is not necessary to disconnect the low-voltage battery's negative terminal when the vehicle is to be parked for a long period.
- When the left body control module detects that the low-voltage battery is too low, the low-voltage battery may be charged by the high-voltage battery.



REMINDER

- When the vehicle is stored for a long time, the intelligent charging function may be activated, which is normal and not a vehicle failure.
- Power for intelligent charging comes from the high-voltage battery pack, so it is normal that an SOC decrease is noticed when the vehicle is powered on.
- To avoid high-voltage battery over-discharging due to intelligent charging, when the vehicle is at low SOC, intelligent charging is not available. Avoid parking at low SOC for a long time, and charge the vehicle in time.

Smart Charging

- Smart charging encompasses the feature of scheduled charging and scheduled departure*. Scheduled charging allows you to customize the daily start time of the charging session. Scheduled departure enables you to set a desired departure time, before which the vehicle is fully charged, and if needed, the cabin temperature is optimized and the battery is preheated.
- You can access the setting screen either through the infotainment system or voice control:
 - You can access this function by touching the app Smart Charging on the infotainment system.
 - On the infotainment touchscreen, tap  → **Energy** → **Charging Settings** to go to the Smart Charging screen.
 - Say "Hi BYD, start smart charging/scheduled charging/scheduled departure", "Hi BYD, I want to make smart charging/scheduled

charging/scheduled departure” , or "Hi BYD, please help me start smart charging/scheduled charging/scheduled departure".

- To exit the setting screen:
 - tap  or  .
 - Say "Hi BYD, end smart charging/scheduled charging/scheduled departure" or "Hi BYD, exit smart charging/scheduled charging/scheduled departure".

REMINDER

- Scheduled charging and scheduled departure can not be activated simultaneously.

Scheduled Charging

- ① Scheduled charging switch
 - ② Scheduled Charging
 - ③ Repeat cycle
 - ④ Switch to scheduled departure
 - ⑤ Settings
- The factory default setting is to charge the vehicle immediately. That is, scheduled charging is disabled.
 - To schedule a charging, toggle the scheduled charging ON ①, set the charging start time ② and repeat cycle ③, then save the settings.
 - After the reservation is set up successfully, if you connect the charging connector or press the power button to power off the vehicle during the charge waiting period, you will be reminded through the infotainment touchscreen that scheduled charging has been set. Switch to instant charging if needed.
 - You can tap the scheduled charging setting icon ⑤ to turn off the charging

connector connected alert and power-off alert in the Reservation Charging Alert.

- Tap  to switch to scheduled departure.

CAUTION

- The reservation charging function is developed for BYD's slow AC charging equipment only. Please disable this function when using slow AC charging equipment that is not certified by BYD. Otherwise, scheduled or immediate charging may fail due to no response from the equipment, resulting in low SOC or even low voltage of the high-voltage battery.

REMINDER

- The vehicle's power will increase while waiting for the scheduled charging. It is normal for long waiting to result in a reduction of the vehicle's power and driving range.
- The instant charging option on the reminder screen is valid for the current reservation only. To cancel all reservations, turn charging reservation off on the reservation setting screen.
- In the event of low battery, the vehicle is charged to the minimum level before scheduled charging begins. In this process, the infotainment system still gives reminder messages for power-off and charging connector connection, and a related message is displayed at the lower part of the instrument cluster.
- The schedule setting is invalid for DC charging. Charging begins



REMINDER

immediately after a DC charging connector* is connected.

Scheduled departure

- ① Scheduled departure switch
 - ② Scheduled departure time
 - ③ Repeat cycle
 - ④ Concessionary tariff hours
 - ⑤ Switch to scheduled charging
- To schedule a charging for departure, toggle the switch ① on, set the intended departure time ②, choose from single-use, daily, or customized repeat cycle options at ③, fill out the concessionary tariff hours ④, and save the settings.
 - The system optimizes charging by utilizing off-peak hours, ensuring it completes charging when the power price is lower. If the remaining charging time is longer than the remaining travel duration or the concessionary tariff hours, the vehicle initiates immediate charging to maximize the amount of energy it can acquire.
 - The preheating function ensures the battery performs well in low temperature conditions, ready for optimal performance.
 - The intelligent cabin temperature control pre-cools or warms the cabin, ahead of the scheduled departure, ensuring a cozy environment.
 - Tap ⑤ to switch to scheduled charging.



CAUTION

- When the SOC reaches a critically low level, the vehicle is charged



CAUTION

- to a minimum level before scheduled charging begins.
- Ensuring full charge, if not complete after the concessionary tariff hours, the vehicle continues charging until it is fully charged.
- When the vehicle is powered on, low-temperature battery preheating and cabin temperature control are deactivated, but the concessionary tariff hours are still in effect.
- If the current time exceeds the scheduled departure time, both battery preheating and cabin temperature control are deactivated.
- Battery preheating and cabin temperature control incur a temporary battery usage.
- Battery preheating and cabin temperature control are only available when the SOC is above 40%.
- The vehicle's power will increase while waiting for the scheduled charging. It is normal for long waiting to result in a reduction of the vehicle's power and driving range.
- The scheduled charging function is only developed for slow AC charging equipment supplied by BYD. Please disable this function when using slow AC charging equipment that is not certified by BYD. Otherwise, scheduled or immediate charging may fail due to no response from the equipment, resulting in insufficient battery power or even lack of electricity.

Charge Port Anti-theft Lock

In order to prevent the charging connector from being stolen, the charge port of this vehicle is anti-theft during charging and discharging. The anti-theft function is disabled by default. To enable the function, go to the infotainment touchscreen →  → **New Energy** → **Charging Settings** and then tap **Activate**.

- When the function is enabled, unlock the vehicle and unplug the charging connector during charging in the following ways:
 - Press the unlock button on the smart key to unlock.
 - Press the microswitch next to the exterior handle of the driver's side door to unlock.

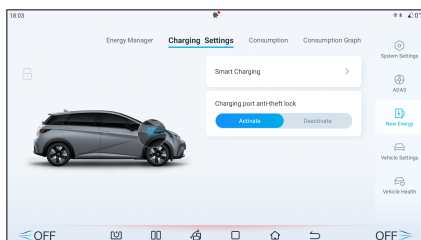

- Press the central unlock button under the driver's window to unlock.

CAUTION

- Unplug the charging connector in 30 seconds after unlocking or it will be locked again.
- When the anti-theft mode is disabled, the electrical lock of the charge port automatically releases once the charging is stopped. When the anti-theft mode is enabled, the vehicle needs to be unlocked first.

Emergency Unlocking of the Charge Port

- When charging connector cannot be unplugged due to failure of the anti-theft lock, unlock the charge port manually.
- Open the bonnet. A lock latch can be found inside. Pull the latch to unlock the charging connector.

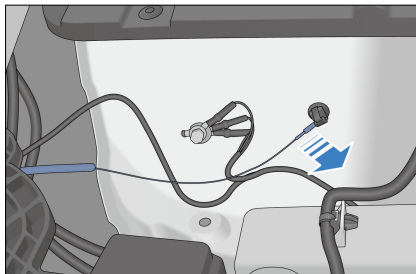

REMINDER

- In the event of abnormality or function failure, contact a BYD authorised dealer or service provider.

External Discharging

This vehicle is equipped with vehicle to load feature.

WARNING

- Do not touch any metal terminal of the discharging socket or vehicle charge port during discharging.
- Stop discharging immediately if there are any abnormalities such as peculiar smell and smoke.
- See **P72** for charging safety warnings.

WARNING

- Store the product in a cool and dry place when it is not in use.
- When discharging, do not place the equipment in the boot, under the front of the vehicle, or near the tyres to prevent it from getting rolled over by the vehicle, dropped, or trampled on.
- When using the equipment, prevent it from getting rolled over by the vehicle, dropped, or trampled on.
- Never use the equipment when the discharging connector or power strip is disconnected or broken, or when there is any sign of surface damage.

CAUTION

- For precautions concerning use of the discharge connection device*, please refer to precautions for charging equipment in "Charging Precautions".
- Before discharging, please confirm the vehicle SOC and estimate the remaining driving range.
- Before V2L discharging, ensure that the load is turned off.

REMINDER

- The VTOL function is recommended only when State of Charge (SOC) is high.
- The VTOL function is restricted when the vehicle SOC is low.

External Discharging

Starting Discharging

- Before discharging, disarm the anti-theft alarm system.
- Unlock the charge port door switch, then open the port door and cap.
- Check before discharging:
 - Ensure that the battery capacity of the vehicle to be discharged is not below 15%.
 - Ensure the V2L connection device casing is not cracked, and its plug is free from rust or obstructions.
 - Ensure that there is no water or foreign material inside the charge port and that metal terminals are not damaged and free from rust or corrosion.
 - Do not discharge if abnormalities as described in the second or third condition are found; otherwise, short circuit or electric shock so caused could lead to personal injury.
- Connect the discharge connection device:
 - Connect the V2L discharge device to the charge port. The power strip indicator lights up when the strip is powered and ready for use.
- Discharging starts:
 - After the connection is made, discharging begins and respective information is displayed on the instrument cluster.

Stopping discharging

- Stop discharging:
 - Disconnect the load.
- Disconnect the discharge connection device:

- Unplug the discharging device.
- Close the charge port cap and the port door (see instructions for Mode 2 charging).
- Organising the equipment:
 - Store the equipment properly when discharging is complete.

Battery

High-Voltage Battery

- The vehicle is powered by a high-voltage battery that can be charged and discharged repeatedly. The high-voltage battery is charged by an external power source or through energy recovery when the vehicle brakes or coasts.
- The high-voltage battery is located under the vehicle floor, so be careful to avoid bumping when driving on bumpy or uneven roads.
- Due to the chemical characteristics of the battery itself, the battery capacity of vehicles that have been used for a period of time has natural degradation, and their pure electric mileage will reduce. It is recommended to go to a BYD authorized dealer or service provider for regular vehicle checks. The store-side inspection can confirm whether the reduction of pure electric mileage is normal.
- When SOC is high, the regenerative braking performance may decline.
- The vehicle switches to trickle charging mode at high SOC. If the charging time is prolonged, the estimated remaining charging time displayed on the instrument cluster may not be accurate.
- When SOC is low, the acceleration performance may decline.
- When the high-voltage battery is low, V2L cannot be used as normal. Charge the battery promptly.
- At high or low temperatures, it is normal that the charging and discharging capabilities of the high-voltage battery decline, and the charging time is prolonged. Power performance may also decline under extreme temperatures.
- When charging in low temperatures, the temperature control system can significantly improve charging capability. For details, see Charging Precautions.
- When the vehicle is used at low temperatures, the battery's temperature control system will start heating the battery as appropriate to ensure the driving power and discharging performance and improve your driving experience. When the vehicle is driven over short distances, heating may be ineffective, which increases power consumption and decreases driving range.
- When the high-voltage battery is normal, the driving range of the vehicle varies with the following factors:
 - Driving habit: For example, the range in frequent acceleration or deceleration is shorter than that at constant speeds, and the range is shorter when driving at high speeds than when at low speeds.

Battery Properties

- It is normal that vehicle performance is affected by battery electrochemical properties and self-protection and varies to some extent in the following conditions:

- Road conditions: For example, the range driven in rough conditions or on long slopes is shorter than that in normal conditions and on even roads.
- Temperature: The driving range at low temperatures is shorter than that at ambient temperatures.
- Use of electric equipment: For example, the range driven with A/C on is shorter than that with A/C off.
- Usable capacity of the high-voltage battery is lower in cold weather and reduces as the temperature decreases. If the vehicle with high battery level is charged at low temperatures, the SOC may quickly jump to 100%.
- Low-power charging contributes to the service life of high-voltage battery.
- When the vehicle is used for the first time or after a long idle period, the SOC displayed on the instrument cluster may not be correct. It is recommended to fully charge the vehicle first.
- It is recommended to fully charge the vehicle at a regular basis (at least once a week), and fully charge it from low battery (SOC <10%) once every three to six months.
- Under extreme working conditions (such as frequent sudden acceleration/ deceleration) that cause battery overheating, if the temperature of high-voltage battery is excessively high, it is normal for discharging capability to decrease gradually. If the battery temperature keeps rising, the fault warning light lights up on the instrument cluster. In that case, it is recommended to contact a BYD authorised dealer or service provider.

Battery Usage Tips

- It is recommended to use the vehicle at temperatures between 14°F (-10°C) to 104°F (40°C). When SOC is low, timely charge the vehicle to ensure enough driving range and good acceleration performance.
- To ensure long term performance, avoid driving in extreme temperatures for over 24 hours.
- In low ambient temperatures, if the vehicle must be stored for a long time, it can be placed in an underground garage or other warmer area to reduce loss of battery heat, maintaining vehicle performance.
- Frequent and sudden acceleration or deceleration should be avoided. Drive the vehicle on flat and dry roads. When necessary, turn off high-power equipment such as A/C or adjust the A/C temperature to reduce power consumption of such devices and increase the driving range.

WARNING

In the event of an emergency or accident, be aware of the following warnings:

- To avoid personal injury, do not touch the high-voltage battery directly.
- It is recommended to contact a BYD authorised dealer or service provider as soon as possible.
- If the high-voltage battery is damaged and leaking fluid, avoid any contact with the fluid.

WARNING

If it comes into contact with skin or eyes, rinse immediately with plenty of water, and seek immediate medical attention.

- If the vehicle catches fire, use dedicated fire extinguishers instead of water-based fire extinguishers.

CAUTION

- To ensure safety of the high-voltage battery, stop the vehicle away from flammable and explosive materials, ignition sources and various hazardous chemicals.
- The available battery capacity decreases as the vehicle is used over time.
- Prolonged exposure to heat sources and direct sunlight reduce the service life of the high-voltage battery.
- When the vehicle is not to be operated for an extended period (over seven days), it is recommended that the battery SOC should be kept at 40%-60% to prolong its service life. When the vehicle is not to be operated for over three months, the high-voltage battery must be fully charged and then discharged to 40%-60% every three months. Otherwise, over-discharge may lead to battery performance degradation or even damage. Any vehicle fault or damage so caused will not be warranted.
- If there is a collision with the high-voltage battery, contact a BYD authorised dealer or

CAUTION

service provider immediately for maintenance.

Recycling the High-voltage Battery

How to scrap an NEV:

1. Take the vehicle to the BYD recycling service provider that will assess the residual value of the high-voltage battery.
2. Take the assessed vehicle to the recycling organisation to disassemble the high-voltage battery.
3. Take the battery to the recycling service provider which will buy back the battery.

WARNING

- New energy car owners have the responsibility and obligation to hand over waste high-voltage batteries to the recycling service outlet. Anyone who hands over a used high-voltage battery to any other organisation or individual, or removes/disassembles a high-voltage battery without authorisation, shall be liable for any environmental pollution or safety incident so caused.

Low-Voltage Battery

It is positioned under the rear seat, with its access cover near the ankle of the rear middle passenger. With the access cover open, the low-voltage battery's negative terminal and negative GND wiring harness are visible.

- To prevent the SOC of the low-voltage battery becoming too low, the intelligent charging function

is triggered automatically when conditions are met (ignition off, high-voltage battery discharging allowed, and low-voltage battery level below the design value).

- If the battery voltage is too low, it may not be able to power on the vehicle. In that case, contact the BYD authorised dealer or service provider promptly.
- After the vehicle has been in use for 3-5 years, it is recommended that the staff conducting routine maintenance should conduct checks on the low-voltage battery. These include checking the battery terminal for corrosion and whether the battery and terminals are firmly attached.

WARNING

- The low-voltage battery contains a corrosive solution. To prevent damage to the battery or injury, do not disassemble or repair the battery without authorisation.
- Do not disassemble or dismantle the low-voltage battery. Any organisation or individual to do so shall bear the responsibility for environmental pollution or accidents.
- Since the low-voltage battery may produce combustible and explosive hydrogen gas, use tools in such a manner that the battery would not produce sparks. Do not smoke or use open flames near the battery.
- Avoid electrolyte contact with eyes, skin or clothing. In case that happens, use baking soda water to clean the skin, and plenty of water to rinse the eyes, and immediately seek medical attention.

WARNING

- In case of mouth contact with the electrolyte, seek medical attention immediately.
- Keep children away from the low-voltage battery.

CAUTION

- When checking the low-voltage battery, remove the ground cable from the negative terminal (-) first, and reconnect it last.
- When cleaning the low-voltage battery, make sure to avoid any fluid getting inside.

REMINDER

- It is normal that intelligent charging with the ignition off produces a noise similar to when the ignition is switched on.
- Do not carry out maintenance work during intelligent charging.
- When leaving the vehicle, make sure the doors are closed and all electrical equipment is turned off.
- If the vehicle needs to be parked for a long time, please disconnect the negative terminal wire.

Waking up the Vehicle from Low SOC

Wake-up by the driver's door microswitch:

- The low-voltage battery features the dormant/wake-up function. The low-voltage battery may have entered a dormant state after long-term parking. In that case, the vehicle cannot be located or unlocked with the smart key. To wake up the vehicle, hold the

smart key close to the driver's door and press the microswitch on the door for 3 seconds. When unlocked, the vehicle can be used as normal. If these actions cannot wake up the vehicle, the low-voltage battery may have been exhausted.

Wake-up by jump starting*:

If the vehicle cannot be waked up by using the microswitch, use a 12V power supply and two specially designed cables to jump start the vehicle.

- Positive terminal for jump starting: inside the under-bonnet power distribution box (PDB)

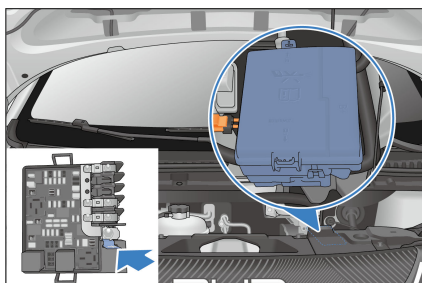

- Negative terminal for jump starting: bonnet latch

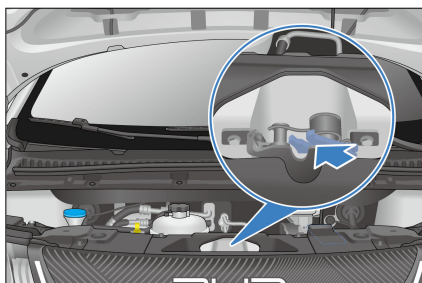

WARNING

- Never jump start another vehicle. This may damage the low-voltage battery.

WARNING

- If the low-voltage battery SOC is too low or the battery fails, jump starting may be required. Please carefully read and strictly follow the jump starting instructions in this manual.
- The low-voltage battery contains an intelligent control module. To prevent battery damage, do not disassemble or damage this battery without permission, except in an emergency.
- Disconnect the negative terminal of the low-voltage battery before performing parts replacement and vehicle repairs.
- Do not clean the low-voltage battery with water, but wipe it with a cloth instead.

CAUTION

- It is recommended that the jump starting be done under the guidance of professionals, as the space for operating the under-bonnet PDB is limited and circuit-based risks are present.

Usage Precautions

Break-in Period

- If the powertrain is hard to start or frequently stops turning, inspect the vehicle immediately.
- If the powertrain makes any abnormal sounds, stop the vehicle for inspection.
- If the powertrain has severe coolant and oil leakage, stop the vehicle for inspection.

- The powertrain needs break-in. This should preferably be done within the first 1,243 miles (2,000 km) in economic mode. Steady driving instead of high-speed driving is recommended. The following practices effectively prolong vehicle service life:
- Avoid flooring the accelerator pedal when starting and driving the vehicle.
 - Avoid speeding.
 - Do not maintain a high or low speed for too long.

Trailer Towing

- This vehicle is designed to carry passengers. Do not overload it or use it to tow other vehicles.
- Towing other vehicles has an adverse impact on the maneuverability, performance, braking, endurance, driving economy, power consumption, and other aspects of performance of the vehicle itself.
- Do not disassemble the rear bumper beam or add any boot-mounted bike rack without authorisation. Issues so caused are not covered by warranty.
- If you want to install a trunk-mount bike rack, go to a BYD authorised dealer or service provider to consult whether this function is supported on your model. Upgrade the hardware there if it is practicable.
- The bike rack can only load no more than three bikes, and only one passenger is allowed in the rear seat when the vehicle is carrying a bike. For the vehicle to carry bike(s), the technically permissible laden mass may be exceeded by not more than 75 kg. For driving safety, avoid speeding and overloading.

- This vehicle is designed to carry bike rack or similar luggage rack. Do not tow a caravan or any other trailers.
- Driving safety and comfort totally depend on equipment usage and good driving habits.
- BYD does not provide free warranty for the damage or faults resulted from the trailer towing.

Driving Safety Precautions

No Drunk Driving

Even a small amount of alcohol can reduce a driver's ability to respond to traffic condition changes. The higher the level of alcohol, the less responsive the driver will be. Therefore, never drive while under the influence.

No Speeding

Speeding is a major cause of fatal accidents. Faster speeds generally entail higher risk. Therefore, maintain a speed safe for the road traffic conditions.

Keeping the Vehicle Safe for Driving

Tyre bursts and mechanical faults are extremely dangerous. To reduce the possibility of such faults, frequently check the vehicle's condition, and regularly complete the specified inspections.



CAUTION

- Any driver must possess a driver's license before driving a vehicle.
- Do not drive when fatigued.
- Always follow the traffic regulations when driving a vehicle.



CAUTION

- When driving, drivers must stay focused and not carry out any unrelated activity, such as answering calls or adjusting buttons.

Vehicle Use Suggestions

Suggestions for prolonging the battery usage:

- When the vehicle is not to be operated for an extended period (over seven days), it is recommended that the battery SOC should be kept at 40%-60%, or it will reduce high-voltage battery service life.
- When the vehicle is not to be operated for over three months, the high-voltage battery must be fully charged and then discharged to 40%-60%. Otherwise, over-discharge may lead to battery performance degradation or even damage. Any vehicle fault or damage so caused will not be warranted.
- During operation of the vehicle, if the instrument cluster displays the pure electric driving mileage as 0, it indicates the battery SOC is low. In this case, charge the high-voltage battery in time and avoid operating the vehicle with low SOC for a long time.
- For optimal battery performance, use a charging connector to fully charge the battery regularly, and the recommended frequency is once a week at least.
- To maintain long-term performance, avoid continuously exposing the vehicle to an environment with a temperature above 140°F (60°C) or below -22°F (-30°C) for over 24 hours.
- If the tray dented inward or there is scarification under the battery package

tray, it is suggested to check at a BYD authorised dealer or service provider.

- During operation of the vehicle, avoid repeated rapid acceleration or deceleration whenever possible.
- During operation of the vehicle, avoid operating the vehicle continuously for a long time whenever possible; otherwise, the excessively high battery temperature will affect vehicle performance.
- If the instrument cluster malfunctions when driving, it is recommended to contact a BYD authorised dealer or service provider for inspection as soon as possible.
- When the high-voltage battery temperature is high, the vehicle performance will be limited to some extent. In this case, stop the vehicle and wait until the temperature drops before operating.



REMINDER

- If the meter drops to 0, the battery must be recharged. If it is not recharged within seven days, the battery may suffer permanent damage. Such damage is not covered by BYD warranty terms.
- Driving range depends on many factors, such as the vehicle's available power, vehicle age (current battery life), weather, temperature, road conditions and driving habits. Compared with under normal temperatures, the pure-electric driving range is somewhat reduced and power performance will also be affected in low or high temperature environments.

Carrying Luggage

- This vehicle has multiple storage spaces. Overloading or improper accommodation may affect maneuverability, stability and normal operation of the vehicle, and reduce its safety.
- Make sure the vehicle's total load (vehicle + passengers + luggage) remains within the specified maximum weight.

WARNING

- Overloading and improper accommodation may affect vehicle maneuverability and stability, which may lead to collisions.
- Observe the maximum weight limit and other loading guidelines in this manual.
- Do not carry highly magnetic items, as they might interfere in the vehicle's normal operations.

Carrying Items in the Passenger Area

- All items that could be thrown inwards and thus injure occupants in case of a collision must be properly placed and secured.
- Ensure that items placed on the floor behind the front seat do not roll under the seat, so as to avoid affecting the driver's ability to control the pedals or normal seat adjustment. Do not stack items to a height taller than the front seats' seatbacks.
- Make sure the glove box is always closed while driving. If the glove box is open, the occupant's knees may be injured in case of a collision or an emergency stop.

REMINDER

- Do not pile up toys in the vehicle, as this may affect driving safety and present a hazard to the children, especially in case of emergency braking or collision.

Loading the Boot

- Place luggage evenly in the boot. Put heavier items at the bottom and as far in as possible.
- Secure items with ropes or straps so that they will not move while driving. Do not stack items to a height taller than seatbacks.
- For boot strapping or fastening supplies, contact a BYD authorised dealer or service provider.

Wading into Water

- Check water depth before driving into flooded areas, it must not exceed the vehicle's lower edge.
- If crossing a flooded area is necessary, turn off the air conditioner and keep acceleration steady to slowly cross over.



- Never stop, back up, or turn off the vehicle in flooded areas.

- After crossing over, press the brake pedal several times to dry out the disks and recover brake performance.
- Be careful when driving through deep water, as brakes may get wet.

WARNING

- The presence of water, mud, or silt in the braking system may delay brake response and extend braking distance.
- Drive carefully and avoid emergency braking after crossing flooded areas.
- The motor will be seriously damaged if it is submerged when crossing a flooded area. Such damaged is not covered by the vehicle's warranty
- Other systems like transmission, driving and electrical systems may also be seriously damaged upon submersion. Such damage is not covered by the vehicle's warranty either.

Influence of water ingress in high-voltage components:

- Water getting into high-voltage components, which are electronic devices, may not be fully dried out by any means.
- Water ingress seriously compromises insulation of high-voltage components, and conductive substances in water may lead to short circuit of high-voltage components or such risk in the entire high-voltage system. This significantly affects the safety and service performance of the vehicle.
- The reduced ingress protection rating and voltage withstanding performance due to water in high-

voltage components pose a high safety risk.

- Be sure to find a sheltered place when charging the vehicle on rainy days. If the vehicle is immersed in water or wades through water over the doorsill, which may cause water ingress in high-voltage components, promptly contact a BYD authorised dealer or service provider for testing and troubleshooting. Do not drive on roads where the depth of accumulated water exceeds half of the tyres.

Fire Prevention

To prevent vehicle fires in a timely and effective manner, pay attention to the following during use of the vehicle:

- No flammable or explosive items are allowed in the vehicle.
 - Temperatures may reach 140°F - 158°F (60°C - 70°C) in a vehicle exposed to direct sunlight in summer. Therefore, flammable and explosive items, such as lighters, cleaning agents and perfumes, stored in the vehicle can cause a fire or even explosion easily.
- Make sure cigarettes are thoroughly put out.
 - Smoking is harmful to your health and may cause a fire. Cigarettes that not thoroughly put out may cause a fire.
- It is recommended to go to a BYD authorised dealer or service provider for regular vehicle checks.
 - Check vehicle wiring, connections, wiring harnesses, insulation, and fixed position regularly. Deal with identified problems promptly.
- Do not refit vehicle wiring or add any unauthorised electrical appliance.

- The addition of extra electrical appliances, such as high-power audio systems, and light fixtures, may overload and overheat the wiring harness and increase the risk of fire.
- Improper refitting of electrical appliances or wiring may cause a fire due to contact resistance and abnormal heating. Fuses or other replacement wires in excess of relevant electrical rating are strictly prohibited.
- Select a proper parking location.
 - When parking the vehicle, try to avoid sun exposure.
- Keep a lightweight fire extinguisher in the vehicle and know how to use it.
 - In order to ensure vehicle safety, a fire extinguisher should be equipped in the vehicle, and be checked and replaced regularly. Also, you should familiarise yourself with use of the fire extinguisher and be prepared for any accidents.
- Disconnect the negative cable of the low-voltage battery when the vehicle is being serviced or repaired.
- In the event of a fire in the vehicle, take effective measures in a timely and calm manner to minimise any losses:
 - Fires typically show initial warning signs, such as abnormal noises and odours in the vehicle body. When abnormal conditions are found, turn off and stop the vehicle immediately. It is best to park the vehicle in a windproof place, and then put out the fire using the fire extinguisher in the vehicle.
 - Call the fire alarm in time, and also dial the insurance company's reporting number and ask the company to come to the fire site for handling.
- Look for the ignition point. If the engine compartment smokes, do not open the bonnet immediately. (This will let a large amount of air in and cause fire spreading. There is limited comburent in the cabin. Keeping the bonnet closed can control the fire so that the fire can be easily put out). Point the on-board fire extinguisher at the ignition point from the bonnet gap to put the fire out, or seek help from the passing cars. If you can borrow more fire extinguishers, open the bonnet to put it out when you cannot see any flame from outside.
- If the fire brigade is involved, ask for a duty performance certificate and a description of fire cause.
- After occurrence of the accident, contact the insurance company for post-event handling in a timely manner.

**REMINDER**

- In order to mitigate losses in the event of an accident, the purchase of commercial insurance (fire loss, theft, etc.) is recommended.

Saving Energy and Extending Vehicle Service Life

Saving Energy and Extending Vehicle Service Life

Starting and Driving

Starting the Vehicle

In normal cases, start the vehicle as below:

- Turn off all the unnecessary lights and accessories.
- Carry the correct smart key with you.



- Press the START/STOP button while pressing the brake pedal.
- The vehicle is ready to drive when the OK indicator lights up on the instrument cluster.

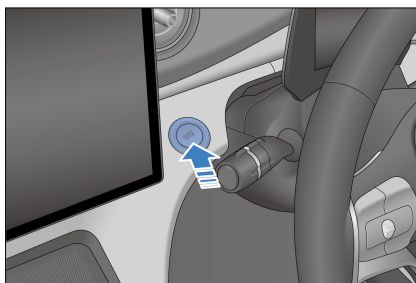

- The vehicle cannot power on when:
 - After you press the START/STOP button, the smart key warning light turns on, a beep sounds, and the message "No key detected" is displayed on the instrument cluster. This means that the key is not in the vehicle or cannot be detected due to interference.
 - The electronic smart key is on the floor, or in the boot or glove box.



CAUTION

- When the vehicle is not started, if the driver is unable to start the vehicle after entering the vehicle for one minute, it is recommended to move the electronic smart key and try again.

To start the vehicle in emergency if the braking signal cannot be detected or is erroneous:

- Engage the parking brake firmly.
- Turn off all the unnecessary lights and accessories.
- Shift to "P" or "N" .
- The power mode is "OFF".
- The electronic smart key is in the vehicle.
- Press and hold the START/STOP button for more than 15 seconds to start the vehicle.



REMINDER

- Do not touch the power button while driving.

Remote Start*

Before starting

1. The power mode is "OFF".
2. The gearshift lever is on "P".
3. The vehicle speed is below 3 mph (5 km/h).

Remote Start with the Electronic Smart Key

1. Press and hold the remote start/stop button on the electronic smart key for two seconds to start the vehicle. After it is started, turn signals will flash three times.
2. If there is no valid operation within 10 minutes after remote start, the vehicle stops and powers off, and turn signals flash twice.

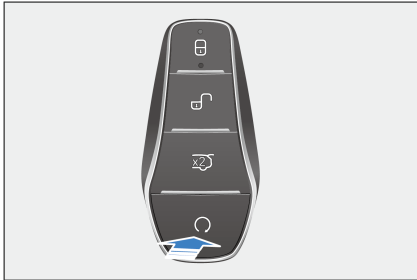

3. After the vehicle is started, pressing and holding the remote start/stop button on the smart key for two seconds switches the ignition off. The turn signals then flash twice.

Driving

Safety Check Before Driving

Exterior

- Tires: Check tyre pressure and carefully inspect tyres for any cut, damage, foreign material, anomaly, and excessive wear. In case of excessive or uneven tyre wear, take the vehicle to a BYD authorised dealer or service provider for four-wheel alignment and relevant inspections as soon as possible.
- Lug nuts: Ensure all nuts are fitted and tightened.
- Leaks: After the vehicle has been stationary for some time, check for fluid deposits beneath it. These may indicate a leak of coolant or other liquids. (It is, however, normal for a small pool of water to form, caused by the air conditioning system.)
- Lighting: Make sure headlights, position lights, turn signals and all other lights are working normally. Check headlight intensity.

Interior

- Seat belts: Check whether seat belts can be properly fastened. Verify that seat belts are not worn or scratched.
- Instrument cluster: Particularly, verify that maintenance indicator, instrument cluster lighting, and defroster work properly.
- Braking: Verify that there is enough space for the brake pedal to work.
- Low-voltage battery and cables: Check connectors for any corrosion or looseness and any cracks in the battery housing.

In the engine compartment

- Spare fuses: Verify that spare fuses of all rated charges in the fuse box are available.
- Coolant level: Verify that coolant level is correct.
- Brake fluid level: Verify that the brake fluid level is correct.

Check after starting

- Instrument cluster: Confirm that the maintenance indicator and the speedometer work normally.
- Brakes: In a safe area, drive the vehicle straight, hold the steering wheel tightly, decelerate and apply the brake. Verify that the vehicle maintains a straight direction.
- Other abnormalities: Check for loose parts, leaks, and unusual noises.

Preparations Before Driving

- Check your surroundings before getting into vehicle.
- Adjust seat position, seatback angle, cushion height*, head support height, and the steering wheel angle.
- Adjust interior rearview mirror and side mirrors.
- Make sure all doors are closed.
- Fasten the seat belts.

Gear Shift Controls

The gear options are marked on the instrument cluster switches as shown.

- "R": Reverse, used only when the vehicle has come to a complete stop.
- "N": Neutral, used for temporary stop. Under all circumstances, always shift to "P" before getting out.

- "D": Drive. Shift to "D" to drive the vehicle normally.

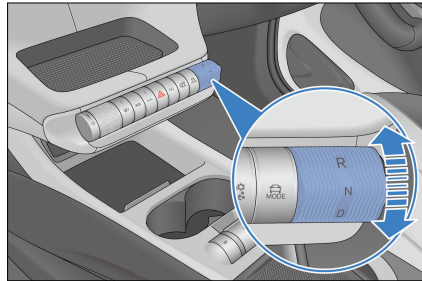

- "P": Parking. Press this button to park the vehicle. The transmission should be set to this position when the vehicle is being shut down or started up. By pressing the brake pedal to start the vehicle, you can shift from Park to another position.

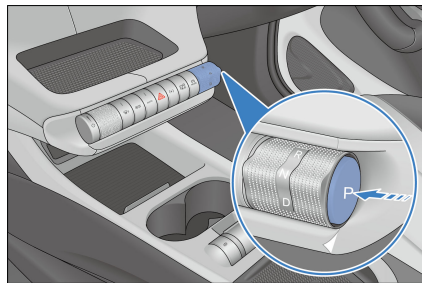

WARNING

- It is not recommended to allow the vehicle to go down a ramp when it is in the "N" or "P" gear, even if the vehicle is not started.

CAUTION

- To prevent inadvertent vehicle movement, apply the parking brake when the vehicle comes to a full stop and press the "P" button.
- To prevent damaging the transmission, press the "P"



CAUTION

button only after the vehicle has completely stopped.

Electronic Parking Brake (EPB)

EPB Switch

- Be sure to engage the Electronic Parking Brake (EPB) every time before parking and leaving the vehicle.

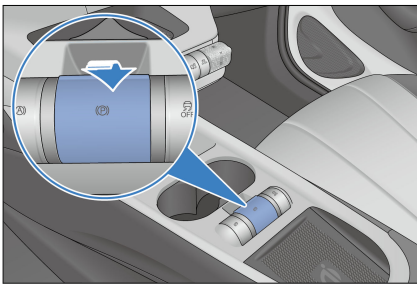

Engaging EPB Manually

Engage the EPB switch manually. EPB applies an appropriate parking force, and (P) flashes on the instrument cluster and then becomes solid on, indicating that EPB has been applied. The "EPB activated" message is also displayed.



CAUTION

- When (P) flashes, EPB is working. If the vehicle is on a slope, do not release the brake pedal until (P) is steady on. Otherwise the vehicle may move down.

Engaging EPB Automatically

This function is designed to improve vehicle safety. Excessive reliance on or frequent use of the function is not

recommended. For safety reasons, make sure that the vehicle is shifted into Park or the EPB is engaged before getting off.

- When the ignition is switched off, EPB is engaged automatically and (P) lights up on the instrument cluster.
- Press the brake pedal to stop the vehicle and shift into Park. EPB is engaged automatically. Do not release the brake pedal until the indicator (P) on the instrument cluster stops flashing and becomes steady on and the "EPB ON" message is displayed.
- Press the brake pedal to stop the vehicle and engage the EPB continuously, and open the driver's door after shifting into Park or Drive. Do not release the brake pedal until the indicator (P) on the instrument cluster stops flashing and becomes steady on and the "EPB ON" message is displayed.



CAUTION

- The EPB is not automatically engaged if you switch off the ignition immediately after pressing the EPB switch.
- To activate electronic parking brake trailer mode for vehicle towing when the vehicle breaks down or for brake pad replacement, go to infotainment touchscreen → Settings → DiLink → Overhaul.

Releasing EPB Manually

- When vehicle has been powered on and is not shifted into P (Park), press and hold the brake pedal and the EPB switch until the indicator on the instrument cluster goes out, indicating EPB has been released, and an "EPB released" message is displayed.

CAUTION

- The P gear is the vehicle's parking gear, meaning that the vehicle is in a stable parking status, while EPB is the vehicle's main parking device. To ensure parking safety, release EPB with the EPB switch only when the vehicle is not in P gear (parking gear).

Automatic EPB Release upon Vehicle Start

Releasing by shifting gear:

- With the vehicle parked, start the vehicle, press and hold the brake pedal, and shift from "P" or "N" into a driving gear such as "D" or "R". EPB is released automatically, the indicator goes off, and the "EPB released" message is displayed.

CAUTION

- Be sure to always press and hold the brake pedal when shifting gears. Release the pedal only after the intended gear is displayed on the instrument cluster.
- Within several seconds after the vehicle is started, the EPB system performs a power-on self-test (POST). In this process, the EPB system does not respond to any operations.

Releasing by pressing the accelerator pedal:

- When the vehicle has been started and in Drive or Reverse, engage EPB by enabling EPB on the infotainment system, then press the accelerator pedal slowly to a certain degree. EPB is released automatically and  turns off with the message "EPB released" displayed.

WARNING

- For safety considerations, refrain from using EPB for braking in normal driving. It is preferred to be used when the brake pedal fails or is blocked.
- As the EPB cannot go beyond the physical limit of road adhesion, activating the emergency brake function may result in vehicle drift, sideslip, or deflection when the vehicle passes through bends or dangerous/heavy-traffic road sections, or when the vehicle is driven under severe weather conditions. Be careful to avoid any possible accident.

If EPB Release Fails

If manual EPB release fails, press and hold the EPB switch for over two seconds. If EPB can be released, drive the vehicle to the nearest repair shop to check the brake pedal switching signal and relevant parts and lines. If it cannot be released, contact a BYD authorised dealer or service provider immediately.

Emergency Braking When Brake Pedal Fails

When the vehicle is in motion and ESC system is functional, controlled deceleration for parking brake (CDP) can be used if the brake is stuck or fails. If only EPB is engaged, the braking deceleration is 0.4 g; if EPB is engaged and the brake pedal is pressed, the braking deceleration is 0.8 g. Avoid using EPB for forced braking, but only activate emergency braking in case of emergencies such as brake pedal failure or sticking.

EPB System Indicator

- When the vehicle is powered on, if the EPB is engaged, (P) is solid on on the instrument cluster.
- When the vehicle is powered off, if the EPB is engaged, (P) on the instrument cluster turns on and then turns off in three seconds.
- When the vehicle is powered on, the EPB system starts self-check. (P) turns on and then turns off in about three seconds on the instrument cluster. If it does not, the EPB or braking system may be faulty. In this case, contact a BYD authorised dealer or service provider immediately.

EPB Operating Sound

- EPB motor noises can be heard while the EPB is being engaged or released.
- If there is a burning smell or unusual noises after emergency braking is activated, contact a BYD authorised dealer or service provider immediately.

WARNING

- To prevent the vehicle from moving, the gearshift is not to be used to replace EPB when parking. EPB must be used instead, and the vehicle must be in "P" gear.
- The EPB switch must not be operated when the vehicle is moving.
- When the EPB is being engaged or released, the brake pedal must be pressed to prevent the vehicle from moving, and the subsequent locking of the gearshift that occurs because the EPB cannot provide a sufficient parking force.

Automatic Vehicle Hold (AVH)

Auto Vehicle Hold (AVH): The automatic vehicle hold (AVH) is activated automatically when the moving vehicle needs to be stationary for longer periods of time, such as in traffic jams on a slope or waiting at traffic lights.

AVH standby

- When the ignition is on, press the AVH switch to enable AVH. (A) is displayed on the instrument cluster.
- Press the AVH switch again to disable AVH.

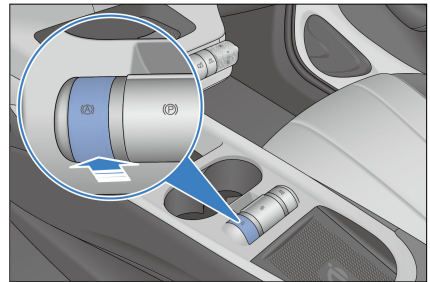

AVH activated

- When the AVH standby indicator (A) is solid on, press the brake pedal until the vehicle stops (vehicle speed goes to zero) to activate AVH function. At this time, the vehicle is in AVH state with (A) displayed on the instrument cluster.

CAUTION

- For AVH to be activated, all of the follow conditions must be met:
 - The driver's seat belt is fastened and the doors are closed.
 - Intelligent power braking system and electronic park brake (EPB) systems are normal.



CAUTION

- Pressing the accelerator pedal, shifting into Park, or activating the EPB cause AVH to exit to the standby status.
- The AVH defaults to off once the vehicle is powered up.
- The next time the ignition is switched on, AVH restores to the on/off status the last time the ignition was switched on.

AVH running

- The AVH function runs normally when the AVH function is activated, brake lights and the high mount brake light are on, and the AVH indicator (A) is solid on on the instrument cluster.
- The AVH function exits to the standby mode after the vehicle stops for 10 minutes, with the AVH standby indicator (A) lighting up and gear shifted into Park
 - To activate AVH function, shifting into Drive to enable the vehicle to move, and then press the brake pedal until the vehicle stops (vehicle speed goes to zero).

AVH exits

- When the AVH function runs normally, AVH exits and the gear is shifted into Park from Drive automatically when the driver performs the followings:
 - Open the driver's door.
 - Unlock the driver's seat belt.
 - The gear status is in Drive when the vehicle stops, and EPB is enabled.
 - Press the AVH switch again to disable AVH when releasing the brake pedal.

AVH suppressed

- Shifting into Reverse, AVH goes into slow-moving condition. When the vehicle is reversing (R gear) or travelling (shift into D gear from R gear) at a low speed, AVH cannot be activated and stays in standby status to improve vehicle motion.
- To exit slow-moving mode, drive at a speed above 10 km/h or restart AVH after exiting.

Driving Precautions

- Drive slowly and carefully along gravel roads. To prevent tyre damage, do not drive over sharp-edged obstacles.
- Slow down on bumpy or uneven roads. Otherwise, the impact may seriously damage wheels.
- Avoid driving through flooded areas as much as possible.
- Slow down when driving against strong winds.
- Cleaning the vehicle or driving through deep water may wet brakes. To keep brakes dry, drive carefully and press the brake pedal gently.
- Drive carefully on slippery roads, such as roads covered in ice, snow or sand, or surfaces such as wet ceramic tiles or epoxy resin. Avoid parking on slopes to prevent vehicle sliding.



WARNING

- Drivers must ensure the safety of all vehicle occupants, and show them how to handle the vehicle's functions properly.

REMINDER

- The battery is located in the vehicle's chassis. Make sure to avoid bumping when driving.
- Before driving, make sure that EPB is fully released and that the EPB indicator light is off.
- Do not leave the vehicle with ignition on.
- Do not rest your feet on the brake pedal and accelerator pedal for a long time during driving. Otherwise, this will cause overheating, wear and waste of electric energy.
- Remember to carry the smart key when leaving the vehicle.
- Slow down when driving down steep slopes, and avoid braking too frequently to prevent disc overheating, which affects brake performance.
- Be careful when accelerating or braking on slippery roads. Quick acceleration or sudden braking will cause the vehicle to skid or deviate.
- Make sure no occupant sticks their head or hands outside the vehicle, specially when it comes to children.
- Large amounts of water entering the engine compartment can cause damage to the power system and electrical components.

Winter Driving Precautions

- Make sure the coolant is freeze-proof.
- Use coolant of the same type as the one used originally. Fill up coolant

into the cooling system based on ambient temperature.

- Improper coolant damages the cooling system.
- Check batteries and cables conditions.
 - The low-voltage battery's capacity is lower in cold weather, so they must be fully charged when winter comes.
- Avoid door frost.
 - Spray some deicing agent or glycerin in the lock hole to prevent freezing.
- Use anti-freeze washer fluid.
 - These can be found in the BYD authorised dealer or service provider and the auto parts stores.
 - The water and anti-freeze ratio must conform to manufacturer instructions.



CAUTION



- Use special washer fluid to prevent paint damage.
- Prevent ice and snow from going under the fender.
 - Steering is difficult with ice or snow accumulating under the fenders. When driving in cold weather, stop from time to time and check for snow and ice under the fenders.
- Have emergency tools or items available as prevention for difficult road conditions.
 - It is advisable to have snow chains, window scraper, bags of sand and salt, flashing signal, a shovel and connecting cables in the vehicle.

Driver Assistance

Adaptive Cruise Control (ACC)

- The adaptive cruise control (ACC) system, an extension of the traditional cruise control, uses a radar and a multi-purpose camera to detect the relative distance and speed of the vehicle ahead, so as to control vehicle speed accordingly. The system switches between regular cruise control and ACC according to whether there is a vehicle ahead.
- Cruise speed and time interval from the vehicle ahead can be set by using the cruise buttons. You can set the cruise control speed within the 20-95 mph (30-150 km/h) range, or set a fixed distance from the vehicle ahead to cruise at speeds between 0 mph and 95 mph (150 km/h).

Status Description

- ACC standby:
 - Once enabled, the system is on standby by default and can be manually activated. If the vehicle does not meet activation conditions, it must be checked until such conditions are met. At this time,  (with a variable cruise speed value) is displayed on the instrument cluster.
- ACC activated:
 - The system is operational. It maintains the set speed or automatically adjusts the distance from the vehicle ahead. At this time,  (with a variable cruise speed

value) is displayed on the instrument cluster.

- Over speed:
 - When you step the accelerator pedal while ACC is active, the vehicle responds to your acceleration action so that the ACC is temporarily deactivated until you release the pedal.
- ACC failure:
 - There has been a failure in the system. No operation can be performed, and the ACC failure indicator  is displayed on the instrument cluster.

ACC Activation Conditions

- The EPB has been released.
- The vehicle is in Drive.
- The vehicle does not slide backwards.
- The boot, bonnet and all doors are closed.
- Driver seat belt is fastened.
- The ESC system is on, but not activated yet.
- Vehicle speed is equal to or less than 95 mph (150 km/h).
- Brake pedal is pressed at speed 0; or brake pedal is not pressed at speeds above 0.
- There is no vehicle network communication failure prompt on the instrument cluster.
- The AEB function is not activated.

How to Use

ACC on/off button

- Press button ② to activate or exit ACC. (The system is in standby when

activation conditions are met). (By default, ACC activation by pressing button ② sets the current speed as the cruise speed. If the current speed is less than 18 mph (30 km/h), the cruise speed is set to 18 mph (30 km/h).)

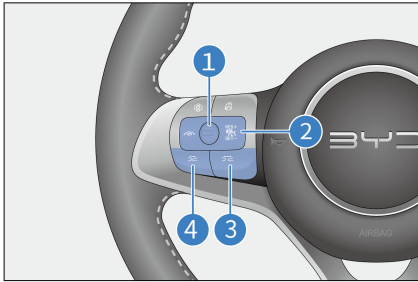

Resetting ACC

- When the ACC system is on standby within the same ignition cycle, the system memorises the last speed setting. Push up the lever ① to revert to the stored speed prior to exiting the cruise system.

Increasing/Decreasing target speed

- When ACC is active, set the vehicle to a speed within the 19-93 mph (30-150 km/h) range by moving the lever ①. You can increase or decrease target speed by 5 km/h with a short toggle of the lever ①, and 1 km/h with a long toggle of the lever ①.

WARNING

- Please strictly abide by the local speed limit regulations, drive safely, and do not speed.

Exiting ACC

- While ACC is active, pressing button ② for a second time or pressing the brake pedal makes the ACC system go on standby.

Setting vehicle distance

- The driver must select a safe vehicle distance.
- The system adjusts vehicle speed to keep a suitable distance from the vehicle ahead on the same lane. Pressing buttons ③ and ④ on the steering wheel adjusts vehicle distance to any of the four available levels. At each level, vehicle distance is in direct proportion to vehicle speed. The faster the speed, the longer the distance.

Increasing/Decreasing speed with ACC active

- When ACC is activated, you can accelerate by actively pressing the accelerator pedal; the assisted driving cannot brake while the accelerator pedal is pressed
- When the target cruise speed setting is less than 80km/h, the driver can press the driver's pedal to increase the target cruise speed setting.
 - If the accelerator pedal is pressed until the real-time speed is greater than the target cruise speed setting and the real-time speed is less than 80km/h, the target cruise speed setting is equal to the real-time speed when the accelerator pedal is released.
 - If the accelerator pedal is pressed until the real-time vehicle speed is greater than the target cruise speed setting and the real-time vehicle speed is equal to or greater than 80km/h, the cruise speed setting is equal to 80km/h when the accelerator pedal is released.
- When the cruise speed setting is equal to or greater than 80km/h, the driver can temporarily increase the real-time speed by pressing the accelerator pedal, and when the accelerator pedal is released, the target cruise speed setting remains unchanged.

- If you press the accelerator pedal at the same time, you can accelerate up to 5km/h with a short press of the button, and 1km/h continuously with a long press of the button. If the vehicle speed is greater than 135km/h or the accelerator pedal is pressed continuously for more than 5min, the ACC function exits.

Follow-to-stop/start

- Controlled by ACC, the vehicle can stop when the vehicle ahead stops in normal driving conditions and resume driving automatically following the vehicle ahead if the stop is less than 30 seconds.
- If the vehicle stops for a time period between 30 seconds and three minutes, press the accelerator pedal or push up lever ① to reactivate ACC.

System Limitations

- The front mmWave radars are installed in the front of the vehicle. Blockage of its detection area by contaminants can disturb the intended function. In particular, if the sensor is covered by snow completely, the ACC system exits and informs of this on the instrument cluster. System function will recover after blockage is removed and the vehicle is restarted or runs on normal roads for a while.
- Front mmWave radars may have a transient function failure from limited detection if the vehicle runs under special conditions, such as circular ramps or tunnels, for an extended period. The function can be recovered by restarting the vehicle or driving on normal roads for a while.
- Reaching or leaving a curve may delay or disturb target selection. In such cases, the ACC vehicle may not brake as expected or may brake late.

- On roads with sharp curves, such as winding roads, the vehicle ahead may be out of ACC sensor detection for several seconds due to sensor vision limitations, possibly causing the ACC vehicle to accelerate automatically.
- Traffic flow and weather conditions - such as rain and fog - must be heeded for setting vehicle distance on the ACC system. After the ACC system is properly set, the driver must be able to decelerate until the vehicle stops at any time.
- The ACC system may not be able to identify stationary or slow-moving objects, such as vehicles, the end of traffic, toll booths, bicycles, motorcycles or pedestrians. This means a risk of collision and requires the driver to beware of the surroundings.
- The ACC system cannot identify pedestrians or oncoming vehicles.
- The ACC system can only achieve limited braking instead of emergency braking.
- Metal objects, such as rail or metal plates used in road construction, may interfere with front mmWave radars, making it malfunction.
- Performance of front mmWave radar sensors may be affected by vibration or collision. In this case, it is recommended to contact a BYD authorised dealer or service provider.

Precautions

- ACC is a comfort system rather than a safety system, obstacle detector or collision warning system. The driver must keep control of vehicle at all times and be fully responsible for the vehicle.

- ACC assists instead of replacing the role of the driver. The driver is responsible for abiding by traffic rules and keeping vehicle control.
- For safety reasons, ACC cannot be activated with ESC disabled.
- The ACC is suitable for motorways and roads in good conditions, rather than complex urban or meandering roads.
- It is the driver's responsibility to keep distance from the vehicle ahead. The ACC system's vehicle distance meets the minimum distance required in driving environments in the country.
- Vehicle control is transferred to the driver if the accelerator or brake pedal is pressed with ACC active. As a result, the ACC system cannot keep a safe distance from the vehicle ahead.
- ACC may have no or slow responses to a vehicle ahead that brakes or stops suddenly, resulting in a risk of late braking. In such cases, there will be no take-over request.
- In some cases, such as when the vehicle ahead is going too slow, when lane change is too fast, or when the safe distance from the vehicle ahead is too short, there is no adequate time for the system to decrease the relative speed, so response has to come from the driver. The system cannot give audible or visual warnings in every case.
- If ACC is activated with the vehicle stationary, the system identifies any stationary obstacle ahead and keeps the vehicle still to ensure a safe startup and prevent collision. However, this function cannot identify all the obstacles, so the driver must be alert to the front obstacles or other traffic participants.
- A short distance from an adjacent lane (or a vehicle on an adjacent lane that is too close to the ACC vehicle's lane) may trigger ACC to brake.
- Vehicles coming into the ACC vehicle's lane and within the detection range of its front mmWave radars are identified as target vehicles and prompt a response accordingly, which may lead to hard or late braking.
- Detection may be affected or delayed in some environments. If the radar cross section of the target (a bicycle, motorcycles, four-wheeler, or pedestrian, for example) is too small, the system may not be able to establish its distance, resulting in either late or no response to those vehicles. In such cases, vehicle speed must be controlled by the driver. In addition, detection may also be affected or delayed by noise or electromagnetic interference.
- ACC cannot target vehicles with too small contact ratio, so the driver must keep control of the vehicle.
- When the vehicle stops as it follows a vehicle ahead, in rare cases, the system does not recognise the end of the vehicle ahead but the lower end of the target (for example, the rear axle of a truck with a high chassis or a vehicle bumper). In such cases, the system cannot ensure proper stop distance, so the driver must stay alert and be ready to brake.
- Modifying the vehicle structure, such as lowering the chassis or changing the front license mounting plate, may affect the ACC system.
- Do not use the ACC system when visibility is poor, or when driving on slopes, winding roads, or wet roads (covered in ice/snow or flooded).
- ACC cannot be activated if special driving modes* such as tow/snow/mud/sand/terrain are enabled.

- Make sure to go to a BYD authorised dealer or service provider for professional calibration and checking of front mmWave radars or the multi-purpose camera in any of the following situations:
 - The front mmWave radar, front bumper, or front windscreen has been removed.
 - Wheel alignment has been carried out.
 - The vehicle has experienced a collision.
 - ACC system performance has degraded or the instrument cluster has prompted a system error.

WARNING



- ACC serves as a driver assistance function only, so the driver is fully responsible for driving safety.
- Influence of weather, road conditions, and other factors may cause ACC to fail.
- Use ACC based on your needs, traffic, and road conditions.

Intelligent Cruise Control (ICC)

- The Intelligent Cruise Control (ICC) system integrates ACC and lane centring control (LCC). It helps control the vehicle both longitudinally and transversely at speeds between 0 mph (0 km/h) and 74 mph (120 km/h) to reduce the driving burden and provide a safe and comfortable driving environment.
- When the function is enabled, the driver must always hold the steering wheel and control the vehicle when necessary.

- Longitudinal assistance, driven by the ACC system, keeps the vehicle at a fixed speed or a fixed distance from the road user ahead.

Status Description



- ICC standby:
 - The ICC system is on standby by default and can be manually activated. If the vehicle does not meet activation conditions, the vehicle must be checked until such conditions are met. At this time,  is displayed on the instrument cluster.
- ICC activated:
 - The ICC system is operational. It maintains the set speed or automatically adjusts the distance from the vehicle ahead. At this time,  is displayed on the instrument cluster.
- ICC failure:
 - There has been a failure in the system. No operation can be performed, and the ICC fault indicator  lights up on the instrument cluster.

ICC Activation Conditions

- The EPB has been released.
- The vehicle is in Drive.
- The vehicle does not slide backwards.
- The boot, bonnet and all doors are closed.
- Driver seat belt is fastened.
- The ESC system is on, but not activated yet.

- Vehicle speed is not greater than 75 mph (120 km/h).
- Brake pedal is pressed at speed 0; or brake pedal is not pressed at speeds above 0.
- There is no vehicle network communication failure prompt on the instrument cluster.
- The AEB function is not activated.
- Two-way lane lines are clear and the vehicle is at the centre of the lane.

How to Use

- Press the  button on the steering wheel to activate or exit ICC. (By default, when the function is activated, the current speed is set as the cruise speed. If the current speed is less than 18 mph (30 km/h), the cruise speed is set to 18 mph (30 km/h)).
- For how to set the cruise speed and vehicle distance, see ACC function descriptions (in the previous chapter).
- You can also turn ICC on or off in  → ADAS → Intelligent Driving. (If already toggled on on the infotainment touchscreen, ICC can be toggled off only when the vehicle is in Park.) When the vehicle is just started up, ICC status before the last power-off is maintained.

Precautions

- ICC integrates ACC and LCC. Therefore, ACC function precautions must be followed during use (see the previous chapters for details).
- When ICC is turned on and activated at vehicle speeds between 0 mph (0 km/h) and 74 mph (120 km/h):
 - If there is no lane lines ahead, transverse ICC control is suppressed and only ACC works. In that case, ICC working status indicator turns grey on the instrument cluster.
- If lane lines ahead are clear and recognisable, transverse ICC control is activated automatically. In that case, ICC working status indicator shows activated status on the instrument cluster.
- ICC serves as a driver assistance system rather than an autonomous driving system. The driver should always maintain control of the vehicle, and their hands should not leave the steering wheel for too long. Otherwise, the system will exit after prompting the driver to take control.
- The ICC system can be affected by weather conditions, lighting and clarity of lane lines. Performance degrades significantly in situations such as backlighting, sunset, snow covered roads, and severely damaged roads.
- Do not use the ICC system on winding roads with sharp turns, icy and slippery bends, or under weather conditions, such as dense fog, heavy rain and heavy snow, liable to hinder the sensing operation of front mmWave radars or the multi-purpose camera.
- Situations where ICC cannot be used include:
 - The sensor is blocked.
 - The vehicle is running under severe weather conditions.
 - Active safety function has been triggered.
 - Vehicle speed exceeds the specified range.
 - ICC cannot be activated if special driving modes* such as tow/snow/mud/sand/terrain are enabled.



WARNING



- ICC serves as a driver assistance function only, so the driver must be fully responsible for driving safety.
- Influence of weather, road conditions, and other factors may cause ICC to fail.
- Use ICC based on your needs, traffic, and road conditions.

Predictive Collision Warning (PCW) & Automatic Emergency Braking (AEB)

Predictive Collision Warning (PCW) system and Automatic Emergency Braking (AEB) system detect vehicles and pedestrians ahead by using a radar and a multi-purpose camera. When detecting a risk of collision, the system gives audible and visual alarms to alert the driver and improves the potential braking pressure for better response timing. If detecting increased risk of collision, the system automatically applies braking pressure to assist in collision avoidance or impact reduction.

How to Use

- Enable or disable the PCW and AEB in  → **ADAS** → **Active Safety**.
- PCW gives alarms in forms of audio, messages, and intermittent braking.
- When PCW is activated,  or  flashes, depending on the level of emergency, and a prompt message is displayed on the instrument cluster.

- When AEB is triggered,  and a prompt message are displayed on the instrument cluster.
- In the event of malfunction,  is displayed.
- If you disable AEB manually by pressing buttons,  is displayed.

PCW Activation Conditions

- This function has been turned on in **Vehicle Settings**.
- Vehicle speed is within the 8km/h-150km/h.
- The vehicle is in Drive.
- The vehicle does not slide backwards.

AEB Activation Conditions

- This function has been turned on in **Vehicle Settings**.
- Vehicle speed is within the 3-93 mph (4-150 km/h) range.
- The Electronic Parking Brake (EPB) has been released.
- The vehicle is in Drive.
- The vehicle does not slide backwards.
- The boot, bonnet and all doors are closed.
- Driver seat belt is fastened.
- The ESC system is on, but not activated yet.

System Limitations

- Detection may be affected or delayed in some environments. If the radar cross section of the target (a bicycle, three-wheelers, four-wheeler, or motorised bicycle, or motorcycle, for example) is too small, the system may not be able to establish its

distance, resulting in either late or no response to those vehicles.

- The system may be affected or give no response in the following cases:
 - On rainy, snowy or foggy days, large water splashes, or exposure to direct sunlight or glaring lights, or significantly varying lighting conditions.
 - Dirty, hazy, damaged or blocked sensor.
 - Radar failure due to interference from other radar sources, such as strong radar reflection in multi-storey car park.
- In complex traffic, the system may be unable to properly respond to the following circumstances:
 - Pedestrians or vehicles move too quickly into the sensor's detection range.
 - Pedestrians are obscured by other objects.
 - Pedestrian outlines are indistinguishable from the surroundings.
 - Pedestrians are not detected, due to, for example, coverage by special clothing or other materials.
 - The vehicle is on a sharp curve.
- Oncoming vehicles:
 - If the system determines that an oncoming vehicle poses a risk of collision, it performs emergency braking automatically. If the accident is inevitable, the system can decrease collision speed.

Precautions

- The AEB system cannot ensure zero collision. In complex traffic, the system cannot always clearly identify all the

vehicles or pedestrians. It may trigger unnecessary warning or braking action for well covers, iron plates or road signs.

- Make sure to drive safely and observe surrounding traffic conditions. The AEB is not a substitute for normal braking operation in any event.
- Do not overly rely on the AEB system as this may result in severe injuries or deaths. The system is only an auxiliary safety tool. The driver must always keep a safe distance from vehicles ahead, control the speed, and be ready to brake or steer away when necessary. The driver must keep control of the vehicle at all times and be fully responsible for safe driving.
- The AEB system is activated only when it exceeds certain speeds. Careful driving is always required, because the system may not be triggered correctly.
- The AEB system cannot work normally when the ESC function is disabled or the fault light is on.
- If PCW gives an alarm, the driver must brake based on traffic conditions to decrease vehicle speed or steer away from obstacles.
- If the vehicle travels too close to the vehicle ahead for too long, a safety distance warning will be given. If the vehicle ahead brakes suddenly, collision may be unavoidable.
- The system will not trigger AEB when the driver is aware of an emergency warning but turns the steering wheel, accelerates or brakes.
- Front mmWave radar sensors may have a transient function failure from limited detection if the vehicle runs under special conditions, such as circular ramps or tunnels, for an extended period. The function can be

recovered by restarting the vehicle or driving on normal roads for a while.

- Sometimes the surfaces of front mmWave radars or the multi-purpose camera are dirty or obscured by foreign objects. In that case, a message is displayed on the instrument cluster and both PCW and AEB are disabled. The functions will return after the sensor is cleaned.
- As the pedestrian protection function is limited by certain physical conditions, the driver must take timely and effective control of the vehicle under dangerous conditions.
- The system cannot completely protect pedestrians or avoid accidents and severe injuries on its own.
- Under certain complex conditions, such as on winding roads, the pedestrian protection function may trigger unnecessary warning or braking.
- System failure may trigger wrong warnings or braking. This may be caused, for example, by the misalignment of the front mmWave radar or multi-purpose camera.
- The brake pedal becomes harder if AEB is triggered. A large amount of hydraulic pressure will be required to push the caliper in a short time and there will be a sizzling noise.
- The AEB system activates only after all doors are closed and all occupants are buckled up. The AEB system will fail to work if:
 - Any door is not closed or it is opened when the vehicle is moving.
 - Any seat belt has not been fastened or it is unfastened while the vehicle is travelling.

- The driver accelerates or decelerates rapidly or turns the steering wheel quickly.
- The vehicle is on a sharp curve.
- System performance may be reduced in the following cases:
 - Strong front bumper impact from accidents or other causes.
 - Improperly inflated or worn out tyres.
 - Unqualified tyres installed.
 - Snow chains installed.
 - Use of a small spare tyre or tyre repair kit.
- Make sure to go to a BYD authorised dealer or service provider for professional calibration of the front mmWave radar or multi-purpose camera in any of the following situations:
 - The front mmWave radar or multi-purpose camera has been removed.
 - Toe-in or rear camber has been adjusted during wheel alignment.
 - The position of front mmWave radars or the multi-purpose camera has changed after a collision.
- Do not attempt to test the AEB system on your own by using objects such as carton, iron plate, dummy, etc. The system may not work properly and thus result in accidents.



WARNING

- PCW and AEB serve as driver assistance functions only, so the driver is fully responsible for driving safety.



WARNING

- Influence of weather, road conditions, and other factors may cause PCW and AEB to fail.
- Use PCW and AEB based on your needs, traffic, and road conditions.

Front Cross Traffic Alert (FCTA) & Front Cross Traffic Braking (FCTB)

Front cross traffic alert (FCTA) and front cross traffic braking (FCTB) detects vehicles crossing the driveway at the front through mmWave radars on both sides of the front bumper to alert the driver and engage the brake if necessary. At low vehicle speeds, when the system detects a risk of collision with a vehicle crossing the driveway at the front, it provides the driver with visual and audible alerts; in the event of an impending collision, the vehicle brakes automatically.

How to Use

- Enable or disable the FCTA and FCTB in infotainment touchscreen →  → **ADAS** → **Active Safety**.
- When FCTA is activated, side mirror warning indicators flash and an audible alarm sounds.
- When FCTB is activated,  is displayed on the instrument cluster and an audible alarm sounds, with AEB automatically braking the vehicle.
- In the event of FCTA/FCTB malfunction,  is displayed.

Precautions

- While the system provides assistance in monitoring front left and right sides, it cannot replace the driver's observation and judgement. The driver must keep control of vehicle at all times and drive properly and is fully responsible for the vehicle.
- When a target vehicle is approaching from the side at a high speed, the FCTA/FCTB system may not be able to provide adequate warning.
- The driver must ensure the normal operation of the system, keeping mmWave radars on both side of the bumper in good condition. For example, dirt, snow, or other obstructions need to be cleared right away.
- In addition, detection may also be affected or delayed by noise or electromagnetic interference.
- Under some circumstances, it is difficult for the system to assist the driver, and detection may be affected or delayed. Possible circumstances include, but are not limited to:
 - The vehicle coming from the side changes the lane suddenly.
 - The target vehicle is obscured.
 - The radar cross section of the target (for example, a bicycle or electric moped) is too small.
 - The vehicle is running under severe weather, such as rain or snow.
 - MmWave radar(s) come off, are loosely installed, or are blocked.
 - The vehicle encounters complex metal guardrails or similar road conditions.
- The system does not work when:

- Targets are outside the mmWave radar's detection range.
- FCTA or FCTB is switched off.
- The vehicle is not in Drive.
- Four doors are open.
- System initialisation has not been complete yet.
- MmWave radars fail.
- Vehicles coming from the front left or right side are detected too late at sharp turns, slopes, or other settings.
- Influence of vibration or collision on mmWave radar sensor calibration can degrade system performance. If this is detected, contact a BYD authorised dealer or service provider.







WARNING

- FCTA/FCTB serves as a driver assistance function only, so the driver must be fully responsible for driving safety.
- Influence of weather, road conditions, and other factors may cause FCTA/FCTB to fail or lead to late braking.
- Use FCTA/FCTB based on your needs, traffic, and road conditions.

Traffic Sign Recognition (TSR)

The Traffic Sign Recognition (TSR) system identifies speed limit signs through the multi-purpose camera and map*, displays such signs on the current road on the instrument cluster, and sends alarm messages to the driver when vehicle speed exceeds the detected limit.

How to Use

- Enable or disable TSR in  → **ADAS** → **Driving Assist** → **Traffic Sign Recognition (TSR)**.
- When the TSR system identifies the current traffic sign,  is displayed on the instrument cluster.
- When TSR cannot identify whether the recognised speed limit value applies to the lane,  is displayed on the instrument cluster.
- When the TSR system experiences reduced performance,  is displayed.
- When the TSR system has a reduced performance and cannot identify whether the recognised speed limit value applies to the lane,  is displayed on the instrument cluster.
- If the TSR system malfunctions,  is displayed on the instrument cluster.
- If you disable TSR manually by pressing buttons,  is displayed on the instrument cluster.
- The specific numbers displayed in the indicators depend on the actual traffic signs.

Precautions

- The traffic sign recognition system can identify speed limit signs only, and will not control speed. The control over the vehicle always vests in the driver. Please drive properly.
- Weight limit signs not in standard size as per national regulations may mistakenly be identified as speed limit signs.
- If a speed limit sign is unclear, distorted, inclined, reflective, or partly blocked or overlaid, the multi-purpose

camera may fail to or incorrectly identify the sign.

- TSR performance depends on weather conditions, lighting, and sign visibility. The system may fail to or incorrectly identify the sign at night or sunset, in rainy, foggy, hazy, snowy or dusty environment, when light is coming from the back of the vehicle, or when there is a sudden change in lighting.
- In case the vehicle has been involved in a collision or the multi-purpose camera's sensor has been reassembled, go to a BYD authorised dealer or service provider for sensor calibration so as to avoid affecting system performance.
- If the model is available on the European market, recognition of traffic jams, construction zones, and accidents ahead must rely on Internet connection and is on the premise that recognition of these signs are supported.

WARNING

- TSR serves as a driver assistance function only, so the driver must be fully responsible for driving safety.
- Influence of weather, road conditions, and other factors may cause TSR to fail or lead to late alarms.
- Use TSR based on your needs, traffic, and road conditions.

Intelligent Speed Limit Control (ISLC)

- The Intelligent Speed Limit Control (ISLC) system integrates ACC and TSR. With ISLC system enabled, if the current ACC speed is inconsistent with

the value on the recognised speed limit sign, the system prompts whether to adjust it to that limit value. The setting is automatically performed after it is confirmed (by toggling down the lever ①).

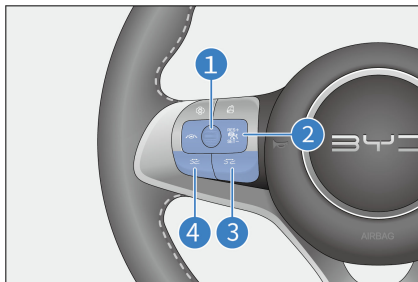

- This function is accessible at the 20-95 mph (30-150 km/h) range of speed.

How to Use

- Enable or disable ISLC in  → **ADAS** → **Driving Assist** → **Traffic Sign Recognition (TSR)** → **Intelligent Speed Limit Control (ISLC)**.
- When the TSR system is disabled, the ISLC switch is greyed out and unusable. ISLC is turned off at this time. The ISLC switch will be usable after the TSR system is enabled again.
- ISLC can be activated provided that ACC is active.

Precautions

- ISLC integrates ACC and TSR. Therefore, ACC and TSR function precautions must be followed during use (see the previous chapters for details).
- ISLC is a driver assistance system, so the driver must keep control of the vehicle at all times.
- ISLC performance depends on weather conditions, lighting, and traffic sign visibility. The system may fail to or

incorrectly identify the sign at night or sunset, in rain, fog, haze, snow or dust, when light is coming from the back of the vehicle, or when there is a sudden change in lighting.

- ISLC integrates ACC and TSR. Therefore, ACC and TSR precautions must be followed during use.

WARNING

- ISLC serves as a driver assistance function only, so the driver must be fully responsible for driving safety.
- Influence of weather, road conditions, and other factors may cause ISLC to fail or lead to late alarms.
- Use ISLC based on your needs, traffic, and road conditions.

Intelligent High Beam Control (IHBC)

Intelligent High Beam Control (IHBC) assesses driving conditions by using the multi-purpose camera sensor and automatically activates or deactivates the high beam accordingly at vehicle speed above 22 mph (35 km/h).

Status Description

- IHBC standby:
 - When the function is enabled but not activated yet,  is displayed on the instrument cluster.
- IHBC activated:
 - With the function enabled, when you set the light switch to the auto lights position, the light meets conditions, and vehicle speed exceeds 22 mph

(35 km/h),  is displayed on the instrument cluster.

- IHBC failure:
 - HMA has failed, and  is displayed.

How to Use

- Enable or disable IHBC in  → ADAS → Driving Assist. When the vehicle is started, the system defaults to previous settings.
- With the function enabled, when you set the light switch to the auto lights position, the light meets conditions and vehicle speed exceeds 22 mph (35 km/h), the system automatically switches between low and high beams based on the current driving environment.

Precautions

- The IHBC system is an auxiliary light control function. While it is recommended to use the system at high vehicle speeds, the system cannot completely replace the driver's judgment. The driver must observe road regulations and actively switch between high and low beams according to road condition changes at all times.
- Beam switching is suppressed if the vehicle is in a high dynamic state, for example when ABS or ESC is activated.
- IHBC system exits when you turn fog lights or turn signals on, set wipers to fast mode, are backing up, or set the light switch to a position other than auto lights, or when the environment has too much lighting.
- Even when IHBC is working, the driver must respond to possible situations where the IHBC is triggered in error or fails to work due to unavoidable

environmental factors and conditions. Typical situations are:

- The driver's stick operation to switch to the high beam is prioritised.
- The weather, such as fog, rain or snow, is extremely terrible for driving.
- There are traffic participants with poor lighting (such as pedestrians and bicycles), railways or waterways nearby, or wild animals on the roads.
- There are strongly reflective objects around, such as traffic signs on motorways and water reflection on the road surface.
- The front windscreen is dirty, covered in mist, or blocked by stickers or decorations.
- In case there is a collision or the sensor has been reassembled, it is recommended to go to a BYD authorised dealer or service provider for sensor calibration so as to avoid affecting system performance.

WARNING

- IHBC serves as a driver assistance function only, so the driver must be fully responsible for driving safety.
- Influence of weather, road conditions, and other factors may cause IHBC to fail.
- Use IHBC based on your needs, traffic, and road conditions.

Lane Departure Assist (LDA)

Lane Departure Assist (LDA) includes lane departure warning (LDW) and lane departure prevention (LDP) functions.

Lane Departure Warning (LDW)



The Lane Departure Warning (LDW) system detects the lane lines ahead through a multi-purpose camera. When the vehicle speed is 38-93 mph (60-150 km/h) and the driver unintentionally drifts out of the lane, the LDW system warns the driver by steering wheel vibration, audible alarm, and an instrument cluster prompt.

Lane Departure Prevention (LDP)

- The Lane Departure Prevention (LDP) system identifies lane lines ahead through a multi-purpose camera. If the driver unknowingly departs from the lane at a vehicle speed between 38 mph (60 km/h) and 93 mph (150 km/h) such that the vehicle is about to roll over lane lines, the system, when activated, slightly turns the steering wheel by providing reverse torque through the electronic power steering (EPS) system to prevent lane departure.
- If LDP system is activated for over five seconds, it gives visual and audible alarms at the fifth second and continues until this activation ends. Warnings include: audible alarm, visual alarm. If the system is activated twice or more within a continued 180-second cycle, the system alarms immediately. For the third activation (and any further ones), alarms are extended by at least 12 seconds.

How to Use

- Enable or disable this function in  → ADAS → Driving Assist → Lane Support System (LSS).
- There are three LDW modes: audible alarm only, steering wheel vibration only, and audible alarm + steering wheel vibration.

- When LDW or LDP is enabled,  is displayed on the instrument cluster.
- When activated, LDW gives alarms (in the form of audible alarm, visual alarm, and steering wheel vibration). On the instrument cluster, virtual lane lines on the side where the vehicle rolls over lane lines turn red.
- When activated, LDP gives alarms (in the form of audible and visual alarms). On the instrument cluster,  flashes twice, virtual lane lines on the side where the vehicle rolls over lane lines turn green.
- In the event of malfunction,  is displayed.

System Limitations

In a complex road traffic environment, the LDA system may detect the lane line incorrectly or fail to detect the lane line. In the following cases, the system may not work or its performance may be significantly degraded:

- Poor visibility on snowy, rainy, or foggy days
- Dirty or fogged front windscreen, or blocked multi-purpose camera
- Glaring from direct sunlight, reflection in puddles, or oncoming vehicles
- Sudden changes in light, such as when the vehicle is entering or exiting a tunnel
- Lane lines obscured by tree shadows on roads in direct sunlight on sunny days.
- Unidentifiable road boundary with grass, soil or kerb.

- To prevent you from being disturbed when the function is activated, it may be depressed if the lane is too narrow.

Precautions

- LDW will be suppressed if a turn signal is used and the vehicle changes lane as indicated by the turn signal.
- LDW may be suppressed if the vehicle travels over lane lines or if lane lines are unclear, too thin, worn, blurred, or covered by dirt/snow.
- LDW may be suppressed if the lane is too wide or too narrow, if the number of lanes increases or decreases, if lane markings change suddenly on ramps or exits, or in situations of complex line arrangements.
- LDW may be suppressed on slopes or winding roads when the vehicle travels too close to the vehicle ahead or when the vehicle ahead obscures lane lines.
- LDW may be suppressed when the vehicle jolts, accelerates or decelerates too quickly, or takes a sharp turn.
- The system operation may be affected if the windscreen within the visual field of the multi-purpose camera is cracked, if the front windscreen glass is dyed or coated in a manner that is not compliant with standards, if any reflective object is placed on the dashboard, or if any other object interferes with camera sight.
- For safety reasons, do not test LDW function on your own. The function will be interrupted if the multi-purpose camera is blocked by any object or exposed to strong lights. The function recovers once conditions return to normal. If it does not, it is recommended to contact a BYD authorised dealer or service provider.

- Disabling the LDW is recommended under any of the following circumstances:
 - Driving in a sporty style.
 - Severe weather conditions.
 - On uneven roads.
- Situations where lane lines may not be identified include, but are not limited to:
 - Unclear lane lines.
 - Incomplete lane lines.
- Situations that may cause recognition difficulty or late function activation of the multi-purpose camera include, but are not limited to:
 - The multi-purpose camera comes off, is loosely installed, or is blocked.
 - The vehicle is running under extreme weather, such as rain, snow, or smog.
 - The multi-purpose camera is partially or completely blocked.

WARNING







- LDA serves as a driver assistance function only, so the driver must be fully responsible for driving safety.
- Influence of weather, road conditions, and other factors may cause LDA to fail.
- Use LDA based on your needs, traffic, and road conditions.

Emergency Lane Keeping Assist (ELKA)

The Emergent Lane Keeping Assist (ELKA) system identifies lane lines ahead through a multi-purpose camera and identifies vehicles approaching from

behind on the adjacent lanes through rear corner mmWave radars. It comes to work within the 32-93 mph (50 km/h-150 km/h) vehicle speed range when the vehicle drifts out of solid lane lines, is about to cross a road edge, or has a risk of colliding with oncoming vehicles or vehicles that are passing it on adjust lines. The system activates EPS system to provide reverse torque, keeping the vehicle in the current lane.

How to Use

- Enable or disable this function in  → **ADAS** → **Driving Assist** → **Lane Support System (LSS)**.
- When ELKA is active,   flashes on the instrument cluster.
- In the event of ELKA malfunction,   is displayed on the instrument cluster.
- If you disable ELKA manually by pressing buttons,  is displayed.

System Limitations

- The ELKA system may detect incorrect or no lane lines in complex traffic. The following situations may lead to failure or performance degradation of the system:
 - Poor visibility on snowy, rainy, or foggy days
 - Dirty or fogged front windscreen, or blocked multi-purpose camera.
 - Glaring from direct sunlight, reflection in puddles, or oncoming vehicles.
 - Sudden changes in light, such as when the vehicle is entering or exiting a tunnel
 - Lane lines obscured by tree shadows on roads in direct sunlight on sunny days.

- Unidentifiable road boundary with grass, soil or kerb.
- To prevent you from being disturbed when the function is activated, it may be depressed if the lane is too narrow.

Precautions

- Situations where lane lines may not be identified include, but are not limited to:
 - Pedestrians, animals, and specialty or specially-shaped vehicles
 - Unclear or incomplete lane lines.
- Situations that may result in detection failure of the multi-purpose camera or late alarms include, but are not limited to:
 - The multi-purpose camera comes off, is loosely installed, or is blocked.
 - The vehicle is running under extreme weather, such as rain, snow, or smog.
 - The multi-purpose camera is partially or completely blocked.
- Situations that may result in detection failure of mmWave radars or late alarms include, but are not limited to:
 - MmWave radar(s) come off, are loosely installed, or are blocked.
 - The vehicle is running under extreme weather, such as rain, snow, or smog.
 - The vehicle encounters certain metal guardrails or similar road conditions.

WARNING

- ELKA serves as a driver assistance function only, so the driver is fully responsible for driving safety.
- Influence of weather, road conditions, and other factors may cause ELKA to fail.

WARNING

- Use ELKA based on your needs, traffic, and road conditions.

Blind Spot Assist (BSA)

- The Blind Spot Assist (BSA) system includes the following functions: blind spot detection (BSD), rear cross traffic alert (RCTA), rear cross traffic braking (RCTB), rear collision warning (RCW), and door open warning (DOW). It detects the environment behind the vehicle through corner mmWave radars installed on both sides of the rear bumper so as to remind the driver of safe driving.

Blind Spot Detection (BSD)*

At vehicle speeds between 10-93 mph (15-150 km/h), if a rear corner mmWave radar detects a vehicle in blind spots on an adjacent lane or a vehicle approaching quickly on the adjacent lane, the indicator on the corresponding side mirror lights up. If the turn signal for the same side is turned on at this moment, the alarm indicator on the side mirror flashes to alert the driver of a risky lane change.

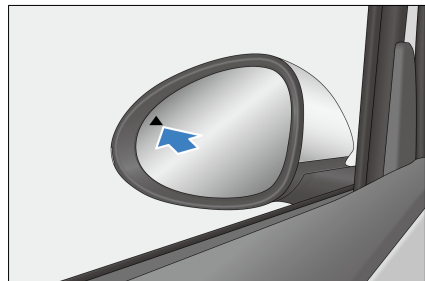

Rear Collision Traffic Alert (RCTA)*

When the vehicle is reversing at a speed no more than 9 mph (15 km/h), the RCTA system detects the vehicles travelling in the blind spot at the back through rear

corner mmWave radars. If the system determines that a vehicle approaching from behind poses a risk of collision, the side mirror warning indicators flash and an audible alarm is given to alert the driver, reducing the possibility of collision.

Rear Cross Traffic Braking (RCTB)*

When the vehicle is reversing at a speed no more than 5 mph (9 km/h), the RCTB system detects the vehicles travelling in the blind spot at the back through rear corner mmWave radars. If the system determines that a vehicle approaching from behind poses a risk of collision, it performs emergency braking automatically.





Rear Collision Warning (RCW)*

At vehicle speeds between 4 mph (5 km/h) and 90 mph (146 km/h), if the rear corner mmWave radar detects a risk of collision with a vehicle approaching quickly from behind on the current lane, the hazard warning light turns on to warn the driver in that vehicle against a possible collision.

Door Open Warning (DOW)*

DOW is realised with rear corner mmWave radars installed on both sides of the rear bumper. When the vehicle is stationary with doors unlocked, the system keeps indicators on side mirrors solid on to warn the driver if moving objects, such as bicycles or automobiles, on an adjacent lane are approaching from behind. At the same time, an icon is displayed on the instrument cluster. If the driver attempts to open the door at this time, indicators on side mirrors begin to flash and a chime sounds.

Cruise Button Operation

- Enable or disable BSD, RCTA, RCTB, RCW, or DOW in  → **ADAS** → **Active Safety** → **Blind Spot Assist**.
- When the blind spot assist system is disabled, no relevant indicators are displayed on the instrument cluster.
- When the blind spot assist system is standing by, if vehicle conditions, such as speed or gear status, do not meet the requirements of any function,  is displayed on the instrument cluster and blind spot assist will not be activated.
- If the blind spot assist system malfunctions,  is displayed on the instrument cluster.
- When the blind spot assist system is active,  is displayed, meaning that the function has been activated and can trigger alarms at any time.

Precautions

- While the BSD system provides assistance in monitoring blind spots of rearview mirrors, it cannot replace the driver's observation and judgement. The driver must keep control of vehicle at all times and drive properly and is fully responsible for the vehicle.
- The BSD system may be unable to provide adequate warning on target vehicles approaching from behind at a high speed.
- The driver must ensure the normal operation of the BSD system, keeping its rear corner mmWave radars in good condition. For example, dirt, snow, or other obstructions need to be cleared right away.
- The BSD system gives a warning if unrelated targets at the rear side or in the rear (such as work zone barriers, large roadside billboards, reflectors in tunnels, or other objects with a large radar cross section) are mistakenly selected as target vehicles.

- Detection may be affected or delayed in some environments. If the radar cross section of the target vehicle is too small (a bicycle, electric moped or pedestrian, for example), the system may fail to identify targets, leading to false alarms. In addition, detection may also be affected or delayed by noise or electromagnetic interference.

System Limitations

- Under some circumstances, it is difficult for the system to assist the driver, and detection may be affected or delayed. Possible circumstances include, but are not limited to:
 - The vehicle coming from behind changes the lane suddenly.
 - Vehicles coming from behind are detected too late at sharp turns, slopes, or other settings.
 - The target vehicle is obscured.
 - Vehicles come from behind at a relative speed above 49 mph (80 km/h).
 - The vehicle is on a curve which is too sharp, or is entering or exiting a curve.
 - The vehicle is running under severe weather, such as rain or snow.
 - Rear corner mmWave radar(s) come off, are loosely installed, or are blocked.
 - The vehicle encounters certain metal guardrails or similar road conditions.
 - Targets that may not be responded include, but are not limited to, pedestrians and animals.
 - The environment contains electromagnetic interference or other influences.

- Vibration or collision influence on sensor calibration of BSD's rear corner mmWave radars can degrade system performance. If this is detected, contact a BYD authorised dealer or service provider.

WARNING

- Blind spot assist serves as a driver assistance function only, so the driver must be fully responsible for driving safety.
- Influence of weather, road conditions, and other factors may cause blind spot assist to fail.
- Use blind spot assist based on your needs, traffic, and road conditions.

Driver Attention Warning (DAW)

Driver attention warning (DAW) system evaluates the driver's degree of fatigue by the vehicle operation status such as steering wheel angle, break, gear and lane-changing. The driver would be alerted by popups and voice prompt according to the evaluation results to ensure driving safety.

Driver Attention Warning (DAW) is enabled by default when the vehicle is powered on.

How to Use

With the vehicle powered on, set the warning in infotainment touchscreen → Vehicle Control  → Vehicle Settings → Cabin Perception → Driver Attention Warning (DAW). For safety considerations, the setting is valid on the current trip only and will revert to the default mode on the next trip.

 **WARNING**

- The driver should pull over the vehicle as soon as possible when feeling tired.

 **CAUTION**

- The driver attention warning system is only an auxiliary system and is not capable of effective recognition and alarm-raising in all situations. It cannot completely replace the driver's subjective observation and judgment. The driver must maintain control of the vehicle at all times, complying with all road laws and regulations, and taking full responsibility for the vehicle.

Child Presence Detection (CPD)

After the vehicle is powered off, child presence detection is performed if any door is opened and then all doors are closed or locked. If child presence is detected, an alarm is given in the form of light flashing and honking. The A/C will be switched on soon after. To cancel the alarm, unlock or open any door.

How to Use

Access this function in the infotainment touchscreen  → **ADAS** → **Driving**

Assist. Three options are provided: **OFF**, **ON**, and **Delay**.

- By default, the system is switched on each time when the vehicle is just powered on.
- Tap **OFF** to deactivate the alarm in this trip.

- Tap **Delay** to extend the alarm (for five minutes) in this trip.
- Tap the exclamation mark for more details.

System Response

- If life presence is detected, the initial alarm (light flashing and honking) starts within 10 seconds and will last for about six seconds.
- If not cancelled, the alarm (light flashing and honking) escalates within 90 seconds and will last for about 25 minutes.
- The A/C will be switched on three minutes after alarm escalation if it is not cancelled, and will keep running for about 30 minutes.

 **WARNING**

- While light flashing, honking, app message prompts, and A/C operation reduces the harm to the children in the vehicle, they cannot completely prevent harms.
- When a reminder is provided, check whether any child has been locked inside the vehicle promptly to avoid further harms.

 **CAUTION**

- Misidentification or false alarm could happen.
- The alarm may be given for adults, children, pets, or other lives detected.
- The alarm cannot be cancelled by unlocking the vehicle from the app.
- The system may not be able to trigger an alarm or switch



CAUTION

on the A/C if the SOC is low. Keeping the vehicle at high SOC is recommended.

Tyre Pressure Monitoring

Direct Tyre Pressure Monitoring

- The direct tyre pressure monitoring system is an auxiliary system that monitors tyre pressure in real time to improve vehicle safety and comfort and reduce tyre wear and energy consumption due to insufficient tyre pressure.
- Access the instrument cluster menu by pressing the  button on the steering wheel, then select the tyre pressure screen using the scroll button.

Tyre pressure system alarm

- When the pressure of any tyre is lower than 80% of the standard tyre pressure and the system is running, the tyre pressure fault warning light lights up and the tyre pressure value turns yellow. In that case, it is recommended to check for slow air leakage and inflate the tyre to the correct pressure value.
- When the temperature of any tyre is above 185 °F (85°C) for three consecutive minutes, the tyre pressure system gives a high temperature alarm, and the temperature value of the corresponding tyre turns yellow. You are then recommended to stop the vehicle and wait for the tyre temperature to decrease before further driving.
- When the system is running, if a fault occurs, the tyre pressure fault warning light flashes and then becomes solid on, and the message

"No Signal" or "Please check TPMS" is displayed on the instrument cluster. In that case, check the tyre pressure monitoring module, and check for any surrounding electromagnetic source nearby. If the alarm persists for a long time, please contact a BYD authorised dealer or service provider.



WARNING

- The system does not stop vehicle traveling in the event of abnormal tire pressure. Therefore, each time before driving, start the vehicle statically to check whether the tire pressure meets the requirements specified by the manufacturer. If not, do not drive, otherwise vehicle damage or personal injury can occur.
- If pressure is found to be abnormal while driving, check the tyre pressure immediately. If the low pressure warning light comes on, avoid sharp turns or emergency braking, and reduce vehicle speed, pull it over to the kerb and stop as soon as possible. Driving with low tyre pressure can cause permanent damage to tyres and increase the likelihood of tyre scrapping. Serious tyre damage can lead to traffic accidents, resulting in serious injuries or deaths.



CAUTION

- The running time of the tyre pressure monitoring module is related to the daily travel distance and other factors.
- The monitoring module regularly transmits tyre pressure and other information to the display. Therefore, if the tyre pressure



CAUTION

- drops suddenly or there is a flat tyre, the monitoring module will not transmit data to the display until the next monitoring. In this case, the vehicle may be out of control. If there is a flat tyre and monitoring fails to inform, or if you feel that there are some tyre problems, stop driving immediately instead of waiting for the display to signal an alarm.
- Incorrectly installed monitoring module affects the air tightness of the tyre. It is recommended that the installation and replacement of the pressure monitoring module be carried out by professional technicians of a BYD authorised dealer or service provider in accordance with the requirements of the installation manual.
 - Since tyre pressure varies with regional temperatures, inflate or deflate the tyres according to the values displayed on the instrument cluster and the standard tyre pressure values.
 - The tyre pressure monitoring system may be disturbed by non-BYD approved electrical accessories on the vehicle. This is not a tyre pressure system failure.
 - The tyre pressure system needs to be matched again after replacement of wheel rims or spare tyres* or tyre rotations. Please go to a BYD authorised dealer or service provider to re-match the tyre pressure.

Acoustic Vehicle Alerting System (AVAS)

The Acoustic Vehicle Alerting System (AVAS) refers to the broadcast to pedestrians near the vehicle when it is travelling at low speed.

- When driving forward:
 - The broadcast volume increases with vehicle speed in the range of $0 \text{ mph} < V \leq 12 \text{ mph}$ ($0 \text{ km/h} < V \leq 20 \text{ km/h}$).
 - The broadcast volume decreases with vehicle speed in the range of $12 \text{ mph} < V \leq 18 \text{ mph}$ ($20 \text{ km/h} < V \leq 30 \text{ km/h}$).
 - At speeds above 19 mph (30 km/h), the broadcast sound stops automatically.

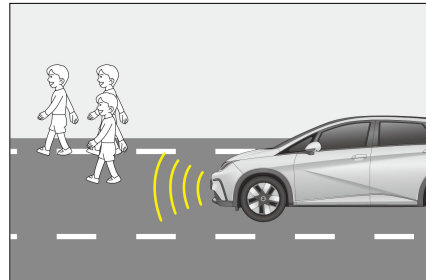

- The vehicle makes a continuous and balanced prompt sound when moving in reverse.

How to Use

By default, the system is switched on each time when the vehicle is powered on. AVAS has two sound sources: standard and brand. To choose a sound source, go to  → **Vehicle Settings** → **Notification**.

! REMINDER

- If the AVAS prompt sound cannot be heard when driving at a low speed, stop the vehicle in a relatively safe and quiet place, open a window, then drive in R gear and check whether you can hear an audible prompt from the front of the vehicle. If it is confirmed that there is no sound, contact a BYD authorised dealer or service provider to deal with it.

Panoramic View System

With the ignition switched on, tap **Vehicle View** on the infotainment system homepage or press the  button on the steering wheel to access the panoramic view.

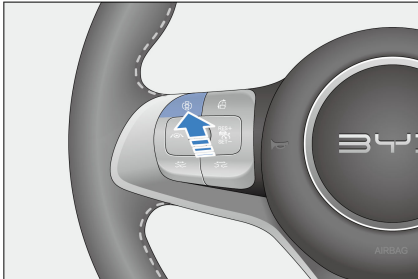

- Landscape mode:
 - Tap the front, rear, right, or left area of the vehicle icon on the right. View of the selected area is displayed in the image section on the left.
 - In the single front and rear views, double-tap the image section to switch to a 180° perspective displayed in full screen.

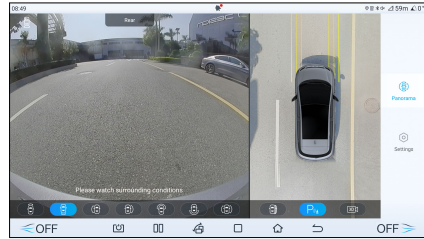

- Tap the radar icon  in the panoramic view to enable the radar display, and tap it again to disable. When the radar display is enabled, a warning is displayed as the vehicle is approaching an obstacle.
- Portrait mode:
 - Tap any two of the front, rear, right, and left areas of the vehicle icon in the lower left section. Views of the two selected areas are displayed in the upper and lower right image section.
 - Tap the vehicle image switching button in the lower left corner to switch between transparent and nontransparent vehicle images.
 - After the vehicle starts, the image before last power-off is displayed on the transparent panoramic view screen. Foreign bodies shown may be inconsistent with the actual ones in the underbody and surrounding blind areas. The underbody image update will begin only after the vehicle has started to run and will be complete when the vehicle has been driven beyond its length.

! WARNING

- The panoramic view system can provide transparent panoramic view to show the image below the vehicle. This function is only for assisting in observation of area below the vehicle during parking/

WARNING

driving. Investigation of foreign objects below the vehicle and dangerous situations should be carried out in any other manner to ensure the safety of personnel and the vehicle.

- When the vehicle runs at a low speed, the transparent panoramic view function is affected by speed fluctuation or multiple stops, so there will be misalignment between the images below the vehicle and that outside the vehicle.
- The panoramic view system is only to be used for parking/driving assistance. It is not safe to rely solely on this system to park or drive the vehicle, because there are some blind spots in front of and behind the vehicle. The surroundings of the car should be observed in other ways during the parking/driving process, so as to avoid accidents.
- This system uses wide-angle fisheye cameras, so the object on the display screen may appear somewhat deformed in comparison with the actual object.
- When the side mirrors are not extended in place, do not use the panoramic view system; and when the panoramic view system is used for parking/driving, ensure that all the car doors are closed.
- The distance to an object displayed on the panoramic view screen may be different from the distance perceived subjectively, especially when the object is closer to the vehicle. Assess the distance in various ways.

WARNING

- Cameras are installed above the front grille, side mirrors, and the rear license plate. Make sure the cameras are unobstructed.
- To prevent affecting camera performance, avoid spraying directly on the cameras when washing the vehicle body with high-pressure water. Wipe any water or dust off the camera in time.
- Protect the cameras from any impact to prevent damage or malfunction.
- After the vehicle is powered on, if you press the panoramic view start button or shift into reverse while the infotainment system is not fully activated, the output on the panoramic view screen will be delayed or the screen will flash. This is a normal part of the camera power-on process.
- When one or more cameras in the system are not working, the corresponding views go black.
- When no camera is available, a "No video signal detected" message is displayed.

Parking Assist System

- During vehicle parking, the parking assist system detects obstacles by sensors, and prompts the driver with the proximity of obstacles by an image on the infotainment touchscreen* and a speaker alarm.
- The parking assist system helps with reversing. Pay attention to the environment behind and around the vehicle during reversing.

WARNING

- With the vehicle in Drive, the operation of the parking assist system ceases when vehicle speed rises to about 7 mph (11 km/h) and resumes when vehicle speed drops to about 6 mph (10 km/h).
- Do not place any articles within the sensors' working range.
- To prevent sensor malfunction, do not wash the sensor area with water or steam.

Reversing Radar Switch

- Turn the reversing radar system on or off in infotainment touchscreen →  → **ADAS** → **Parking Assistance** → **Parking Sensors**.
- When the ignition is switched on and EPB is released, the parking assist system is enabled automatically.
- When enabled, the system raises an alarm if obstacles are found surrounding the vehicle; when disabled, it does not.

Sensor Type

- When the sensor detects an obstacle, an image is displayed on the infotainment touchscreen* according to the location of the obstacle and its distance from the vehicle.

- When the driver conducts parallel parking or reverse parking, the sensor measures the distance between the vehicle and the obstacle and communicates this information through the infotainment touchscreen and the speaker. Be aware of the surroundings when using this system.

- ① Front right corner sensor*
- ② Front left corner sensor*
- ③ Rear right corner sensor
- ④ Rear centre sensor
- ⑤ Rear left corner sensor

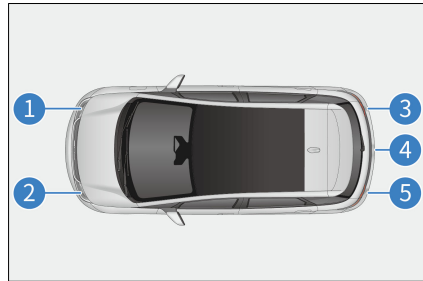



Distance Display Alarm

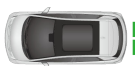

When the sensor detects an obstacle, the location of the obstacle and its approximate distance from the vehicle are displayed on the infotainment touchscreen, and the speaker beeps.

Working example of centre sensors

Approximate Distance	Touchscreen Display Example	Alarm Sound
About 28~47 in (700~1,200 mm)		Slow

Approximate Distance	Touchscreen Display Example	Alarm Sound
About 12~28 in (300~700 mm)		Fast
About 0~12 in (0~300 mm)		Continuous

Working example of corner sensors

Approximate Distance	Touchscreen Display Example	Alarm Sound
About 12~24 in (300~600 mm)		Fast
About 0~12 in (0~300 mm)		Continuous

Working Sensors and Detection Range

All sensors are activated upon reversing.

The illustration shows the sensors' detection range. Sensors have a range limitation, so drivers must check the surroundings before slowly reversing the vehicle.

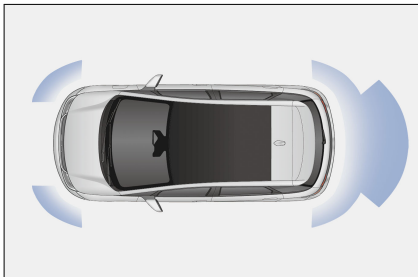

Error Message

Failure of the parking radar system is indicated by a message on the instrument cluster and a beep.

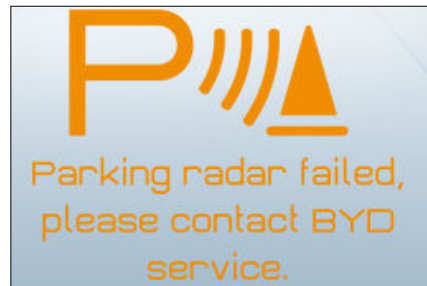

WARNING

- The sensors may fail to detect obstacles that are very close to the vehicle.

WARNING

- The parking assist system is only for assistance, and is not a substitute for personal judgment. Be sure to operate the vehicle based on your observations.
- Sensors will not work properly if accessories or other objects are placed within their detection range.
- In some cases, the system cannot operate properly and will fail to detect certain objects as the vehicle approaches them. Therefore, be sure to observe the vehicle's surroundings at all times. Do not rely solely upon the system.
- Failure of the parking radar system is indicated by the message "  Parking radar failed, please contact BYD services." on the instrument cluster and a beep. In that case, it is recommended to contact a BYD authorised dealer or service provider for inspection as soon as possible.

Sensor Detection Information

- Certain vehicle conditions and surroundings may affect the sensors' ability to accurately detect obstacles. Detection accuracy may be affected if:
 - There is dirt, water or fog on the sensor.
 - There is snow or frost on the sensor.
 - The sensor is masked in any way.
 - The vehicle leans significantly to one side or is overloaded.
 - The vehicle is moving on particularly bumpy roads, slopes, gravel or grass.
- The sensor has been repainted.
- The vicinity is noisy due to honking of vehicles, motorcycle engines, air brakes of large vehicles, or other noises that produce ultrasonic waves.
- There's another vehicle with parking assist system nearby.
- The vehicle is fitted with a tow eye.
- The bumper or the sensor was hit hard.
- The vehicle is approaching a high or zigzag curb.
- The vehicle is driving in the sun or in the cold.
- The vehicle is fitted with non-original, lower suspension.
- Except as described above, sensors may not be able to correctly determine the actual distance due to the shape of the object.
- The shape and material of obstacles may prevent sensors from detecting them, especially the following:
 - Electric wires, fences, and ropes
 - Cotton, snow, and other materials that absorb radio waves
 - Any object with sharp edges and corners
 - Low obstacles
 - High obstacles facing outwards towards the vehicle
 - Any object under the bumper
 - Any object close to the vehicle
 - Persons near the vehicle (depending on the type of clothing)
- If an image is displayed on the infotainment touchscreen* or there is a beep, it may be that the sensor detects

an obstacle or is interfered. If the issue persists, go to a BYD authorised dealer or service provider for inspection.



CAUTION

- To prevent sensor malfunction, do not rinse or apply steam to the sensor area.

Driving Safety Systems

For better driving safety, the following driving safety systems works automatically based on driving conditions. However, these systems only provide assistance, and excessive reliance on them is not recommended.

Intelligent Power Braking System

The intelligent power braking system is an advanced decoupled electro-hydraulic braking system, incorporating vacuum booster, electronic vacuum pump, and ABS/ESC functionality. The system assists vehicle braking according to the driver's demands. It offers advanced control functions such as ABS, electronic brake force distribution (EBD), traction control system (TCS), vehicle dynamic control (VDC), comfort parking (CST), hill-start hold control (HHC), hydraulic brake assist (HBA), and controlled deceleration for parking brake (CDP) to improve vehicle stability and comfort, and the recovery efficiency of brake energy.

Vehicle Dynamics Control (VDC)

When the vehicle turns suddenly while running, the VDC system determines the driver's intention based on such information as steering wheel's angle and vehicle speed, and continuously compares with the actual condition. If the vehicle swerves from the normal lane, the VDC corrects the situation by engaging brakes to the corresponding

wheels to help the driver control skidding and maintain directional stability.

Traction Control System (TCS)

TCS prevents the drive wheels from skidding during acceleration by reducing the motor power, and, when necessary, applies braking forces to prevent drive wheels from spinning. It makes it easy for the vehicle to start, accelerate, and climb under adverse driving conditions.



WARNING

- TCS may not work effectively in the following situations:
 - On slippery roads, even if TCS is working properly, it may not be able to control the direction and meet power requirements.
 - Do not drive in conditions where the vehicle may lose its stability and power.

Hill Descent Control (HHC)

After you release the brake pedal, HHC maintains the brake pressure you imposed for 1.5 seconds to prevent backward sliding of the vehicle.

Hydraulic Brake Assist (HBA)

When you press the brake pedal quickly, HBA detects that the vehicle is in emergency condition. It quickly increases the brake pressure to the maximum so that ABS can intervene more quickly and shorten the braking distance effectively.



Controlled Deceleration for Parking Brake (CDP)

When you engage the EPB, the CDP function starts working so that the vehicle brakes at a constant deceleration (0.4 g if EPB is engaged but the brake pedal is not pressed, and 0.8 g if EPB is engaged and the brake pedal is pressed) until the

vehicle stops. The function stops working when the EPB is released.

Electronic Stability Controller (ESC) operation instructions

Intelligent power braking system has the following new functions compared with the original ESC system:

- Brake assist mode
 - The brake assist mode is used to adjust the brake pedal feel. The relation curve between the brake pedal depth and the vehicle deceleration varies across different modes for the driver to choose their preferred pedal feel.
 - You can select a mode in infotainment touchscreen →  → Vehicle Settings → Smart Chassis.
- Comfort Parking (CST)
 - Comfort parking function: When the vehicle decelerates to stop in a non-emergency situation, the integrated brake control system reduces the stop-instant suspension pitch and impact by controlling the brake pressure of the four brakes, providing a smooth stop feeling for the driver.
 - Enable or disable this function in infotainment touchscreen →  → Vehicle Settings → Smart Chassis.
 - After the function is triggered, the braking distance may increase by 0.8-2 inches (2-5 cm). Increase the distance from the vehicle or obstacle ahead accordingly before stopping your vehicle.
- Brake disc wiping
 - Water on the brake discs increases the braking response time. The brake disc wiping function removes moisture during driving in wet environments. This is achieved by

actuating the brake at low pressure, keeping the brake pads in contact with the rotating brake discs. Moisture is thus wiped off the discs. When the system detects rain or wet roads, it repeatedly wipes the brake disc at certain intervals.

- ESC working
 - If there is a risk of skidding or backsliding when the vehicle starts on a slope, or if either drive wheel is spinning, the ESC indicator flashes to indicate that ESC system is working.
- Disabling ESC
 - If the vehicle gets stuck in snow or mud, ESC may reduce power output from the motor to the wheels, where the system should be turned off to get out of the jam.
- Turning off ESC
 - Press the ESC OFF button or go to infotainment touchscreen →  → **ADAS** → **Active safety**. ESC also checks its operating status in real time. If you turn off ESC while it is working, it completes the active intervention control rather than executes the "shutdown" command immediately. ESC is disabled only after the intervention control is complete.

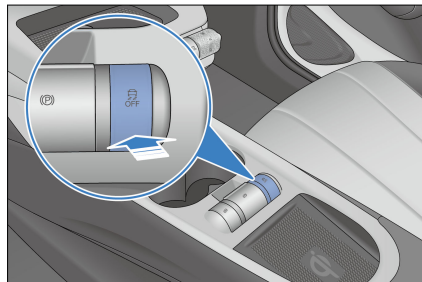

- Some ESC functions may be re-enabled if you press the ESC OFF switch again or the vehicle speed

exceeds the threshold of 50 mph (80 km/h). In order to prevent ESC from being turned off suddenly, ESC can be activated again only when it is not in a vehicle dynamic intervention state.

- ESC OFF switch mis-operation
 - ESC is considered to be mis-operated if the ESC OFF switch is pressed and held for more than 10 seconds. In that case, all ESC functions remain in normal operation.
- Restarting ESC after the vehicle is powered off
 - When the ESC system has been turned off, restarting the vehicle automatically restarts the system.
- ESC start and speed linkage
 - Although already turned off, the ESC system can start on its own if the vehicle becomes extremely unstable as the speed increases to above the threshold of 50 mph (80 km/h).
- When ESC system is activated
 - If the ESC fault indicator  flashes, drive with extra care to avoid accidents. Exercise additional caution when the indicator is flashing.
- When ESC system is disabled
 - Be careful when ESC is disabled, and drive at speeds suitable for road conditions. The ESC system ensures vehicle stability and its driving force. Never turn it off unless necessary.
- Replacing tyres
 - Make sure all tyres are of the same size, brand, tread pattern, and total load. In addition, be sure to inflate tyres to the recommended pressure.

- Neither ABS nor ESC will work properly if the vehicle is fitted with different tyres.

- For details on tyre or wheel replacement, it is recommended to contact a BYD authorised dealer or service provider.

- Tyre and suspension handling

- The use of any defective tyre or modified suspension affects the driving safety system and may cause the system to fail.

Multi-collision braking*

- If an accident requires airbags activation, the vehicle engages automatic braking.
- Speed reduction, along with intervention by additional driving systems (ESC and ABS), assists the vehicle to maintain stability and lane position.
- Hazard and brake lights also light up to alert oncoming traffic and prevent further collisions.
- To support emergency service rescue and vehicle recovery, brakes will release and brake lights will go off after the accident.
- The driver can interrupt the multi-collision braking* at any time by accelerating or braking.

Anti-lock Braking System (ABS)

- The Anti-lock Braking System (ABS) hydraulic system has two separate circuits, each running diagonally through the vehicle (left front wheel brake connected to the right rear wheel brake). If one circuit fails, two wheels can still be braked.
- ABS helps maintain the steering control by preventing the wheels from locking or skidding when brake

is engaged suddenly or on slippery roads.

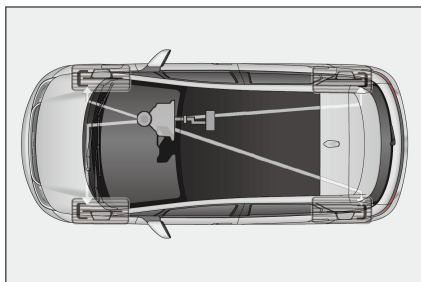

- When the front tyres skid, there is no steering control, which means that the vehicle still moves forward even though the steering wheel is turned. ABS helps prevent locking and maintain steering control since pulsating prompt brake is much faster than human reaction.
- Never pulsate the brake pedal; otherwise, ABS may malfunction. While steering away from danger, a firm and steady pressure should always be maintained on the brake pedal for the ABS to work.
- When the ABS is working, the brake pedal will vibrate, which may produce noise. This is normal because the ABS is pulsating the brake quickly.

Electronic Brakeforce Distribution (EBD)

- The EBD is an auxiliary function of ABS. Before ABS acts, if the skid rate of rear wheel is high, ABS adjusts the brake pressure of rear wheel for a smoother and more ideal brake force distribution.

WARNING

- ABS cannot work effectively under the following conditions:

WARNING

- Tyres with inadequate grip are used (for example, excessively worn tyres used on snow-covered roads).
- The vehicle skids when driving at a high speed on slippery roads.
- ABS is not designed to reduce the braking distance of the vehicle. Always keep a safe distance from the vehicle ahead on:
 - Muddy, sandy, or snowy roads.
 - Roads with potholes or uneven roads.
 - Bumpy roads.

CAUTION

- If the ABS fault warning light is still on while the braking system warning light is on, immediately park the vehicle in a safe place. It is recommended to contact a BYD authorised dealer or service provider.
- In this case, if brakes are applied, the ABS will not work and the vehicle will become extremely unstable.
- ABS does not reduce the time and distance required to stop the vehicle. This device only helps you control steering when braking. Please always keep a safe distance from other vehicles.
- ABS cannot prevent skidding caused by sudden direction change, such as trying to make a sharp turn or change lanes suddenly. Always drive carefully at

CAUTION

a safe speed, regardless of road and weather conditions.

- ABS does not prevent decrease in stability either. When applying the brake in an emergency, the steering should be moderate. A large or sharp turn during the driving can cause the vehicle to swerve into oncoming traffic or run off the road.
- When running on soft or uneven surfaces (such as gravel or snow), a vehicle with ABS may require a longer braking distance than a vehicle without ABS. In such cases, slow down and keep a long distance from other vehicles.

Other Main Functions

Interior Rearview Mirror

Manual Anti-glare Function

The interior rearview mirror can be adjusted to two positions, suitable for day and nighttime respectively. The nighttime position reduces glare from vehicles to the rear.

- Daytime driving - turn the control lever to position ①, in which the image in the interior rearview mirror is the clearest.
- Nighttime driving - turn the control lever to position ②, which reduces the disturbance from headlight beams from vehicles to the rear at night. Be aware that this glare reduction also reduces the clarity of the rear view.

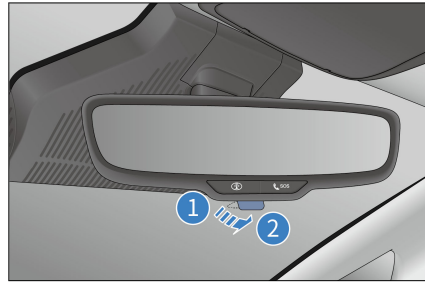

Adjusting the Rearview Mirror Manually

Move the interior rearview mirror up or down, left or right to a suitable position.

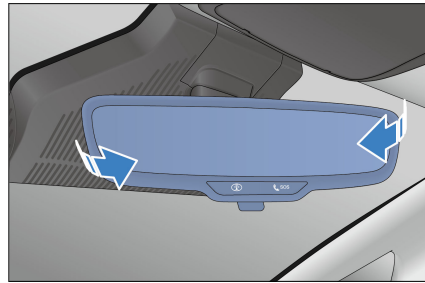



WARNING

- Adjusting the rearview mirror before driving. Do not adjust the rearview mirror while the vehicle is in motion, as it may distract the driver's attention, causing personal injury or death from accidents.
- Do not hang heavy objects from the interior rearview mirror, or shake or drag it with force.
- When manually adjusting the interior rearview mirror, do not forcibly adjust the stuck mirror to avoid the mirror falling off.

Side Mirrors

Side Mirror Adjustment

Use the associated switches to adjust the side mirrors to see the sides of the vehicle using.

- Selection switches: used to select the side mirror to be adjusted.
 -  : Left side mirror button
 -  : Right side mirror button
- Side mirror adjustment buttons  : Select the side mirror to be adjusted, and press this button to adjust the side mirror lens to a right position.

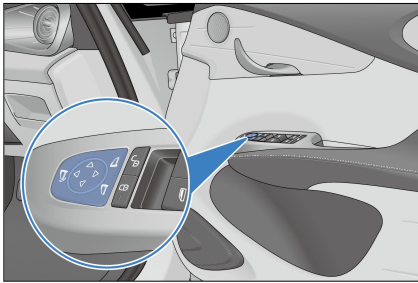

Folding Side Mirrors

Enable or disable the side mirror auto-fold* in infotainment touchscreen →  → External Mirrors.

- Press the  button to fold the side mirrors with power. Press the button again to unfold the mirrors.
- Both side mirrors fold automatically* when the anti-theft alarm system is armed, and extend automatically when the system is disarmed.

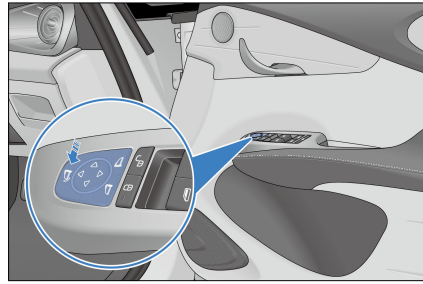

Wipers

Check front and rear wiper blades for cracks or partial hardening at least every six months or 6,214 miles (10,000 km). If they are noted, replace wiper blades. Otherwise, the windscreen will streak or will be left unclean after wiping.

Configuration 1

1. Pull up the wiper arm at the driver side, and then pull up the other at the passenger side.
2. Press the wiper lock button.

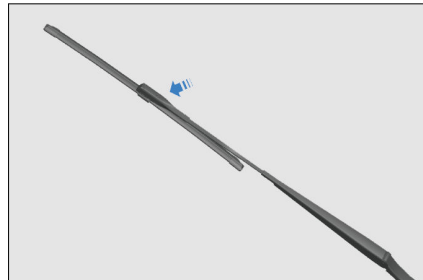

3. Hold the wiper blade and pull it out along the indicated direction.
4. When installing a new wiper blade, follow the reverse procedure.

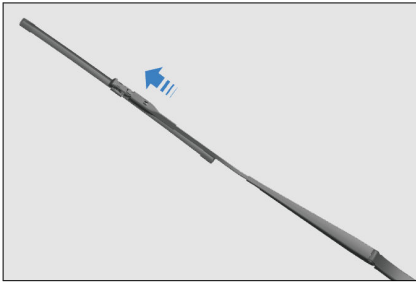

Configuration 2

1. Pull up the wiper arm at the driver side, and then pull up the other at the passenger side.
2. Move the rear wiper blade to the position as shown.
3. Press the lock button, push the blade in the direction of the arrow until it fully separates from the hook, and twist it to take it out.
4. When installing a new wiper blade, follow the reverse procedure.

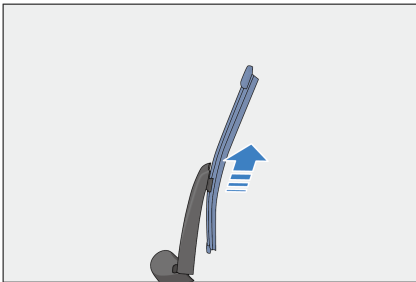

CAUTION

- Handle wiper blades with care. Do not push the wiper arm to let the wiper blade straightly strike onto the windscreen.
- Do not bend the wiper blade, and do not obstruct the wiper blade when the wiper is in operation.

Snow Chains

- Snow chains are only for emergencies or areas where they are permitted by laws.
- Snow chains should be installed on front wheels. Be careful when driving the vehicle installed with snow chains on snow-covered roads. Use thin snow chains. Some snow chains may damage tyres, wheels, and the vehicle body. The recommended snow chains are no larger than 0.24 in (6 mm) in thickness or diameter, which provides enough space between tyres and other parts in the hubcap.
- Read the component assembly drawings and other instructions provided by the snow chain manufacturer carefully.
- Before purchasing and installing snow chains, consult a BYD authorised dealer or service provider where your vehicle was purchased.
- In order to minimise wear of tyres and snow chains, do not travel with snow chains on roads without snow.

REMINDER

- Driving speed must not exceed 19 mph (30 km/h) or the speed limit specified by the snow chain manufacturer.
- Drive carefully, paying attention to bumps, potholes, and sharp turns that can cause the vehicle to bounce.
- Install the chains symmetrically and remove them immediately after driving on snowy or muddy roads.
- For vehicles with snow chains, avoid sharp turns or braking with



REMINDER

locked wheels, and slow down the vehicle before entering a curve to avoid accidents due to loss of control.

- If an abnormal sound is heard from the snow chain, please stop the vehicle immediately to check whether the vehicle components such as suspension, body or brake lines are normal, and ensure that there is no contact between them and the snow chains.
- Do not install snow chains with low tire pressure.

05

IN-VEHICLE DEVICES

Infotainment System.....	140
A/C System.....	142
BYD App.....	146
Storage.....	147
Other Devices.....	149

Infotainment System

Infotainment Touchscreen

When the ignition is on, the initial screen is displayed for several seconds and the infotainment system starts to work. To better experience infotainment functions, such as apps and Internet calls, the system must be used after network connection.

① Infotainment touchscreen

② Scroll button

- Scroll up to turn volume up or down to turn volume down. Volume ranges from 0 to 39. A mute icon is displayed when volume is 0.
- Press the scroll button to mute the sound and enter the screen saver screen or turn off the screen (set the screen saver through the infotainment touchscreen → **System Settings** → **Display**). Press the scroll button again to turn off the mute and turn on the screen.
- Press and hold the scroll button for three seconds to restart the infotainment system.

Reset to factory settings

- This function factory resets the infotainment system.
 - During the process, do not touch any infotainment button or turn off the power supply, or errors may occur.
 - The process takes two to five minutes, please wait patiently.

WARNING

- Do not use a high-power inverter in the vehicle, as this may cause infotainment system malfunction.
- Do not format or root the device without authorisation, as this may cause infotainment system or vehicle malfunction.
- In driving, please use the infotainment system in landscape mode whenever possible for your safety.

CAUTION

- To prevent damage to the touchscreen:
 - Touch the screen gently. If there is no response, remove finger from the screen, then touch it again.
 - Clean the screen with a soft damp cloth. Do not use any detergent.
- Using the touchscreen
 - When the screen temperature is low, the image displayed may be darker or the system may work slightly slower than normal.
 - The screen may be dark or difficult to see when you are wearing sunglasses. In that case, change the viewing angle or take off the sunglasses.
 - Touchscreen buttons that are greyed out cannot be operated.
- The touchscreen interface shown here is for reference only.

Navigation Bar

Navigation Bar

Gestures and Responses

Gestures and associated system responses are:

- Tapping: opens applications, selects functions, clicks icons on the touchscreen, or types characters.
- Dragging: touching and dragging an icon, thumbnail, or preview to the target position to change its location.
- Swiping: operational on homepage and app screens.
- Double-tapping: zooms in or out an image.
- Spreading/pinching: zooms in or out an image with two fingers.

OTA Update

- The vehicle can be updated over the air(OTA) . You can update the infotainment system by tapping  → **System Settings** → **Version** → **Software Version**.
- When available, new updates are prompted on the infotainment touchscreen. You can update immediately when the new version is available or schedule an update based on your vehicle usage.

CAUTION



- Do not move the vehicle during the update.
- Before the update, ensure that the vehicle is parked safely in Park gear with network connection successfully established.

CAUTION

- Ensure the vehicle has a high SOC before starting the update.
- Do not install any third-party devices in the OBD interface port before or during the update.
- Do not charge or discharge the vehicle during the update.
- No operations can be performed during the update progress except the following situations: locking/unlocking the vehicle with smart key, locking/unlocking the vehicle with microswitch, turning on/off the interior lights, lighting up the hazzard warning light or rolling up/down the windows.
- If the update fails, try rerun it and contact a BYD authorized dealer if it still fails.

BYD Assistant

BYD Assistant is an intelligent voice assistant that responds to your voice commands, such as requesting navigation, playing music/radio, making a phone call, and controlling in-vehicle devices.

- Waking up BYD Assistant:
 - On the steering wheel, press the  button.
 - On the infotainment touchscreen, tap .
 - Say the wake-up word: "Hi, BYD."
- Your voice commands can be recognised after system wake-up.
- Give any instructions.
 - This may be "Go home" (shortcut locations set), "Play music", "Make

a call" (contacts data and Bluetooth connection required), "Set the temperature to 23°C", or "Turn on the seat ventilation for the driver". BYD Assistant then performs the recognised instruction.

Bluetooth Call

Bluetooth Call

File Management

文件管理器

A/C System

A/C Buttons

- ① AUTO
- ② Front windscreen defroster button
- ③ A/C ON/OFF

REMINDER

- Remote A/C activation:
 - You can switch on the A/C by using the smart key or the BYD Cloud Service app to create a comfortable vehicle interior environment in advance.

A/C Operation Interface



- | | | | |
|---|----------------------------|----|--|
| 1 | A/C setting | 9 | Defroster for rear windscreen & side mirrors |
| 2 | Seat heating* | 10 | Circulation mode |
| 3 | A/C operation interface | 11 | Ventilator |
| 4 | A/C ON/OFF | 12 | Front passenger's temperature control button |
| 5 | Auto mode | 13 | Air distribution |
| 6 | Cooling | 14 | Fan speed control |
| 7 | Max cooling | 15 | Driver's temperature control |
| 8 | Front windscreen defroster | | |

A/C Function Definitions

Auto mode

- Tap this button to automatically adjust compressor state, fan speed, and air outlet mode. The button indicator (on the gear shift control panel) lights up.
- When the fan speed, air outlet mode, or compressor state is set, the fully-

automatic control mode is deactivated, but functions other than those set remain in automatic mode.

A/C ON/OFF

- When the A/C is on, press this button to turn the A/C off.
- When the A/C is off, press this button to turn the A/C on.

Fan speed control

- Tap the chosen position. The more bars illuminated, the faster the fan speed.

Front windscreen defroster

- Tap this button to enter the front windscreen defrost mode, distributing air to the front windscreen and side windows. Tap this button again to exit this mode.
- Tapping this button activates windscreen defrosting and demisting and turns the A/C on.

Temperature control button

- To increase/decrease the temperature, tap the upper/lower arrow on the screen, or touch the temperature display area and then swipe downwards/upwards.
- "Lo"/"Hi" is displayed when the temperature is set to the lowest/highest value.

Max cooling

- Tap this button to activate the max cooling control. The temperature is set to "Lo", the fan speed is set to the maximum, the recirculation mode is activated, and air blows in face level mode.
- Tap this button again to exit.

Cooling

- Tap this button to turn on the A/C. The icon lights up and cooling begins. Tap this button again to turn off the A/C. The icon goes out.

Circulation mode

- Tap this button to switch to recirculation/fresh air mode. Tap it again to switch to fresh air/recirculation mode.
- When the "automatic recirculation when parking" function is enabled, to ensure air quality in the vehicle

and prevent the vehicle exhaust from entering the vehicle, the recirculation mode is switched on automatically after you shift into "P".

Defroster for rear windscreen & side mirrors

- Tap this button to heat up and defrost the rear windscreen and side mirrors. The function is automatically deactivated after 15-minute inactivity of the associated button. Tap this button a second time to disable the function.
- This function is not for drying raindrops or melting snow.

WARNING

- Using the side mirror electric heating defrosting function for a long time may cause the mirror to wear out faster. Turn off the defrost button when it is not needed.
- Do not touch the side mirrors when the rear defroster is activated, because their surfaces will be hot.

CAUTION

- To prevent the low-voltage battery from discharging, switch off the rear defroster when the motor is running.

Ventilator

- Tap this button to activate A/C ventilation control. The outlet air is natural air.
- Tap this button again to deactivate A/C ventilation control and enter AUTO mode.

Air distribution

- Tap an icon on the infotainment touchscreen to select the corresponding air distribution mode. Air distribution mode can be combined freely in the infotainment, you can turn on multiple modes (up to three) simultaneously by using the touchscreen.

➔ : Air flows to the face level.

↓ : Air flows to the foot level.

🌬️ : Air flows to the front windscreen and side windows.

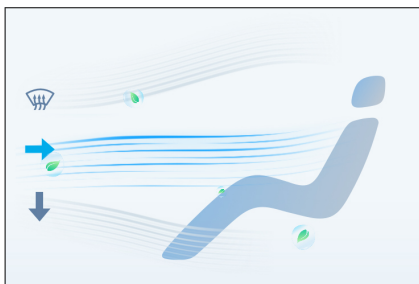

Usage Precautions

- To quickly cool down the interior after long exposure to sunlight, drive for a few minutes with the windows open to exhaust hot air and speed up A/C cooling.
- To speed up cooling, adjust the temperature to "Lo" and use the recirculation mode for a few minutes.
- Make sure that the air intake grille in front of the windscreen is not blocked (for example, by leaves or snow).
- Avoid blowing cool air onto the windscreen in humid weather. The inner and outer temperature difference can cause glass fogging.
- Keep the space under the front seats clear to improve air circulation.
- In cold weather, run the fan at high speed for one minute to remove snow or moisture from the intake passage and reduce fogging.
- Use recirculation mode for a few minutes for quick heating in cold weather, and switch to fresh air mode to prevent fogging after cabin is heated up.
- In dusty or windy driving conditions, close all windows,
- In heating mode, press the compressor control button to light up the button (turning on the compressor), which can reduce airflow moisture.
- In the ventilation mode, the system introduces the natural wind from outside, which is suitable for spring and autumn.

! REMINDER

- A/C odours:
 - It is normal that there may be a damp and moldy smell just after the A/C is turned on. During A/C operation, condensation often remains in the evaporator, and the wet evaporator can easily absorb unfiltered body sweat and smokes inside the vehicle. Condensation not blown dry makes the dark and damp evaporator surface prone to mold, which is very likely to produce odours by long-term fermentation.
- How to prevent A/C odours:
 - Turn off the A/C and ventilate with natural air before parking to keep the air inside the vehicle relatively dry.
 - Check, clean, and replace the air filter regularly.

! REMINDER

- Try to keep the cabin clean and fresh.
- If the odour persists after the prevention measures are used, it is recommended to contact a BYD authorised dealer or service provider for repair.
- In order to reduce A/C odours, if the A/C is already turned on, the A/C blower may keep running for a while after the vehicle is powered off and locked. That is because the condensed water on the surface of the evaporator needs to be dried to prevent mold fermentation. It is normal for the A/C blower to start running automatically when you lock the vehicle. No need to worry about it.

Vents

Use the adjustment knob to adjust the fan speed or air outlet angle. Move the adjustment knob to their limits to close the air outlet.

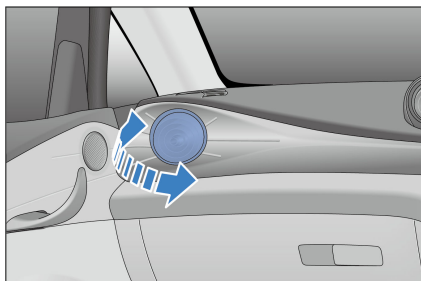

BYD App

BYD App

- BYD app is a mobile application of Internet of Vehicle (IoV) developed by BYD independently. It allows you to control the vehicle remotely and check vehicle conditions, delivering cloud era experience of IoV.
- Search for "BYD" in Google Play or App Store to download and install the BYD app.

Account Registration

App guidance and the following steps give instructions on signing up and logging in after BYD app installation.

1. Open the app, then tap **Sign up** to go to the registration screen.
2. Enter email address registered in BYD authorised dealer, tap **Send email** to receive verification code, and then enter the code in app.
3. Set your password in password setting screen to complete the registration, and then the homepage is displayed.

! CAUTION

- Provide the email address registered at the BYD authorised dealer, or registration will fail.
- In the app, select a country or region on upper right corner of the screen. The default setting depends on your phone setting. If it is not where you make the purchase, choose the right one, otherwise your data will not be accessible.

Vehicle Condition and Control

The BYD app homepage provides information and control items of the vehicle.

1. The homepage shows remaining driving range, SOC, vehicle error information, and status of vehicle driving, charging, A/C system, seat heater, and tyre pressure.
2. Tap lock, unlock, light flashing & honking, or light flashing button to activate the corresponding function.
3. Turn on or off A/C on the app homepage, or tap the A/C card to access other settings, such as temperature regulation. See **P143** for details.
4. At the bottom of the homepage, tap the icon of seats, doors and windows, or tyres to go to the associated screen and check their status.
5. If you have multiple vehicles on an account, tap the vehicle name in the upper left corner of the screen to switch between vehicles.

CAUTION

- The control function of the app is mainly for remote use. To use this function, ensure your phone and vehicle are connected to the Internet.

Individual Centre and Vehicle Management

In BYD App screen, tap **My Account** to go to the individual center.

- Tap the icon on the top right corner of the vehicle card to edit the vehicle name and license plate number.

- **Account and security:** gets back or changes password.
- **Settings:** sets message reception, automatic login, and other items.
- **About Us:** includes privacy policy and information to contact us and give feedback.

Storage

Door Bins

- There is a door bin on each door for storage of beverage bottles or small items.

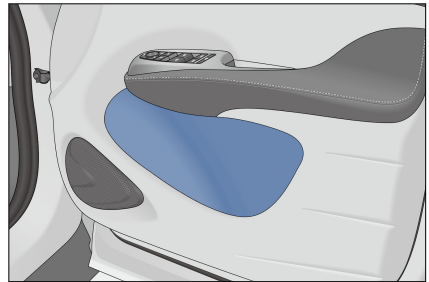

Bill Box

- It is located on the dashboard on the driver's side and used to place invoices, business cards, and similar objects.

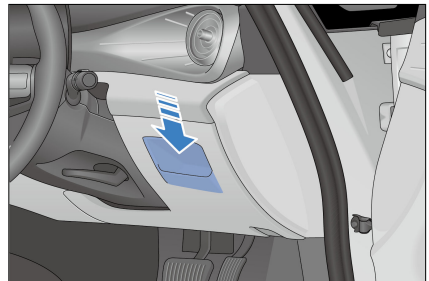

Dashboard Central Storage Compartment

- It is located in the middle of dashboard.

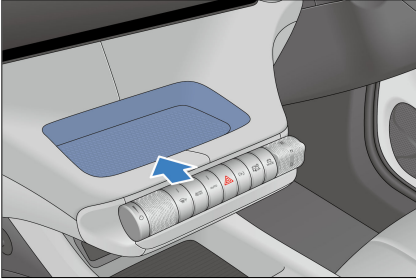

Glove Box

- Pull the handle to open the glove box.
- Push the lid up to close it.

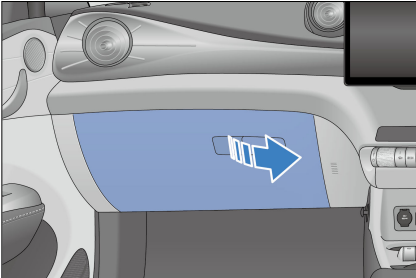

! REMINDER

- To reduce risk of injury in the event of an accident or emergency braking, keep the glove box closed while driving.

Centre Console Storage Compartment

- Located below the dashboard and in front of the centre console. Open its cover to use the space.

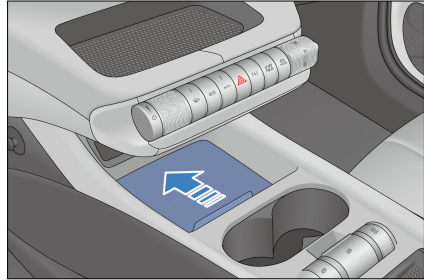

- Below the centre console.

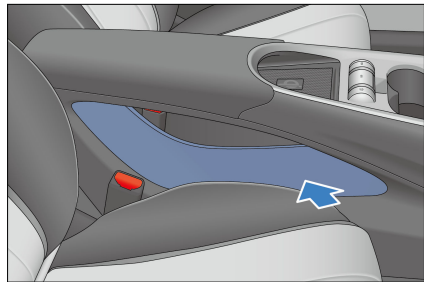

- Behind the centre console.

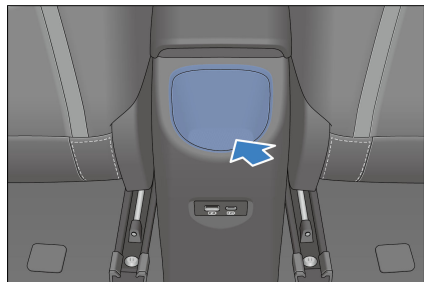

Cup Holder

Front Seat Cup Holder

- The front seat cup holder is located inside the centre console cubby.

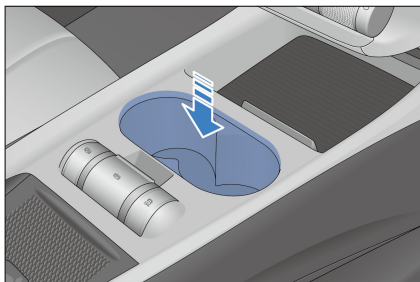

Rear Seat Cup Holder

- Flip the rear seat armrest to use the cup holder.



CAUTION

- Do not start or brake the vehicle suddenly when the cup holders are being used to prevent spillage or scalding.
- Do not place an open cup or untightened beverage bottle in the cup holder, so as to avoid liquid spillage when you are opening and closing the doors and driving.
- To ensure safe driving, the driver is strictly prohibited from taking

CAUTION

the cup out or placing it in the cup holder while driving.

Glasses Case*

- Pull down the glasses case to store glasses.

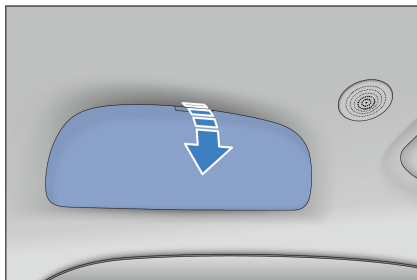

Seatback Pockets

- There are seatback pockets at the back of the front seats for storing magazines, newspapers, or similar objects.

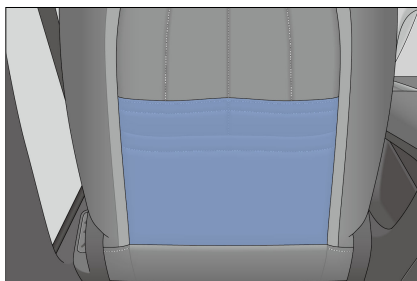

Other Devices

Sun Visor

- ① Sun visor

- To block sunlight from the front, pull the sun visor down.
- To block sunlight from a side, remove the swivel sleeve from the fixed support and turn the visor towards the side window.



② Vanity mirror

- Vanity mirrors are installed on the driver's and front passenger's sun visors.
- To access the vanity mirror, pull the sun visor down and flip open the mirror cover. The vanity mirror indicator lights up. The indicator goes out when you close the mirror cover or fold up the sun visor.

! REMINDER

- Correct use of the sun visor improves driving safety and comfort.

Grab Handles

- Pull the grab handle down for use. The handle returns to its original position when released.

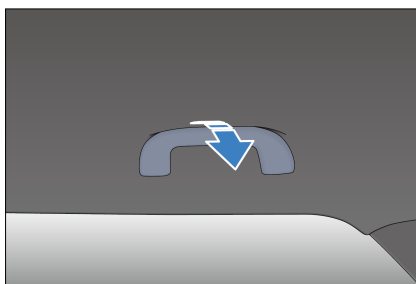

! CAUTION

- Do not hang any heavy objects from the grab handles.

USB Ports

- Front-Row USB Ports:

- ① USB charge port
- ② USB data transmission port

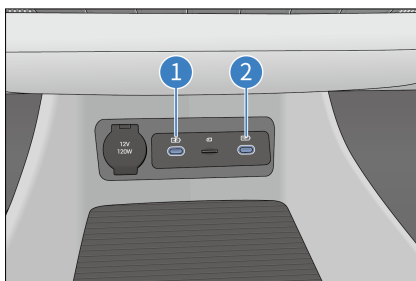

! CAUTION

- It is recommended to use a USB storage device with a partition format of FAT32 and a memory of 8~128G.
- Do not use special USB storage devices to avoid damaging the infotainment system or data in the USB device.

- USB Charge Port

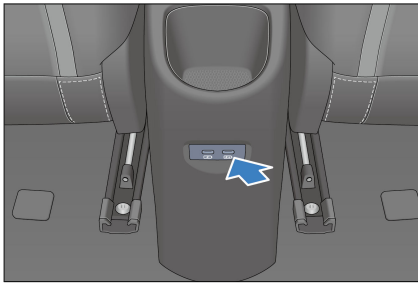

12V Auxiliary Power

- It is used for accessories with 12V DC working voltage and no more than 10A working current.
- The 12V auxiliary power is available only when the ignition has been switched on. Lift the cover to use it.

SD Card Slot*

- Above the centre console storage compartment



- The infotainment system supports TF card (also called Micro-SD card) ranging from 8 to 128GB with a Class 10 speed rating or higher.

CAUTION

- Insert the card horizontally.
- TF cards with a partition format other than FAT32 need to be formatted before using them for the first time, otherwise the system may not recognize them.
- Before removing the TF card, shut down the infotainment system, or video files may be damaged.

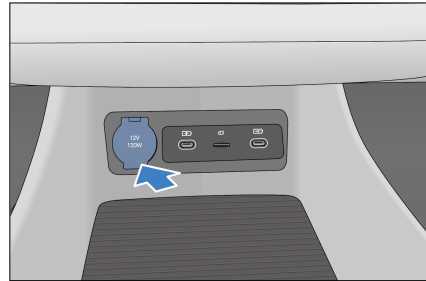

CAUTION

- To prevent fuses from blowing, the power consumption must not exceed 12V/120W of total vehicle load.
- To prevent draining the low-voltage battery, do not use the 12V auxiliary power supply for a long time when the drive motor is not running.
- When the 12V auxiliary power is not in use, close its cover. Do not insert any object other than a suitable plug into the 12V auxiliary power socket or let any liquid ingress the socket, as electrical failure may result.

Wireless Phone Charger*

- The charger charges phones without a cable connection through electromagnetic wave induction.

- On the infotainment touchscreen, slide down the shortcut menu and light up the wireless charger icon .
- After starting the vehicle, place a smartphone screen-up in the wireless charging area to activate the wireless charger.
- To disable the wireless charger: On the infotainment touchscreen, slide down shortcut menu and tap the wireless charging icon. The indicator turns off and the wireless charging function is disabled.

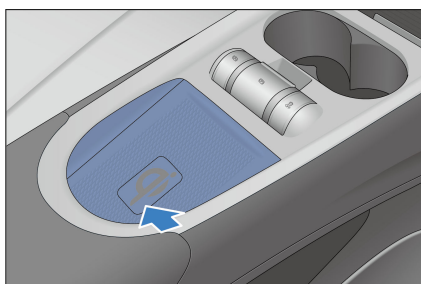

- The wireless charger only works with Qi-certified phones.
- To avoid burning cards with chips, such as bank cards, do not place them between the wireless phone charger area and the phone during charging.

! CAUTION

- Ensure your smart key is more than 10 in (25 cm) away from the wireless charger area when the wireless charger system is working.
- To avoid wireless charger dysfunction or even accidents, do not place coins, metal keys, metal rings, or other articles containing metal in the wireless charger area together with the phone.

! CAUTION

- To avoid damage to the charger area, do not place heavy objects on it. If the phone wireless charger system is faulty and does not work properly, it is recommended to contact a BYD authorised dealer or service provider.
- BYD will not assume any responsibility for any problems caused by improper use. If the product is disassembled or modified, the free warranty will be terminated.
- For safety reasons, do not leave an unattended phone being charged in the vehicle.
- For safety reasons, refrain from checking phone charging status while driving.
- If a metal item is found between the device and the charger rubber pad during charging, do not remove the metal item with bare hands to prevent burning.
- The centre of the phone coil must be aligned with the centre of wireless charger (indicated with text in the charging area), or charging may fail.
- Prevent any fluid from coming into contact with the charger area. The wireless charger will malfunction if water enters the wireless charger via the gap around the rubber mat.
- Charging may stop at high temperatures, and will resume once the temperature drops. BYD makes no commitments for problems caused by external wireless charging coils. Please use with caution.

! REMINDER

- Only one phone can be charged at a time.
- A phone case that is too thick may prevent charging.
- On bumpy roads, the wireless phone charging may intermittently stop and then resume.
- Try to ensure that the surface on which a mobile phone is placed is parallel to the charging module. If the phone moves from the wireless charger area and stops charging, move it back.
- If the phone cannot be charged properly, ensure that there are no foreign objects in the wireless charger area, or wait for the wireless charger area to cool down before trying again. If it is still impossible to charge the phone, contact a BYD authorised dealer or service provider.
- After power-off, if the phone is still charging and the driver's door is opened, the instrument cluster sounds an alarm and the message "Please take your cell phone with you" is displayed for five seconds.

Cargo Cover

- The cargo cover is used for privacy and direct sunlight protection.
- Snap the two grooved sides ① of the cargo cover into the lower C-pillar shield bosses on both sides, and then attach the cover drawstring ②.
- Do the reverse to remove the cover.

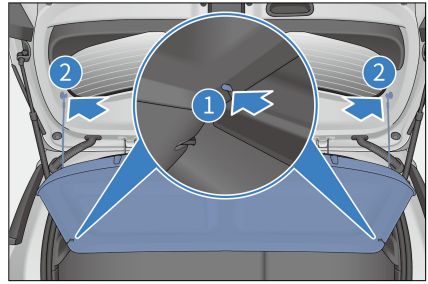

! WARNING

- When installing the cargo cover, make sure that it is installed securely.
- Do not place any objects on the cargo cover.
- Never allow a child to climb onto the cargo cover, otherwise, damage to the cargo cover, or even injury/death to the child, can happen.

Hook

- The hook can be rotated through 180°.
- Only hang items weighing of less than 6.61 lb (3 kg) on the hook.

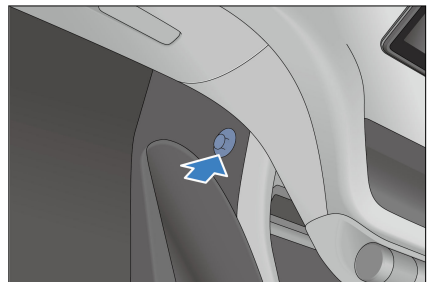

CAUTION

- Do not hang any heavy objects on the hook to avoid damage to the hook.

Window Breaker

A window breaker is installed near the storage compartment under the centre console cubby. As an auxiliary emergency evacuation tool, it is designed to break through a window glass for easier escape in an emergency such as fire or submersion.

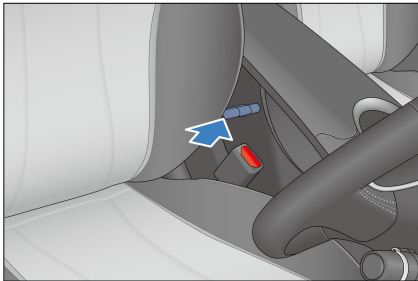

Breaking a Window

1. Decide where to smash.
 - Because there is a special shockproof layer on windscreens, choose a side window, which is easier to shatter.
 - Choose the corner of the window to minimise the smashing time.
2. Smash the glass.
 - Point the breaker to the corner of the window and press its bottom hard. If the glass is not damaged, keep pressing on the same spot until the glass is broken.
3. Remove the broken glass.

- The glass may not fall off completely after being smashed. Knock it by the breaker.
- If the glass is with a film, kick through it.

4. Escape from the vehicle.

- When a gap enough for escape is formed, exit the vehicle immediately and move to safety.

Using the Window Breaker

1. Remove the window breaker cap ①.
2. Align the top end ② of the window breaker with a corner of the side window.
3. Press on the end ③ of the window breaker.

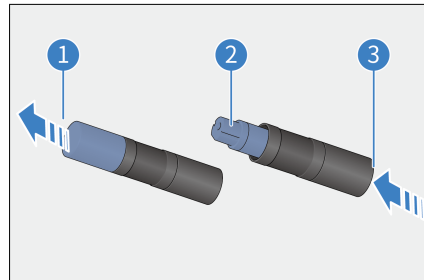

REMINDER

- The window breaker is for emergency use only. Do not remove it frequently in other cases to avoid loss or bracket breaks.
- Be careful to avoid glass cuts while breaking the window.

06

MAINTENANCE

Maintenance Information.....	156
Regular Maintenance.....	158
Self-Maintenance.....	163

Maintenance Information

Maintenance Cycle and Items

Maintenance Plan

- The maintenance plan is designed to ensure stable driving, failure reduction, safe and economical driving.
- The maintenance schedule lists all the maintenance items that are necessary to keep the vehicle in optimum condition at all times.
- The items listed are important and need to be performed according to the specified time interval.
- Hoses with any degradation or damage should be replaced immediately. Rubber hoses (for systems such as A/C, heating, and braking systems) must be checked by professional technicians according to the maintenance schedule.

Maintenance Schedule Requirements

The vehicle must be maintained according to the regular maintenance schedule.

If the vehicle is operated primarily under one or more of the following special conditions, certain maintenance items may need to be performed more frequently.

- Road conditions
 - Muddy, sandy, or snowy roads.
 - Dusty roads
- Driving conditions
 - Use of towed trailer, camping trailer, or roof rack
 - Repeated short distances are driven within 5 miles (8 km), and the outside temperature is below zero.
 - Long idling and/or long distance driving at low speed, for example, using the vehicle as a police car, taxis or using it for transporting goods.

Maintenance Schedule

Vehicle maintenance is performed based on the mileages or months, whichever comes first.

Item	Interval
Brake friction block and disc	Check them every 24 months or 20,000 miles (30,000 km).
Brake piping and hoses	Check them every 24 months or 20,000 miles (30,000 km).
Steering wheel and tie rod	Check them every 24 months or 20,000 miles (30,000 km).
Drive shaft boot	Check it every 24 months or 20,000 miles (30,000 km).

Item	Interval
Ball pin and boot	Check them every 24 months or 20,000 miles (30,000 km).
Front and rear suspensions	Check them every 24 months or 20,000 miles (30,000 km).
Tyre condition and pressure.	Check them every 24 months or 20,000 miles (30,000 km).
Tire wear (check front and rear wheel alignment when tire uneven wear is greater than 2 mm)	Check during maintenance and rotate when necessary; Under severe working conditions, check more frequently and rotate when necessary
EPS corrosion and foreign materials on or ablation of connectors, including wiring harness GND point	Check for them every 24 months or 20,000 miles (30,000 km).
Coolant level in expansion tank	Check it every 24 months or 20,000 miles (30,000 km).
Brake fluid	Check it every 24 months or 20,000 miles (30,000 km).
Bumps or deformation of the highvoltage battery tray, crash bar, shield, and explosion-proof valve, and powertrain leaks	Check for them every 24 months or 20,000 miles (30,000 km).
A/C filter	Check it every 24 months or 20,000 miles (30,000 km). In severe driving conditions, check it every six months and replace it if necessary.
Drive motor coolant	Replace the long-acting organic acid coolant every six years or 60,000 miles (90,000 km).
Brake fluid	Check it during maintenance and replace it every 24 months or 20,000 miles (30,000 km).
Gear oil in the transmission	Replace it at 24 months or 20,000 miles (30,000 km) for the first time, and every 24 months or 30,000 miles (48,000 km) afterwards.
Notes: When checking Item 1, replace chassis parts in a timely manner if any abnormal damage is found.	

! REMINDER

- To keep the high-voltage battery in optimal condition, please fully charge and discharge the vehicle

! REMINDER

regularly, at least every six months or 44,739 miles (72,000 km), whichever comes first, for

REMINDER

battery self-calibration. You can also contact a BYD authorised dealer or service provider for capacity testing and calibration.

Severe driving conditions include:

- Frequent driving in dusty areas or frequent exposure to salt-laden air.
- Frequent driving on bumpy, puddled, or mountain roads.
- Driving in cold weather.
- Frequent and sudden braking.
- Frequent use of a towed trailer.
- Use as a taxi.
- Driving in congested urban areas at temperatures above 90°F (32°C) for more than 50% of total travel time.
- Driving at speeds over 75 mph (120 km/h) at temperature above 86°F (30°C) for more than 50% of total travel time.
- Frequent overloading.

Regular Maintenance

Regular Maintenance

- Pay attention to vehicle performance, sound changes, and visual evidence that indicates service is required. Under any of the following circumstances, the vehicle may need to be adjusted or repaired. Therefore, you are recommended to send the vehicle to a BYD authorised dealer or service provider as soon as possible:
 - Motor start produces unusual noises.

- Coolant remains overheated, is stagnated or leaks.
- Motor jams and produces unexpected noise.
- The motor runs with excessive vibration.
- The motor fails to get started.
- Electric assembly leaks oil.
- Electric assembly emits odours.
- Power declines significantly.
- Water leaks from under the vehicle (A/C condensate is normal).
- Tyre deflates; tyres make excessive noises at turns; tyre wear is uneven.
- Vehicle leads to one side when driving straight on a flat surface.
- Suspension unit movement leads to unusual noises.
- Loss of braking effect; sponge feeling on the brake pedal or clutch pedal; pedal almost contacts the floor; vehicle leads to one side when braking.
- Motor coolant temperature remains high.
- Battery capacity decreased significantly.
- High battery temperature or overheat protection persists, or there is no power output.

REMINDER

- Do not continue driving a vehicle that has not been inspected, as this may result in serious vehicle damage and personal injury.

Vehicle Corrosion Prevention

The most common causes of vehicle corrosion are:

- The underbody of the vehicle is covered in salt, dust or moisture.
- The vehicle or some of its parts are exposed to high humidity and high temperature for a long time.
- The paint layer or underlayer is scratched by minor collision or by stones and gravel.

The following rules should be observed to prevent vehicle corrosion:

- Wash the vehicle frequently.
 - If driving on saline roads in winter or living in coastal areas, wash the landing area of the vehicle at least once a month, and clean the chassis and hubcap with a high-pressure water jet or steam to reduce corrosion. Wash the chassis thoroughly after winter.
- Check vehicle paint and trims.
 - Any chip or crack found on the paint must be repaired immediately to prevent corrosion. If fragments or cracks peel off from the metal surface, it is recommended to go to a BYD authorised dealer or service provider for repair.
- Check interior vehicle.
 - Moisture and dust buildup under the carpet can cause corrosion. Check the undersides of carpets frequently to make sure these areas are dry.
 - Special care should be taken when the vehicle is transporting chemicals, detergents, fertilisers, salt, and other substances. Such substances should be kept in appropriate containers for

transportation. If spillage or leakage is found, clean immediately and keep dry.

- Use fenders.
 - Fenders protect vehicles in saline areas or on gravel roads. The bigger and closer to the ground the fender, the better.
- Park in a well-ventilated and dry area.

Paint Maintenance Tips

- Do not perform secondary painting if there are no obvious scratches on the finish, so as to prevent mismatch or colour incompatibility.
- When the vehicle is not used for a long period, it should be parked in a garage or a well-ventilated place, and special body cover should be used in winter. Choose a shady place for parking temporarily.
- Prevent strong impacts, knocks, or scratches on the paint. If the paint is scratched, dented or if it peels, it should be repaired in time, preferably by professional auto beauty provider.
- Do not touch the paint with a greasy hand or cloth. Do not place greasy tools or rub with organic solvents on the vehicle body so as to avoid chemical reactions.
- The vehicle must be waxed once a month or whenever water resistance performance of the vehicle degrades and be taken to an auto beauty provider for maintenance once every three months.
- High quality polish and wax must be used. If the body finish is severely weathered, use a car cleaning polish in addition to the wax. Carefully follow the manufacturer's instructions and precautions. Chrome finish should be

polished and waxed as well as painted finish.

CAUTION

- When the vehicle is repainted and placed in a high-temperature paint waxing workshop, the vehicle's plastic bumper must be removed to avoid damage caused by high temperatures.

Exterior Cleaning

- The vehicle must be cleaned in time under the following circumstances, which can cause peeling of paint layer or corrosion of the vehicle body and parts:
 - Driving along the coast.
 - Driving on a road with antifreeze.
 - Driving on roads covered with coal tar.
 - Resin, bird droppings, or insect carcasses are stuck on the vehicle.
 - Driving in areas with a large amount of smoke, soot, dust, iron filings, or chemicals.
 - The vehicle is visibly soiled by dust or mud.
 - After raining.

Manual Vehicle Washing

Before washing the vehicle, park it in the shade, and wait for the vehicle to cool down sufficiently.

1. Hose off loose dirt, including all mud or road salts at the bottom of the vehicle and on wheel pits.
2. Wash the vehicle with neutral agents, the mixing of which should be carried out according to the manufacturer's

instructions. Soak a soft cloth with cleaning solution and gently wipe it down along the direction of the water flow. Do not wipe in a circular motion or horizontally.

3. Rinse well—Dried washing agent forms markings. After washing the vehicle in hot weather, rinse all parts properly.
4. Dry the vehicle with a clean soft towel to prevent stay water marks. In order to prevent scratching, do not rub or apply excessive force on the paint.

REMINDER

- Do not use any alkaline washing powder, soapy water, detergents, de-waxing detergents or volatile substance (gasoline, kerosene, or solvent).
- When cleaning the lights, do not wipe their surface with alcohols such as alcohol and windscreen washer fluid, ketones such as lacquer thinner and insect remover, or other chemical solvents such as gasoline, thinner, and carbon tetrachloride. Doing so can cause the light casings to crack.
- It is recommended that vehicles travelling in coastal or heavily polluted areas be washed once a day.
- When washing the vehicle, make sure that the high-pressure water jets are at a sufficient distance from the vehicle, and do not aim them directly at the sealing strips, to prevent high pressure from distorting and even damaging the strips and water from leaking into the vehicle.
- Do not use blades or gasoline to remove hard dirt from the vehicle

 **REMINDER**

body. The plastic wheel trim is easily damaged by organic matter. If any organic matter splashes on the vehicle trim, remove it with water and check whether the trim is damaged. Please replace any seriously damaged plastic wheel trim in a timely manner. Otherwise, the trim may fall from the wheel during vehicle movement and cause an accident.

- Do not use abrasive cleaning agents to scrub the bumper.
- Clean polished metal parts with carbon cleaner and wax them regularly for protection.
- Be careful when cleaning the chassis to avoid cutting hands.

Automatic Vehicle Washing

When choosing an automated vehicle wash service, be aware of certain types of brushes, unfiltered rinsing water, or machine-specific rinsing procedures that may scratch the paint and affect its gloss and durability, especially darker colours. Before washing the vehicle, it is best to consult the staff of the car wash service provider to understand which washing procedures are the safest for the paint finish.

Interior Cleaning

 **REMINDER**

- Prevent direct water splash onto the dashboard or floor when washing the vehicle, as these may cause electrical faults.
- Do not wash the vehicle's floor.

Carpet

- Clean carpets with a good foam detergent.
- Use a vacuum cleaner to remove as much dust as possible. Several types of foam detergents can be used. Some are in spray cans, and the others are powders or liquids, which produce foam when mixed with water. Clean the carpets with foam soaked sponge or a brush, scrubbing in a circular motion.
- Do not use plain water, and keep the carpets as dry as possible.

Seat Belts

- The seat belts can be cleaned with neutral soapy water or lukewarm water.
- Scrub the seat belts with a sponge or soft cloth. Check the seat belts for excessive wear, tear, or cut marks.

 **CAUTION**

- Do not clean the seat belt with colourant or bleach. These substances may decrease the seat belt's strength.
- Do not use any seat belt that is not dry.

Doors and Windows

- Doors and windows can be cleaned with any ordinary detergent.
- Check the door brakes regularly. If a door brake lever is found with visible dust accumulation, wipe it with a wet soft cloth.

 **CAUTION**

- When cleaning the inside of the rear windows, take care not to scratch or damage electric heating wires or junctions.

A/C Control Panel, Car Speakers, Dashboard, Control Panel and Switches

- Clean the A/C control panel, car speakers, dashboard, control panel and switches with a wet soft cloth.
- Wipe dust off gently with a clean soft cloth soaked in lukewarm water.

 **CAUTION**

- Do not use organic substances (for example, solvents, kerosene, alcohol, and gasoline) or acid or alkali solutions. These chemicals can cause discoloration, staining, or flaking.
- Please confirm that the detergent or polishing agent to be used does not contain the above substances.
- If a new liquid washing agent is used, do not splash it onto the interior surface of the vehicle, because it may contain the above substances. If there is any spillage, immediately clean it thoroughly.

Leather

- Leather trimmings can be cleaned with a neutral detergent for woolen.
- Use a soft cloth with a neutral detergent solution to wipe off the dust, and then use a clean, wet cloth to wipe the remaining detergent thoroughly.
- If leather gets wet, wipe it with a clean soft cloth and air dry it in a cool, ventilated place.

- For any questions about vehicle cleaning, please consult a local BYD authorised dealer or service provider.

 **CAUTION**

- If dirt cannot be cleaned off using a neutral detergent, clean it with a detergent that does not contain organic solvents.
- Do not clean leather with any organic material such as volatile oil, alcohol, gasoline, acid or alkali, as these will cause discoloration.
- Do not clean leather with a nylon brush or synthetic fiber cloth, as these may scratch the fine patterns on the leather surface.
- Mold may grow on dirty leather trimmings. Special care must be taken to avoid oil stains and trimmings must always be kept clean.
- Prolonged exposure to sunlight will cause leather to harden or shrink, so the vehicle should be parked in a shady and cool place, especially in the summer.
- In hot weather, avoid placing vinyl or waxy items on the trimmings, as these may stick to leather in high temperatures.
- Improper cleaning of leather trimmings may cause discoloration or spots.

Self-Maintenance

Self-Maintenance

Self-Maintenance Precautions

- If maintenance is to be carried out by the owner, be sure to follow the correct steps specified in this section.
- Note that improper and incomplete maintenance will affect the good use of the vehicle.
- This section only lists instructions on simple maintenance items that can be done by the owner. However, there are many items that must be done by qualified technicians with special tools.
- Special care must be taken in maintaining vehicles to prevent accidental injuries. Make sure to obey the followings:



CAUTION

- Beware of short circuits, as some circuits and vehicle components carry high current or voltage.
- If coolant overflows, wipe it with a dry cloth or tissue to prevent damage to components or vehicle paint.
- If brake fluid overflows, rinse it with water to prevent damage to components or vehicle paint.
- When replacing wiper blades, do not allow the wipers to scratch the glass surface.
- Before closing the bonnet, check whether any tool or wipe cloth is left in the engine compartment.
- When working inside or under the vehicle, always wear goggles to



CAUTION

protect your eyes against flying or falling objects or splashing liquid.

- As brake fluid may damage the skin or eyes, be careful when filling it. If your skin or eyes are exposed to brake fluid, immediately flush with clean water. Seek medical attention immediately if discomfort persists.

Checks

The following items should be checked according to usage or specified mileage:

- Coolant level - Expansion tank coolant level should be checked at each charge.
- Windscreen washer fluid - The residual amount of washer liquid in the tank should be checked monthly. When washer liquid is frequently used, the residual amount of liquid should be checked at each charge.
- Windscreen wiper - Check wiper conditions monthly. If the wiper does not work, check it for wear, cracking, or other damage.
- Brake fluid level - Check the level monthly.
- Brake pedal - Check whether the brake pedal is operating properly.
- EPB switch - Check whether the switch is functional.
- Low-voltage battery - Check battery conditions and check for terminal corrosion monthly.
- A/C system - Check the operation of A/C units weekly.

- Tyres - Check tyre pressure monthly. Check tread wear and whether there are foreign bodies embedded.
- Windscreen defrosters - Check the defroster vent monthly.
- Lights - Check the condition of headlights, position lights, tail lights, high mount brake light, turn signals, rear fog lights, brake lights and license plate light monthly.
- Doors - Check whether the boot lid and all other doors (including rear doors) can be opened freely and locked securely.
- Horn - Check whether the horn is functioning properly.

REMINDER

- Do not continue driving a vehicle that has not been inspected, as this may result in serious vehicle damage and personal injury.

Lights

Headlight adjustment

- Headlights are aligned before vehicle delivery. If the vehicle carries heavy load frequently, headlights may need to be realigned. It is recommended to have the headlights aligned by a BYD authorised dealer or service provider.

Fogging of lights

- Combination lights, tail lights, and turn signals on the side mirrors may become foggy after heavy rain or cleaning. This is similar to condensation on the side window during rain. It does not mean any problem with your vehicle.
- The lights are relatively enclosed and narrow spaces. The temperature is very high when they light up

(the mask and reflector could be burned and deformed easily), so they need heat dissipation. There are heat dissipation holes on the lamp housing for convection. The greater the temperature difference is, the more active the convection is. During the convection, the moisture in the air inevitably enters a lamp. Factors such as exposure to sunlight, convection, and bulb heating can cause the moisture in the air to condense into fog or water beads easily on the lamp surface at low temperatures. This is called fogging of lights.

WARNING

- The headlight bulb becomes very hot when illuminated. Grease, sweat, or scratches on the surface of the bulb glass will cause the bulb to overheat and break.

REMINDER

- If fog presents inside the headlight and inside the turn signals on side mirrors, it may be due to high air humidity or significant temperature difference between the vehicle and its surroundings. In that case, turn on the headlight or turn signal while driving. The fog will evaporate after a short period of driving.
- If there is a noticeable amount of water inside the lights, it is recommended to drive the vehicle to a BYD authorised dealer or service provider for maintenance.

Canopy Maintenance*

- Wipe off dust or sand on the outer sealing strips of the canopy with a damp cloth to avoid scratches,

which may reduce canopy sealing performance.

- Wipe off dust or sand on the molding edges of the front glass with a damp cloth to avoid scratches, which may reduce canopy sealing performance.
- Clean the rails on both sides and the front channels frequently to avoid the accumulation of foreign materials like dust, sand, and leaves, and prevent such debris from blocking drainage holes, which could result in poor drainage of the canopy.
- When washing the vehicle, make sure that the high-pressure water jets are at a sufficient distance from the vehicle, do not aim them directly at the sealing strips, to prevent high pressure from distorting even damaging the strips and water from leaking into the vehicle.

Vehicle Storage

- If the vehicle needs to be parked for a long time (more than a month), the following preparations should be made. Proper preparation helps prevent degradation and ensure easy use of the vehicle. If possible, park the vehicle indoors.
- Charge the vehicle on time.
- Thoroughly clean and dry the body surface.
- Clean the interior of the vehicle to ensure that carpets and mats are completely dry.
- Release the parking brake and set the gearshift lever in parking gear.
- Open one window slightly (if the vehicle is stored indoors).
- Disconnect the negative terminal of the low-voltage battery.

- Pad the front wiper arm with a folded towel or cloth to keep it out of contact with the windscreen.
- To reduce adhesion, apply silicone lubricant to all door seals and body wax to the painted surface where the door seals meet.
- Cover the vehicle body with a breathable covering made of a "porous material", such as cotton. Non-porous materials, such as plastic sheeting, can build up moisture and damage the paint.
- If possible, start the vehicle regularly (preferably once every month). If the vehicle has been parked for a year or more, go to a BYD authorised dealer or service provider for comprehensive maintenance.

Bonnet

Opening the Hood

1. Pull the handle on the right under the dashboard twice. The bonnet unlocks and opens slightly.

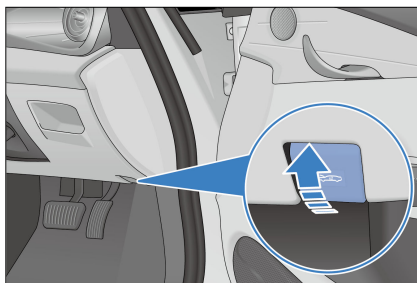

2. To open the bonnet: Lift up the bonnet and support it with the with a stay bar.

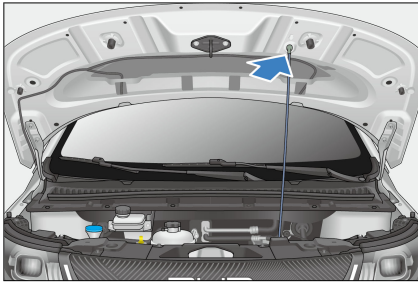

Closing the Bonnet

1. To close the bonnet: Remove the stay bar, lower the bonnet to about 30 centimeters above the front grille and release it, so that the fall locks it.
2. After closing the bonnet, check whether the latch is securely locked.

! REMINDER

- Ensure that the bonnet is closed and locked firmly. Otherwise, the bonnet may suddenly open during driving, resulting in an accident.
- Do not force down the bonnet or release it from a high position.
- If the hood is not closed, do not press it with force, unlock the hood and close it again.

Cooling System

- It is required that the liquid level should be between the Maximum (MAX) and Minimum (MIN) marker lines of the expansion tank.
- The coolant must always be of the same specification as the original, without adding any mixture. Different brands and types of coolant should not be mixed.

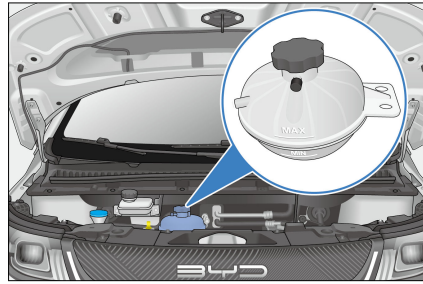

- Refill coolant to the MAX line if the level is below the MIN line. Check the cooling system for leakage.

! CAUTION

- Do not add any rust inhibitor or other additives to the cooling system for they may be incompatible with the coolant or the motor components.
- Before opening the reservoir cap, make sure that the motor, high-voltage electronic control assembly, refrigerant reservoir and radiator are all cooled down.
- It is recommended to go to a BYD authorised dealer or service provider for adding the special type of coolant.

! REMINDER

- Opening the coolant expansion tank when the motor has not yet fully cooled down may cause coolant to squirt out, resulting in severe burns.
- Coolant may fade in colour when exposed to high ultraviolet rays such as sunlight. If the bonnet needs to be opened in the process of vehicle use and maintenance, direct sunlight should be avoided. The performance parameters of

! REMINDER

coolant do not change after it fades, and normal use is not affected.

Braking System

- Check the level in the fluid tank monthly, and change the brake fluid according to the travel time and mileage specified in Maintenance Schedule.
- Be sure to use the brake fluid of the same specifications as the original brake fluid, and different types of brake fluid must not be mixed.
- It is required that the level in the fluid tank should be between "MAX" (maximum level) and "MIN" (minimum level) marks.
- If the level is below the MIN mark, check if the braking system leaks and the brake friction blocks are worn.

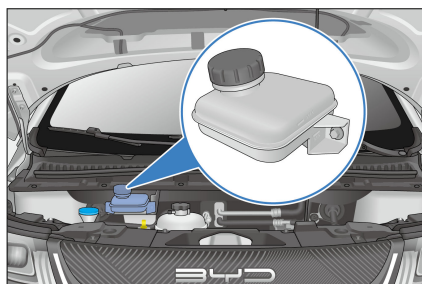

Washer

- During normal use, check the liquid level of the windscreen washer reservoir at least monthly.
- If the windscreen washer is used frequently, the level of the washer reservoir should be checked more frequently.

- High quality windscreen washer fluid should be added to improve stain removal and prevent freezing in cold weather.

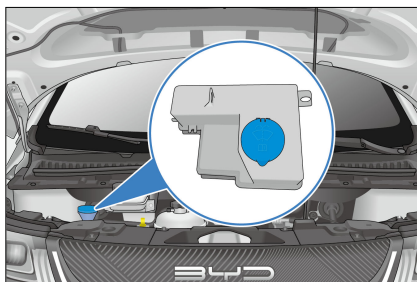

- When refilling the washer fluid, use a clean cloth dipped in the windscreen washer fluid to clean the windscreen wiper blade. This helps keep the wiper blade in good condition.

! CAUTION

- Do not inject vinegar-water solution or acid solution into the windscreen washer fluid reservoir.
- It is recommended to use certified windscreen washing fluid having a pH value from 6.5 to 10.

A/C System

- The A/C system is a closed system, and any important maintenance work should be performed by professionals from a BYD authorised dealer or service provider.
- The following practices help ensure that the A/C system works effectively.
 - Check the radiator and A/C condenser regularly.
 - Remove leaves, insects, and dust from the front surface of the A/C system. These deposits hinder the air flow and reduce the cooling effect.

- In cold months, turn the A/C on once a week for at least 10 minutes to circulate the lubricating oil in the refrigerant unit.
- If A/C cooling efficiency decreases, go to a BYD authorised dealer or service provider for maintenance.

CAUTION

- Whenever the A/C system is maintained, the maintenance station should use a refrigerant recycling system. The system can recycle refrigerant to avoid environmental pollution caused by directly discharging refrigerant.

Wiper Blades

The blade strip, made of synthetic rubber, is a vulnerable part. Various service environment of the vehicle and usage habits of drivers can damage the blades. Therefore, please observe the following to ensure the service life of blades and driving safety:

- Do not use a blade to remove ice from the windscreen surface. Use a customised ice scraper.
- Do not scrape the windscreen surface if it is dirty, greasy or waxy.
- Keep the windscreen surface clean. Do not scrape dust, sand, insects, or foreign bodies on the windscreen surface.
- During vehicle washing and body paint maintenance, there is no need to wax the windscreen, as the wax layer reflects light in bad light, affecting the line of sight and driving safety. After washing the vehicle, rinse the blade with plain water, and use special windscreen wax cleaner to remove the wax layer on the windscreen.

- To prevent excessive water pressure from damaging the blades, do not wash the blades directly with a water jet.

Maintenance Rules

- Clean windscreen and blade regularly (preferably once a week or once every two weeks).
- Wipe the wiper regularly (preferably once a day or once every two days). When using a blade to wipe the windscreen, keep the windscreen fully wet. (When there is no rain, the washer liquid must be sprayed in advance).
- Clean the windscreen with a special windscreen washer fluid.
- Promptly clean mud and insect carcasses stuck to the windscreen with a rag.
- When there are marks on the windscreen caused by gravel, maintenance must be carried out timely. (It is recommended that windscreen repair resin products should be used and the windscreen should be replaced if marks are too large or too many.)
- Replace the wiper blades regularly, preferably once every six months.
- When cleaning the windscreen, raise the wiper arm in advance. The specific operation method is as follows:
 1. Go to infotainment touchscreen →  → **Vehicle health** → **Overhaul** to enable front wiper maintenance. The wiper is then rotated down.
 2. Grasp the upper end of the wiper arm and carefully lift the wiper arm and blade assembly.

Tyres

- For safe driving, tyres must be made and sized to fit the vehicle, with good tread and standard tyre pressure.

WARNING

- Using tyres with excessive wear or insufficient/excessive pressure can result in accidents, severe injury, or death.
- Please follow all instructions in this manual regarding tyre inflation and maintenance.

Tyre Inflation

- Keep tyres properly inflated to provide the best combination of maneuverability, tread life, and driving comfort.
- Under-inflated tyres can cause uneven tyre wear, affect maneuverability and energy consumption, and are prone to leakage due to overheating.
- Over-inflated tyres reduce riding comfort and are prone to damage from uneven roads. In severe cases, the risk of tyre bursting poses severe threats to the safety of the entire vehicle. Over-inflation will also cause uneven wear and tear of tyres, affecting tyre service life.
- When tyres are cold, you can decide whether to replenish tyre pressure according to the tyre pressure values displayed on the instrument cluster.
- Tyre pressure should be measured while tyres are at ambient temperatures. This means that it should be measured at least three hours after stopping the vehicle. If you must drive the vehicle before the tyre pressure is measured, tyres can still be considered at ambient temperatures

as long as the travelled distance is not more than 0.9 mile (1.6 km).

- It is normal that tyre pressure reading measured while tyres are hot (after travel of several miles) is 0.3–0.4 bar (30–40 kPa) higher than when tyres are cold. In that case, do not deflate tyres in order to achieve the specified cold tyre pressure reading; otherwise, the tyre pressure will be insufficient.

REMINDER

- The recommended cold tyre pressure is indicated on the label affixed to the driver's door frame.
- Tubeless tyres have a self-sealing function when they are punctured. However, because in fact usually there is a very slow air leak, as soon as the tyre begins to depressurise, carefully look for the leak location.

Checks

- Whenever checking tyre inflation, check tyres for damage, foreign body piercing, and wear.
- Replace the tyre if bumps, or tread or side damage are found. Tyres must be replaced if any of the cases happens.
- Replace the tyre if there are cracks on its side, or if its fabric or cord can be seen.
- Replace tyres with excessive tread wear.
- Tyre treads are cast with wear bars. When the tread is even with the wear bar, its thickness is less than 0.06 in (1.6 mm). The adhesion of tyres worn to this extent is very small on wet roads.



- Tyres with exposed wear bars are experiencing serious performance loss and therefore must be replaced.

Maintenance

- In addition to proper inflation, proper wheel alignment also helps reduce tread wear.
- If uneven tyre wear is found, go to a BYD authorised dealer or service provider and check the wheel alignment.
- Although the vehicle has been balanced in the factory, it needs to be re-balanced after running for a period of time.
- If there is some kind of continuous vibration at high vehicle speeds (above 50 mph, or 80 km/h), but not at low vehicle speeds, go to a BYD authorised dealer or service provider for tyre checks.
- If a tyre has been repaired, be sure to re-balance it.
- After installing a new tyre or replacing a new wheel, always perform tyre balancing.

CAUTION

- Improper wheel balancers can become loose and fall off, which damages the vehicle

CAUTION

or surrounding objects during vehicle travel.

- Improper wheel balancers damage the aluminium rims of the vehicle. Therefore, it is recommended to use original wheel balancers.

Tyre Rotation

- In order to make tires wear the same and prolong their service life, it is recommended to regularly (no more than 10,000 km) check the wear of the tire inner and outer tread and rotate the tires and conduct four-wheel alignment, inspection and adjustment if necessary.
- Do not rotate tyres when a spare tyre is used for the vehicle.
- After tyre replacement, go to a BYD authorised dealer or service provider for tyre pressure matching.

Directional tyres and wheels

- When purchasing replacement tyres, you may find that some tyres are "directional," which can only be rotated in one direction. If directional tyres are used, only the front and rear wheels can be swapped in tyre rotation.
- As shown:
 - ① Non-directional tyres and wheels.
 - ② Directional tyres and wheels.

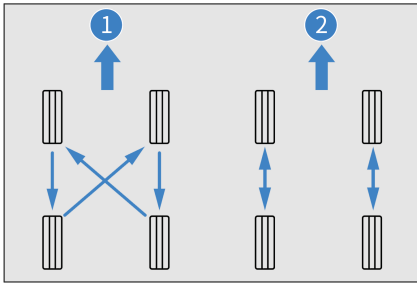

Replacing Tyres and Wheels

- Original tyres maximise performance, while providing the best combination of maneuverability, driving comfort and service life.
- It is recommended to go to a BYD authorised dealer or service provider for replacement of original tyres.
- Replacement of tyres with different sizes, road ranges, rated speeds and maximum cold pressures (marked on the tyre side) or mixed use of radial tyres and diagonal tyres can reduce braking ability, driving force (ground adhesion) and steering accuracy.
- Unsuitable tyres affect the maneuverability and stability of the vehicle, and may lead to accidents.
- Do not replace only one tyre, otherwise it will seriously affect the maneuverability of the vehicle.
- ABS works by comparing wheel speed. When replacing a tyre, use a tyre of the same size as the original tyre. The size and structure of the tyre affect wheel speed and may lead to uncoordinated system operation.
- If the wheel needs to be replaced, ensure that the specifications of the new wheel match those of the original wheel. New wheels are available for purchase at BYD authorised dealer or service provider. Please consult a BYD

authorised dealer or service provider before replacing the wheels.

! WARNING

- Please observe the following precautions to ensure proper vehicle maneuverability and control.
- Do not mix radial tyres, bias belted tyres, or diagonal ply tyres on the vehicle.
- Do not use tyres with dimensions other than those recommended by the manufacturer.

Fuses

All vehicle circuits are provided with fuses to prevent short circuit or overloading. These fuses are mounted in the under-bonnet power distribution box (PDB) and dashboard PDBs, respectively, which include fuse labels??? showing the correspondence of fuses with electrical components.

- The fuses under the bonnet are located at the left rear part in the engine compartment. To open it, remove the trim first, and press the latch.

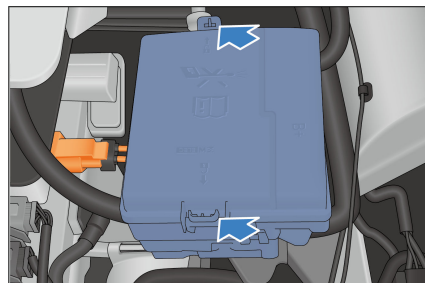

- The dashboard fuse under the driver's side is located on the right side of the dashboard. Take apart the lower body of the dashboard to check the fuse.

- Replacement of blown fuses with ones of higher amperage can significantly increase the likelihood of damage to the electrical system.
- If there is no spare fuse of the same amperage, use a fuse with lower amperage instead.

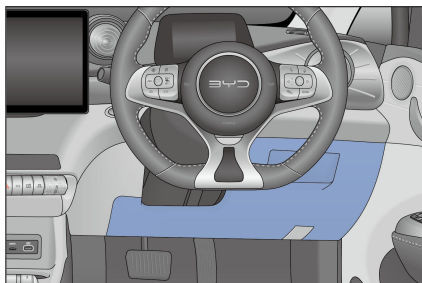

! REMINDER

- Do not use fuses with amperage higher than the rated ampere value or any other solution to replace the fuses, as this can cause serious damage or even a fire.
- If a fuse blows, it is recommended to check or replace the fuse at a BYD authorised dealer or service provider.

07

WHEN FAULTS OCCUR

When Faults Occur.....174

When Faults Occur

Reflective Vest

The reflective vest is in the tool kit. In case of emergency, always wear the reflective vest properly before you check for faults or handle accidents to ensure your safety.

If Smart Key Battery Is Exhausted

If the smart key indicator does not flash and the vehicle cannot be started using the start function, the smart key battery may be exhausted. It is recommended to contact a BYD authorised dealer or service provider for battery change as soon as possible. In this case, you may start the vehicle in no power mode.

CAUTION

- Do not expose the smart key to high temperatures.
- Do not hit or slam the key with hard objects.
- Check for nearby radio stations, transformer substations or airport radio transmitters that interfere with the normal operation of electronic smart keys.
- After locking the vehicle and arming its anti-theft alarm system, keep the key away from the vehicle if you do not use the vehicle; otherwise the automatic card finding of the vehicle will consume the low-voltage battery and the smart key.

1. Use the mechanical key to unlock the vehicle.

2. Put the smart key on the no-power sign on the auxiliary dashboard.
3. Press the START/STOP button while pressing the brake pedal to start the vehicle normally.

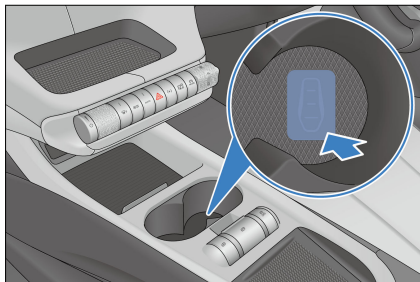

Emergency Shutdown System

- The emergency shutdown system is activated and the high-voltage system is automatically shut down when the following conditions are met:
 - The airbags do not deploy after a frontal collision.
 - There is a rear collision.
 - The vehicle system is faulty.
- The OK indicator goes off if any of the above situations occurs.
- Activating the emergency shutdown system in the noted types of collision minimises the risk of injuries or accidents.
- The vehicle system cannot be switched into the OK status once the emergency shutdown system is activated. In that case, it is recommended to contact a BYD authorised dealer or service provider for help. Even if the ignition switch is set to the OK position, the system will be turned off immediately. Contact a BYD authorised dealer or service provider as soon as possible.

Vehicle Fire Rescue

In case of fire, continue to operate the vehicle as follows according to the actual situation:

1. Switch the ignition off, and leave the vehicle.
2. On the precondition that personal safety is ensured, if the fire is small and slow, use a dry powder fire extinguisher to put out the fire, and call for help immediately.
3. If the fire is large and growing quickly, stay away from the vehicle and call the fire brigade, informing them that the vehicle is equipped with a high-voltage battery pack, and wait for rescue.



CAUTION

- Wear insulated gloves during vehicle disassembly. Use fire extinguishers of designated type. Water or incorrect fire extinguishers may cause electric shock.
- In the event of other special conditions that cause flying projectiles (such as interior trims and glass), stay away from the vehicle and promptly ask a BYD authorised dealer or service provider to come to the site for handling.

Battery Leakage Rescue

After a collision, if there is battery leakage, an acrid smell inside the vehicle, visible acid flow outside the vehicle, or any smoke with the battery pack:

1. Switch the ignition off, and disconnect the low-voltage battery if conditions permit.

2. Call a BYD authorised dealer or service provider and the fire brigade, informing them that the vehicle is equipped with a high-voltage battery pack, and wait for rescue.

If a Collision Occurs

In case of collision, operate the vehicle as follows according to the actual situation:

1. Switch the ignition off, and disconnect the low-voltage battery if conditions permit.
2. Call immediately a BYD authorised dealer or service provider for rescue.
3. Carry out a simple inspection, if conditions permit: Check whether any edge of the high-voltage battery tray is cracked and whether any obvious liquid flows out.

- Damage to high-voltage components is not identifiable in all cases. Do not handle damaged components or touch them with jewellery or other metal objects.
- If skin comes in contact with leaked fluid, wash it immediately with plenty of water for 10-15 minutes. If there is still any discomfort, apply 2.5% calcium gluconate ointment, or soak in 2% to 2.5% calcium gluconate solution. If the condition does not get better or discomfort persists, seek medical help immediately.

- Do not touch the orange high-voltage cables or other high-voltage components. Only authorised repair personnel is allowed to work on high-voltage systems.
- Do not damage, modify, disassemble, or disconnect the orange high-voltage cables from the high-voltage grid.

- Inform the firemen and rescue personnel that the vehicle is equipped with a high-voltage battery pack.

! WARNING

- Do not touch any spilled liquid, and stay away from a leaking vehicle or high-voltage battery.
- Do not dispose of the leaked fluid into the water or soil or other environment.
- The vehicle system operates with high-voltage DC power. It generates a lot of heat before and after vehicle start-up and when the vehicle is powered off. Watch out for high pressures and high temperatures.
- Do not disassemble, move, or alter high-voltage battery components and connecting cables as their connectors can cause serious burns or electric shock and may result in personal injury or death. The orange cables are part of high-voltage wiring harness. Users must not repair the vehicle's high-voltage system by themselves. If any repair is required, it is recommended to go to a BYD authorised dealer or service provider.
- The remote control key and high-voltage components of the vehicle may affect and harm people carrying medical devices.

If the Vehicle Needs Towing

If the vehicle needs towing, it is recommended to contact a BYD authorised dealer or service provider, a professional towing service, or the

organisation you joined for roadside assistance.

! WARNING

- The vehicle must not be towed by other vehicles using only ropes or chains.

Common towing methods include:

- Flatbed device
 - If the vehicle fails and needs towing, a flatbed is recommended. When moving a vehicle on a flat trailer, keep all wheels off the ground. Towing the vehicle on front or rear wheels alone may damage high-voltage components.

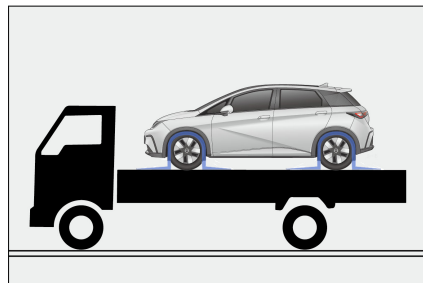

! CAUTION

- When moving a vehicle on a flat trailer, make sure that the vehicle being moved is properly secured to prevent it from sliding back.
- It is recommended to use professional tie-down straps and tensioners, and employ the over-the-wheel method to secure the vehicle.
- When fixing the vehicle, do not pass the fixtures such as straps and ropes through the wheels or tie them on the chassis,



CAUTION

suspension and other body parts to prevent damaging the vehicle.

- When using a flatbed device, make sure the vehicle is securely fastened to prevent it from sliding.

Tow Eye

The installation point of vehicle tow eye is shown in the illustration.

1. Press to open the tow eye cover.
2. Install the tow eye in the tow eye opening.



- If the vehicle needs rescue, it is recommended to call a professional rescue or the customer service number.
- In emergency rescue situations where the vehicle needs to be towed, observe the following to avoid vehicle damage or personal injuries:
 - The towing vehicle must be in good conditions and the towed vehicle in Neutral; the tow speed must be no more than 5km/h.
 - Never use jerking actions to pull the vehicle.
 - The towed vehicle must not carry any person except for the driver.

- Both towing and towed vehicles must have their hazard warning lights on.
- Only the in-vehicle tow eye can be used, to avoid damages to the vehicle.
- The distance between the towing and towed vehicles must be more than 4 meters but less than 10 meters.
- The width and weight of the towed vehicle must not be greater than those of the towing vehicle.
- When the vehicle is being towed, ensure its surroundings are unobstructed and have enough space and no person is close to the towing device.
- When freeing the vehicle, control to make it travel in the direction of tow force. Dragging the vehicle from the side or vertically is prohibited.
- The towed vehicle must be controlled by a driver inside the cabin, with the steering and braking systems in normal conditions.



WARNING

- Rescuing a stuck or high-centered vehicle by using the tow eye is prohibited. Instead, calling a professional rescue or the customer service number is recommended.
- If the steering or braking system of the towed vehicle fails, contact a professional rescue or the customer service number. Do not tow the vehicle in such cases.

If a Tyre Goes Flat

1. In case of a flat tyre, slow down, keep straight and drive off the busy road to a safe place.

2. Park on solid, flat ground and avoid motorway forks.
3. Engage the EPB and press the "P" button.
4. Power off the vehicle and turn on the hazard warning light.

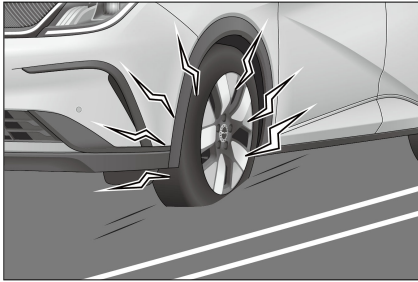

5. Be sure to have all passengers get off the vehicle and ask them to go to a safe place away from crowded traffic.
6. To prevent slipping, secure the vehicle by wedging the tyre diagonally against the flat tyre.

⚠ CAUTION

- Do not continue driving with a flat tyre. Driving even a short distance can cause too severe damage for the tyre to be repaired.

In-Vehicle Tools

These include: warning triangle, reflective vest, lug nut cap removal clamp, tyre repair kit, tow eye and adapter for the anti-theft wheel bolt. The reflective vest is in the glove box on the passenger's side, while others are stored in a tool box under the boot cover flap.

- ① Warning triangle
- ② Lug nut cover removal clamp
- ③ Tyre repair kit
- ④ Tow eye

- ⑤ Reflective vest
- ⑥ Adapter for the anti-theft wheel bolt

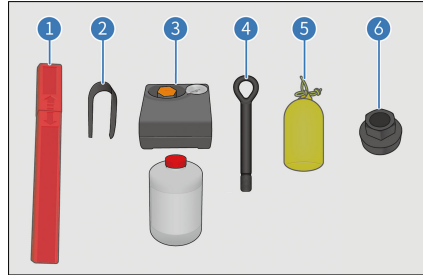

Placing the warning triangle

! REMINDER

- When parking for repair, remember to place the red triangle side facing oncoming vehicles, 328 ft - 656 ft (100-200 m) away from the vehicle. After the repair, recover the warning triangle for future use.

The warning triangle is used to warn vehicles coming from behind and to avoid collisions due to high speed or late braking.

How to use the warning triangle:

1. Take the warning triangle out of its box.
2. Attach the ends to form a triangle.
3. Release its supports to create a pattern as shown.



Using tyre repair kit

- The tyre repair kit is used to seal small cuts, especially cuts in tread pattern. It is just an emergency solution for you to drive to the nearest service centre, and only for short emergency stretches, even if the tyre is not deflated.

WARNING

- At most, the tyre repair kit can repair holes that are on the tyre tread and are within 0.24 in (6 mm) in diameter. Do not use the kit on holes with larger diameters or in other tyre positions, but call for roadside assistance instead.
- Tyre sealant is highly flammable and harmful to health. Take necessary precautions to prevent fire and smoking, and avoid contact with skin, eyes, and clothing; keep away from children; and do not inhale its vapour.

In case of contact with tyre sealant:

- If tyre sealant comes into contact with the skin or gets into the eyes, thoroughly flush the affected body part immediately with plenty of clean water.
- Change contaminated clothing immediately.
- In case of an allergic reaction, seek medical attention immediately.
- If tyre sealant is ingested by accident, rinse mouth thoroughly and drink plenty of water immediately. Do not induce vomiting, but seek medical attention immediately.

Using the tyre repair kit

- Refer to labels on the inflator and tyre sealant for usage of the kit.
- If the inflator needs to be connected to a power source, plug the inflator into the vehicle's 12V socket, start the vehicle, and switch on the inflator. The tyre sealant is then filled through the inflator hose into the tyre along with air.

REMINDER

- Make sure the inflator switch is off when plugging the power supply into the 12V socket in the vehicle.
- The inflator can only be turned on for up to 10 minutes.
- Observe the tyre pressure reading on the inflator.
 - If the tyre pressure does not reach 180 kPa (1.8 bar) within 10 minutes (red area shown in the figure), turn off the inflator. You are recommended to contact a BYD authorised dealer or service provider.

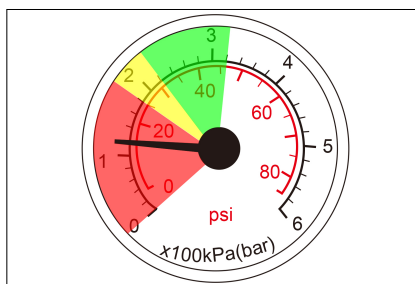

- If the tyre pressure reaches between 1.8 and 3.2 bar (180 and 320 kPa) (green and yellow areas shown in the figure), remove the kit as soon as possible and drive at a speed below 50 mph (80 km/h) within one minute, with the furthest driving distance not exceeding 6 miles (10 km), so that the tyre sealant is evenly distributed within the tyre.

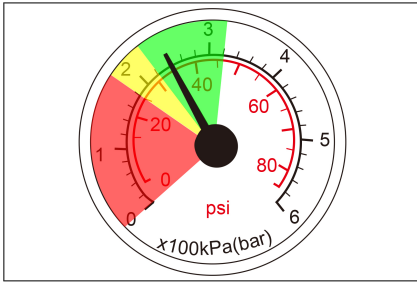

- Stop to check the repaired tyre and the tyre pressure gauge reading on the inflator.
 - If the tyre pressure is greater than 220 kPa (2.2 bar), drive to the nearest service centre at a speed below 49 mph (80 km/h).
 - If the tyre pressure is between 130 and 220 kPa (1.3~2.2 bar), repeat the process to fill the tyre sealant into the tyre and observe the tyre pressure gauge reading on the inflator.
 - If the tyre pressure does not reach 1.3 bar (130 kPa), it is recommended to contact a BYD authorised dealer or service provider.

! REMINDER

- Using tyre repair kit on damaged tyres is only an emergency solution. Please change the tyres at a professional repair centre as soon as possible. It is recommended that you contact a BYD authorised dealer or service provider and inform the maintenance technician that the tyre sealant has been used.
- Avoid hard acceleration and high-speed turns.
- Do not exceed the 50 mph (80 km/h) maximum speed limit and replace flat tyres as soon as possible. Do not drive further if

! REMINDER

the vehicle experiences strong vibration, unstable performance, or noise.

- When the tyre sealant is about to expire (see the label on the canister for exact date), replace it with a new one.
- After using the tyre repair kit, it is recommended to purchase new tyre sealant at a BYD authorised dealer or service provider.

Removing the Anti-theft Wheel Nut

Each wheel is fitted with an anti-theft wheel nut, and you need a special adapter in the tool box to remove it.

How to remove:

1. Take out the lug nut cover removal clamp, and remove the cap.
2. Take out the adapter^①, and slide it all the way onto the anti-theft wheel nut^②. After loosening the adapter, the anti-theft wheel nut can be removed.

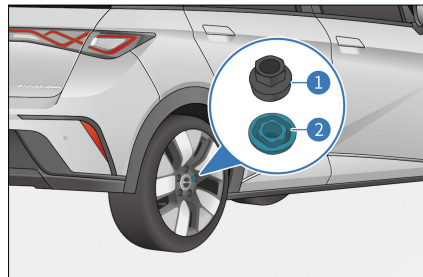

08

SPECIFICATIONS

Vehicle Data.....	182
Information.....	187
Declarations of Conformity.....	190

Vehicle Data

Vehicle Data

Dimensions

Item	Parameter
Length	169 in
	4290 mm
Width (excluding side mirrors)	70 in
	1770 mm
Height	62 in
	1570 mm
Wheelbase	106 in
	2700 mm
Front track	60 in
	1530 mm
Rear track	60 in
	1530 mm
Front overhang	33 in
	830 mm
Rear overhang	30 in
	760 mm
Approach angle	16°
Departure angle	23°

Vehicle mass

Item	Parameter		
Model	Configuration 1	Configuration 2	Configuration 2
Kerb weight	3655 lb	3457 lb	3320 lb
	1658 kg	1568 kg	1506 kg

Item	Parameter		
Model	Configuration 1	Configuration 2	Configuration 2
Front axle load	1971 lb	1936 lb	1885 lb
	894 kg	879 kg	855 kg
Rear axle load	1684 lb	1519 lb	1435 lb
	764 kg	689 kg	651 kg
Maximum allowable total mass	4559 lb	4361 lb	4224 lb
	2068 kg	1978 kg	1916 kg
Front axle load at max. allowable total mass	2251 lb	2189 lb	2154 lb
	1021 kg	993 kg	977 kg
Rear axle load at max. allowable total mass	2308 lb	2169 lb	2070 lb
	1047 kg	984 kg	939 kg
Number of occupants	5 persons		

Drive motor

Item	Parameter		
Model	Configuration 1	Configuration 2	Configuration 2
Model	TZ200XSQ	TZ200XSW	TZ180XSF
Type	Permanent magnet synchronous motor		
Drive type	Front-wheel drive		
Rated power/speed/torque	65/4433/103 (kW/rpm/ft.lbf)		35/4775/52 (kW/rpm/ft.lbf)
	65/4433/140 (kW/rpm/Nm)		35/4775/70 (kW/rpm/Nm)
Peak power/speed/torque	150/16000/229 (kW/rpm/ft.lbf)	130/16000/192 (kW/rpm/ft.lbf)	70/15000/133 (kW/rpm/ft.lbf)
	150/16000/310 (kW/rpm/Nm)	130/16000/260 (kW/rpm/Nm)	70/15000/180 (kW/rpm/Nm)

Economy and power performance

Item	Parameter		
	Model	Configuration 1	Configuration 2
Power consumption per 100 km under comprehensive working conditions	15.9 kW.h/100 km (WLTC)	15.8 kW.h/100 km (WLTC)	15.2 kW.h/100 km (WLTC)
Max. design speed	99 mph		93 mph
	160 km/h		150 km/h
Max. gradeability		30%	

Wheels and tyres

Item	Parameter	
	Configuration 1	Configuration 2
Tyre specifications	205/50R17	195/60R16
Tyre pressure	2.5 bar	
	250 kPa	
Wheel dynamic balance requirement	≤ 0.022 lb	
	≤ 10 g	

Wheel alignment values (at kerb weight)

Item	Parameter	
	Configuration 1	Configuration 2
Front camber (°)	-0.82 ± 0.75	
Front toe-in (°)	0.06 ± 0.08 (side)	
Kingpin inclination angle (°)	11.3 ± 0.75	
Kingpin caster angle (°)	3.16 ± 0.75	
Rear camber (°)	-1.07 ± 0.5 (four-bar linkage)	-1.38 ± 0.5 (twist beam)
Rear toe-in (°)	0.07 ± 0.012 (side)	0.05 ± 0.12 (side)

Braking system

Item	Parameter	
	Model	Configuration 1
Free stroke of brake pedal	0.039~0.197 in	
	1~5 mm	
Front brake disc thickness	0.906~0.984 in	
	23~25 mm	
Rear brake disc standard thickness	0.472 in (four-bar linkage)	0.394 in (twist beam)
	12 mm (four-bar linkage)	10 mm (twist beam)
Rear brake disc minimum thickness	0.394 in (four-bar linkage)	0.315 in (twist beam)
	10 mm (four-bar linkage)	8 mm (twist beam)
Front friction plate standard thickness	0.315 in	
	8 mm	
Front friction plate minimum thickness	0.098 in	
	2.5 mm	
Rear friction plate standard thickness	0.256 in	
	6.5 mm	
Rear friction plate minimum thickness	0.079 in	
	2 mm	

High-voltage battery

Item	Parameter	
	Model	Configuration 1
Type	Lithium iron phosphate battery	
Rated capacity	150 Ah	135 Ah

Recommended oil type and amount

Item	Parameter	
	Model	Configuration 1
Transmission oil	Castrol BOT384	
Transmission oil amount	0.132±0.011 ukgal	0.099±0.011 ukgal

Item	Parameter	
Model	Configuration 1	Configuration 2
	600±50 mL	450±50 mL
Brake Fluid	HZY6	
Brake fluid amount	0.242±0.022 ukgal	
	1100±100 mL	
Motor coolant type	Glycol organic acid coolant: Antifreeze freezing point: -40°F (-40°C)	
Motor coolant amount	0.726±0.044 ukgal	0.682±0.044 ukgal
	3.3±0.2 L	3.1±0.2 L



CAUTION

- The recommended oil types have been tested and approved by BYD. Using other oil types may affect vehicle performance, and could result in malfunctions or component damage.

Seats

Item	Parameter	
Front seats	Forward and backward moving spaces (cushion depth measured)	2.76 in (70 mm) forward from the farthest slide rail stroke
	Seatback angle (cushion depth measured)	25°
	Normal service conditions	Design position: 24° forward and 50° backward; slide rail: 7.48 in (190 mm) forward and 2.76 in (70 mm) backward; slide rail inclination: 4.5°
Rear Seats	Forward and backward moving spaces (cushion depth measured)	No slide rail

Item	Parameter
Seatback angle (cushion depth measured)	27°
Normal service conditions	27°, fixed and non-adjustable

Information

Vehicle Identification

Vehicle Identification Number (VIN)

VIN attaching positions:

- ① Attached on the gearbox
- ② Attached on the VIN slot on the upper cover of the front windscreen cross sill
- ③ Attached on the sheet metal surface inside the bonnet
- ④ Attached on the sheet metal surface on the upper edge of the front bumper beam

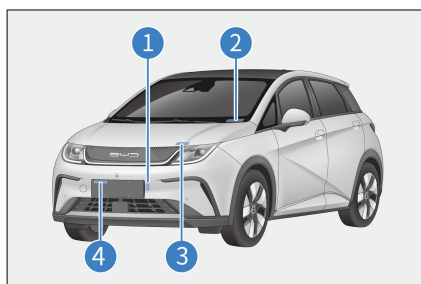

- ⑤ Attached on the middle sheet metal surface above the tailgate glass
- ⑥ Attached on the sheet metal surface of the left rear wheel envelope
- ⑦ Attached on the sheet metal surface inside the left rear door sill
- ⑧ Attached on the sheet metal surface at the lower left corner of the front left door

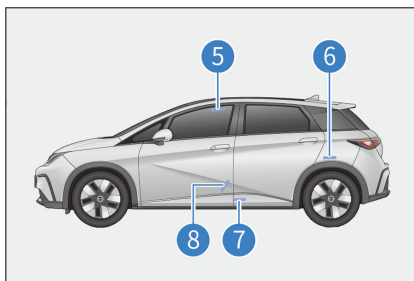

Position of engraved VIN:

VIN is engraved on the lower beam of the driver seat. After connecting the VDS, the Vehicle Identification Number (VIN) can be found in the upper right corner of the screen for the corresponding model. For details, please refer to the VDS operation manual.

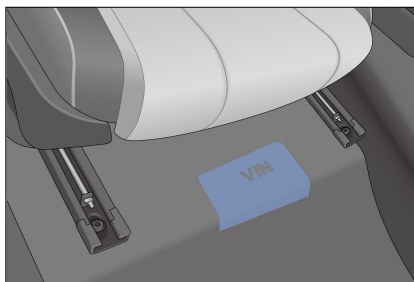

Vehicle Nameplate

The vehicle nameplate is attached on the lower part of the right B-pillar.

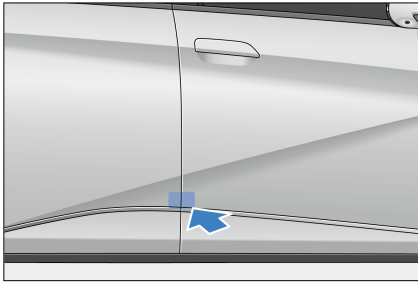

Model and Serial Number of Drive Motor

- ① Engraved on the underside of drive motor housing.

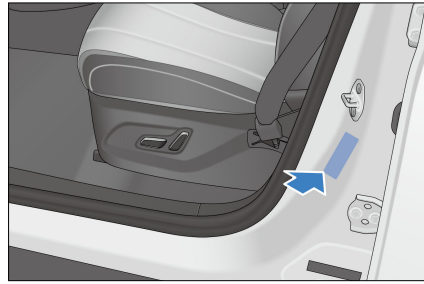
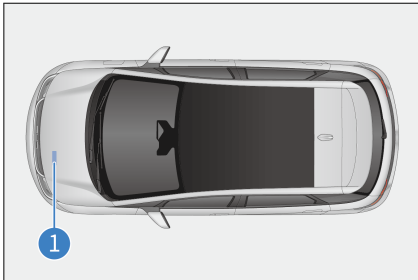

The airbag warning label is printed on the front passenger's sun visor.

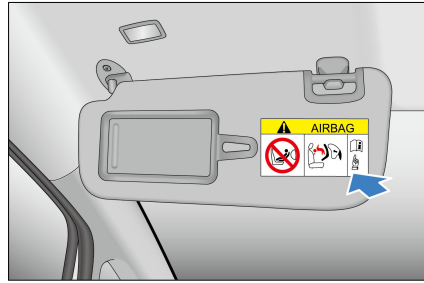

The tyre pressure label is attached below the left B-pillar lock ring.

Warning Labels

- ① A/C system and cooling fan label
- ② Battery position label

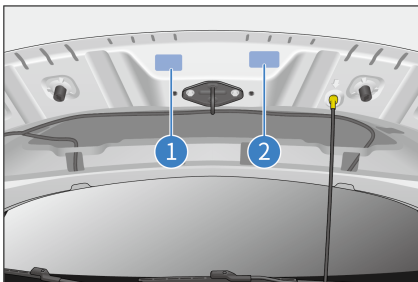

Side airbag warning labels are attached below the left and right B-pillar lock rings.



The label showing charging connector removal precautions is attached to the inner surface of the charge port door.

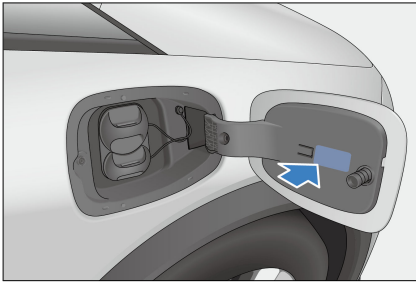

⚠ CAUTION

- Do not overlap the sticker transponder with the glass frame or other objects.

The child protection lock label is engraved on the metal sheet surface on the left and right rear doors.



Transponder Mounting Position

The transponder mounting position is located in the upper left of the front windscreen.



Declarations of Conformity

Smart Key Certification



Uzbekistan
Model: D0-92



EU countries
Model: D0-92



Brazil
Model: D0-92
This equipment is not entitled to protection against harmful interference and may not cause interference to duly authorised systems.

FCC ID: 2A5DH-DAEA-92

The United States
Model: D0-315



Japan
Model: D0-315



South Korea
Model: D0-92/D0-62

Radio Frequency Identification



Your vehicle has different types of radio equipment. The manufacturers of the radio equipment declare the RF Modules listed above have been evaluated against the essential requirements and other relevant provisions of Directive 2014/53/EU. The full

text of the EU declaration of conformity is available at the following Internet address: <https://cn-prod.byd.com/eu/eu-doc>.

Name of Components and Parts	Discharging frequency	Maximum discharging power
interior detection antenna assembly	125KHz	0.0129mW@1m
Smart Key	434MHz	0.000002mW@1m
Left body control module	434MHz	/
Tire pressure sensor	433.62MHZ	3.8*E-5mW@1m
Tire pressure monitoring module	433.62MHZ	/
Wireless charger module	127±30KHz	/
CDP radar	60GHZ	2.5W
Accessing without the smart key (NFC)	13.56MHZ	2.5W
DAB radio	174 - 240MHz	/
Infotainment system CPU	GSM900 : 880 - 915MHz	33dBm(Conducted)
	DCS1800 : 1710 - 1785MHz	30.38dBm(Conducted)
	WCDMA Band1 : 1920 - 1980MHz	24.7dBm(Conducted)
	WCDMA Band8 : 880 - 915MHz	24.78dBm(Conducted)
	FDD LTE Band1 : 1920 - 1980MHz	22.83dBm(Conducted)
	FDD LTE Band3 : 1710 - 1785MHz	23.51dBm(Conducted)
	FDD LTE Band7 : 2500 - 2570MHz	23.99dBm(Conducted)
	FDD LTE Band8 : 880 - 915MHz	23.21dBm(Conducted)
	FDD LTE Band20 : 832 - 862MHz	23.21dBm(Conducted)

Name of Components and Parts	Discharging frequency	Maximum discharging power
	FDD LTE Band28 : 703 - 803MHz	23.6dBm(Conducted)
	FDD LTE Band38 : 2570 - 2620MHz	23.69dBm(Conducted)
	FDD LTE Band40 : 2300 - 2400MHz	24.87dBm(Conducted)
	Bluetooth : 2402 - 2480MHz	10dBm(EIRP)
	E-GSM900/GPRS 900/EGPRS900UL/DL : 880/925MHz - 915/960MHz	2.0417W(conducted)
	GSM1800/GPRS 1800/EGPRS1800UL/DL : 1710/1805MHz - 1785/1880MHz	1.1885W(conducted)
	UTRA band 1 UL/DL : 1920/2110MHz - 1980/2170MHz	0.2773W(conducted)
	UTRA Band 8 UL/DL : 880/925MHz - 915/960MHz	0.2965W(conducted)
	LTE Band 1 UL/DL : 1920/2110MHz - 1980/2170MHz	0.2547W(conducted)
Ecall	LTE Band 3 UL/DL : 1710/1805MHz - 1785/1880MHz	0.2624W(conducted)
	LTE Band 7 UL/DL : 2500/2620MHz - 2570/2690MHz	0.2183W(conducted)
	LTE Band 8 UL/DL : 880/925MHz - 915/960MHz	0.2636W(conducted)
	LTE Band 20 UL/DL : 832/791MHz - 2620/2620MHz	0.2399W(conducted)
	LTE Band 38 UL/DL : 2570/2570MHz - 2620/2620MHz	0.2239W(conducted)
	LTE Band 40 UL/DL : 2300/2300MHz - 2400/2400MHz	0.1954W(conducted)
MmWave Radars	76-79GHz	79GHz
Front MmWave Radars	76-79GHz	79GHz

Numerics

12V Auxiliary Power..... 151

A

A/C Buttons..... 142
A/C Control Panel, Car Speakers,
Dashboard, Control Panel and
Switches..... 162
A/C Function Definitions..... 143
A/C Operation Interface..... 143
A/C System Maintenance..... 167
A/C Vents..... 146
About BYD App..... 146
Access..... 49
Account Registration..... 146
Acoustic Vehicle Alerting System
(AVAS)..... 125
Adaptive Cruise Control (ACC)..... 104
Adjusting Front Seats..... 52
Adjusting Headlight Height..... 60
Adjusting the Rearview Mirror
Manually..... 135
Adjusting the Steering Wheel
Manually..... 57
Airbag Triggering Conditions and
Precautions..... 17
Airbags..... 15
Anti-lock Braking System (ABS)... 133
Anti-theft Alarm System* 26
Anti-theft Indicator* 26
Automatic EPB Release upon Vehicle
Start..... 100
Automatic Vehicle Washing..... 161
AVH Switch..... 101

B

Battery Leakage Rescue..... 175
Battery Properties..... 86
Battery Usage Tips..... 87
Bill Box..... 147
Blind Spot Assist (BSA)..... 120
Brake Fluid..... 167

Break-in Period..... 90
BYD Assistant..... 141

C

Canopy Maintenance* 164
Cargo Cover..... 153
Carpet..... 161
Carrying Items in the Passenger Area
..... 93
Carrying Luggage..... 93
Central Locking..... 64
Centre Console Storage
Compartment..... 148
Charge Port Anti-theft Lock..... 84
Charging..... 76
Charging Precautions..... 73
Charging Safety Warnings..... 72
Child Presence Detection (CPD)... 123
Child Protection Lock..... 51
Child Restraint Systems..... 21
Closing the Bonnet..... 166
Coolant..... 166

D

Dashboard Central Storage
Compartment..... 148
Data Collection and Processing..... 27
Declarations of Conformity..... 190
Direct Tyre Pressure Monitoring.. 124
Discharging Device* 84
Disclosure of Personal Data to
Authorities..... 29
Door Bins..... 147
Doors and Windows..... 161
Driver Assistance Mode Switches... 64
Driver Attention Warning (DAW)... 122
Driving Instructions..... 102
Driving Safety Systems..... 131

E

Electronic Smart Key..... 42

Emergency Boot Releasing from the Inside.....	48
Emergency Braking When Brake Pedal Fails.....	100
Emergency Call (E-Call).....	66
Emergency Lane Keeping Assist (ELKA).....	119
Emergency Locking Retractor Function.....	12
Emergency Shutdown System....	174
Emergency Unlocking of the Charge Port.....	84
Emergency Vehicle Locking with Mechanical Key.....	49
Engaging EPB Automatically.....	99
Engaging EPB Manually.....	99
EPB Operating Sound.....	101
EPB Switch.....	99
EPB System Indicator.....	101
Exterior Cleaning.....	160
External Discharging Method.....	85

F

Fire Prevention.....	94
Folding Rear Seats.....	53
Front Cross Traffic Alert (FCTA) & Front Cross Traffic Braking (FCTB)....	113
Front Seat Cup Holder.....	149
Fuses.....	171

G

Gear Shift Controls.....	98
General Charging Troubleshooting	75
Gestures and Responses.....	141
Glasses Case*.....	149
Glove Box.....	148
Grab Handles.....	150

H

Hazard Warning Light Switch.....	67
----------------------------------	----

High-Voltage Battery.....	86
Hook.....	153

I

If a Tyre Goes Flat.....	177
If EPB Release Fails.....	100
If Smart Key Battery Is Exhausted	174
If the Vehicle Needs Towing.....	176
Indicators and Warning Lights.....	33
Individual Centre and Vehicle Management.....	147
Infotainment Touchscreen.....	140
Initialisation.....	68
Installing Child Restraint Systems.	23
Intelligent Charging.....	81
Intelligent Cruise Control (ICC)....	108
Intelligent High Beam Control (IHBC) 116
Intelligent Power Braking System	131
Intelligent Speed Limit Control (ISLC) 115
Interior Cleaning.....	161
Interior Light Switch.....	68

K

Keeping the Vehicle Safe for Driving 91
--------------------------------------	----------

L

Lane Departure Assist (LDA).....	117
LCD Instrument Cluster.....	32
Leather.....	162
Light Switches.....	58
Loading the Boot.....	93
Locking/Unlocking with Central Locking.....	49
Locking/Unlocking with Mechanical Key.....	46
Locking/Unlocking with NFC Key Card.....	48

Locking/Unlocking/Finding the Vehicle with Smart Key.....	46
Low-Voltage Battery.....	88

M

Maintenance Plan.....	156
Maintenance Schedule Requirements	156
Manual Anti-glare Function.....	135
Manual Vehicle Washing.....	160
Mechanical Key.....	43

N

No Drunk Driving.....	91
No Speeding.....	91

O

Odometer Switch.....	64
Opening the Hood.....	165
Opening with Interior Door Handle	46
OTA Update.....	141
Other Instrument Cluster Fault Prompts.....	39

P

Paint Maintenance Tips.....	159
Panoramic View System.....	126
Parking Assist System.....	127
Passenger's Window Switches.....	64
Permanent Vehicle Transfer to Third Parties and Offline Mode.....	29
Power Window Switches*.....	62
Predictive Emergency Braking (PEB) System.....	110
Preparations Before Driving.....	98
Pretensioner and Force Limiter Function.....	12

R

Rear Seat Cup Holder.....	149
Rear Seat Head Supports.....	53
Recycling the High-voltage Battery	88
Reflective Vest.....	174
Releasing EPB Manually.....	99
Remote Start*	97
Replacing Wiper Blades.....	136

S

Safety Check Before Driving.....	97
SD Card Slot*	151
Seat Belt Cleaning.....	161
Seat Belt Overview.....	12
Seat Belt Reminders.....	14
Seat Precautions.....	51
Seatback Pockets.....	149
Self-Maintenance.....	163
Sensor Type.....	128
Side Curtain Airbags.....	17
Side Mirror Adjustment.....	136
Smart Charging.....	81
Snow Chains.....	137
Start-up.....	49
Starting Inside the Vehicle.....	96
Steering Wheel Switches.....	55
Suggestions for Vehicle Use.....	92
Sun Visor and Vanity Mirror.....	149
Sunshade Switch*	68

T

Tow Eye.....	177
Traffic Sign Recognition (TSR).....	114
Trailer Towing.....	91
Transponder Mounting Position..	189
Tyres.....	169

U

Unlocking the Boot with Microswitch	48
USB Ports.....	150
Using AC Charging Piles.....	79
Using DC Charging Piles.....	80
Using Mode 2 Charging Cable*	76
Using Seat Belts.....	12
Using Tyre Repair Kit.....	179

V

Vehicle Corrosion Prevention.....	159
Vehicle Data Processing.....	27
Vehicle Fire Rescue.....	175
Vehicle Identification Number (VIN)	187
Vehicle Nameplate.....	187
Vehicle Servicing.....	158
Vehicle Storage Precautions.....	165

W

Wading into Water.....	93
Warning Labels.....	188
Washer.....	167
Window Lock Switch.....	63
Winter Driving Precautions.....	103
Wiper Blades.....	168
Wiper Switches.....	61
Wireless Phone Charger*	151

Y

Your Data Protection Rights.....	29
----------------------------------	----

Abbreviations

Abbreviations

Terminology	Full Name	Terminology	Full Name
ECU	Electronic Control Unit	EDR	Event Data Recorder
NFC	Near Field Communication	ACC	Adaptive Cruise Control
ECO	Ecology, Conservation, Optimisation	NORMAL	Normal
SPORT	Sport	SOC	State of Charge
EPB	Electronic Parking Brake	AVH	Auto Vehicle Hold
FCW	Forward Collision Warning	AEB	Automatic Emergency Braking
TSR	Traffic Sign Recognition	ISLC	Intelligent Speed Limit Control
IHBC	Intelligent High Beam Control	LDA	Lane Departure Assist
LDW	Lane Departure Warning	LDP	Lane Departure Prevention
ELKA	Emergent Lane Keeping Assist	BSA	Blind Spot Assist
BSD	Blind Spot Detection	RCTA	Rear Collision Traffic Alert
RCTB	Rear Cross Traffic Braking	RCW	Rear Collision Warning
DOW	Door Open Warning	AVAS	Acoustic Vehicle Alerting System
VDC	Vehicle Dynamics Control	TCS	Traction Control System
HHC	Hill Hold Control	HBA	Hydraulic Brake Assist
CDP	Controlled Deceleration for Parking Brake	ESC	Electronic Stability Controller
CST	Comfort Parking	ABS	Anti-lock Braking System
EBD	Electronic Brakeforce Distribution	MAX	Maximum
MIN	Minimum	VIN	Vehicle Identification Number

BUILD YOUR DREAMS

Edition date: 05.2025 EN_V3 (Right-hand Drive)